

30TH
ANNIVERSARY
CELEBRATION

Whole Earth
Winter 1998

WHOLE EARTH CATALOG

The
Complete
1968
Whole Earth
Catalog

access to tools

New writing by

STEWART BRAND
WALTER MOSLEY
JANE JACOBS
ANDREW WEIL, MD
JARON LANIER
LYNN MARGULIS
GARY SNYDER
ORVILLE SCHELL
MISS MANNERS
BRIAN ENO
KEVIN KELLY
DONELLA MEADOWS
PETER COYOTE
WES JACKSON
TERRY TEMPEST WILLIAMS
VINE DELORIA, JR.
RICK FIELDS
MARY CATHERINE BATESON
AMORY B. LOVINS
WENDELL BERRY
ANNE WALDMAN

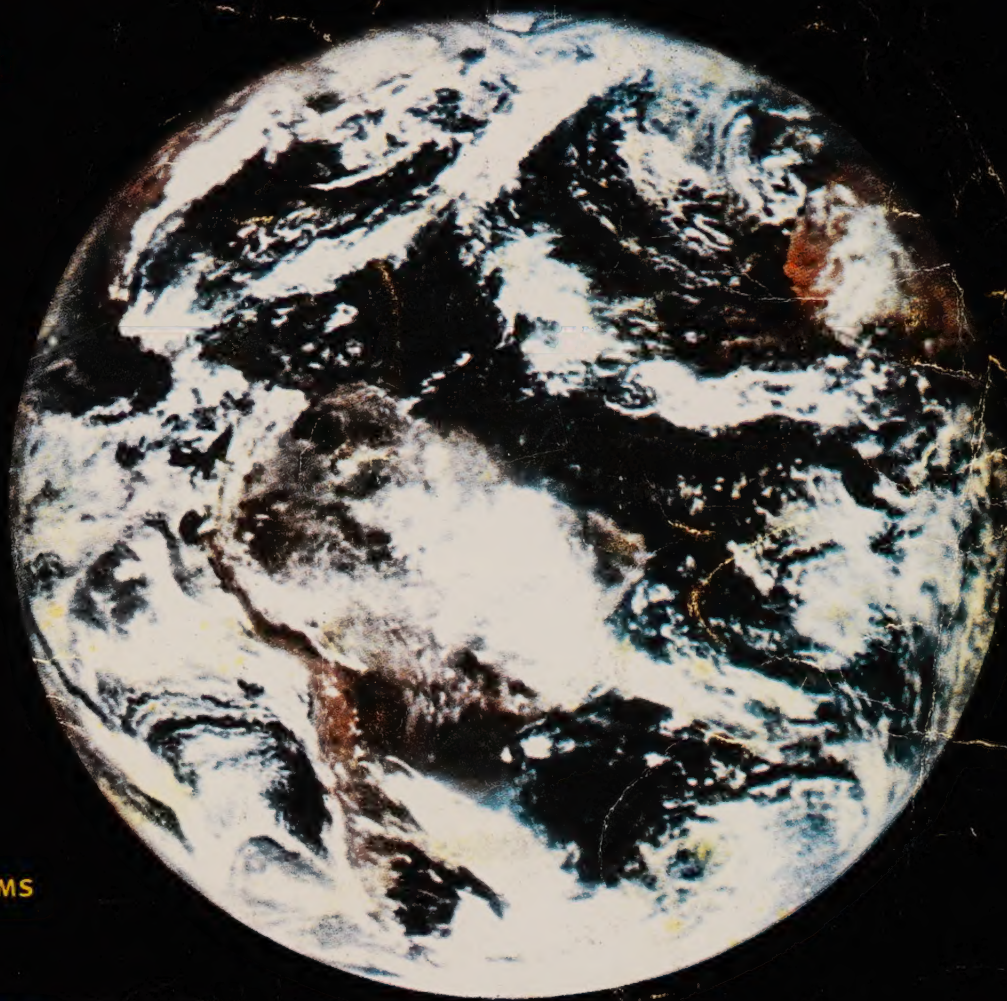

Fall 1968

\$8.00/\$9.50 CAN



DO GOOD.
TRY STUFF.
FOLLOW THRU.

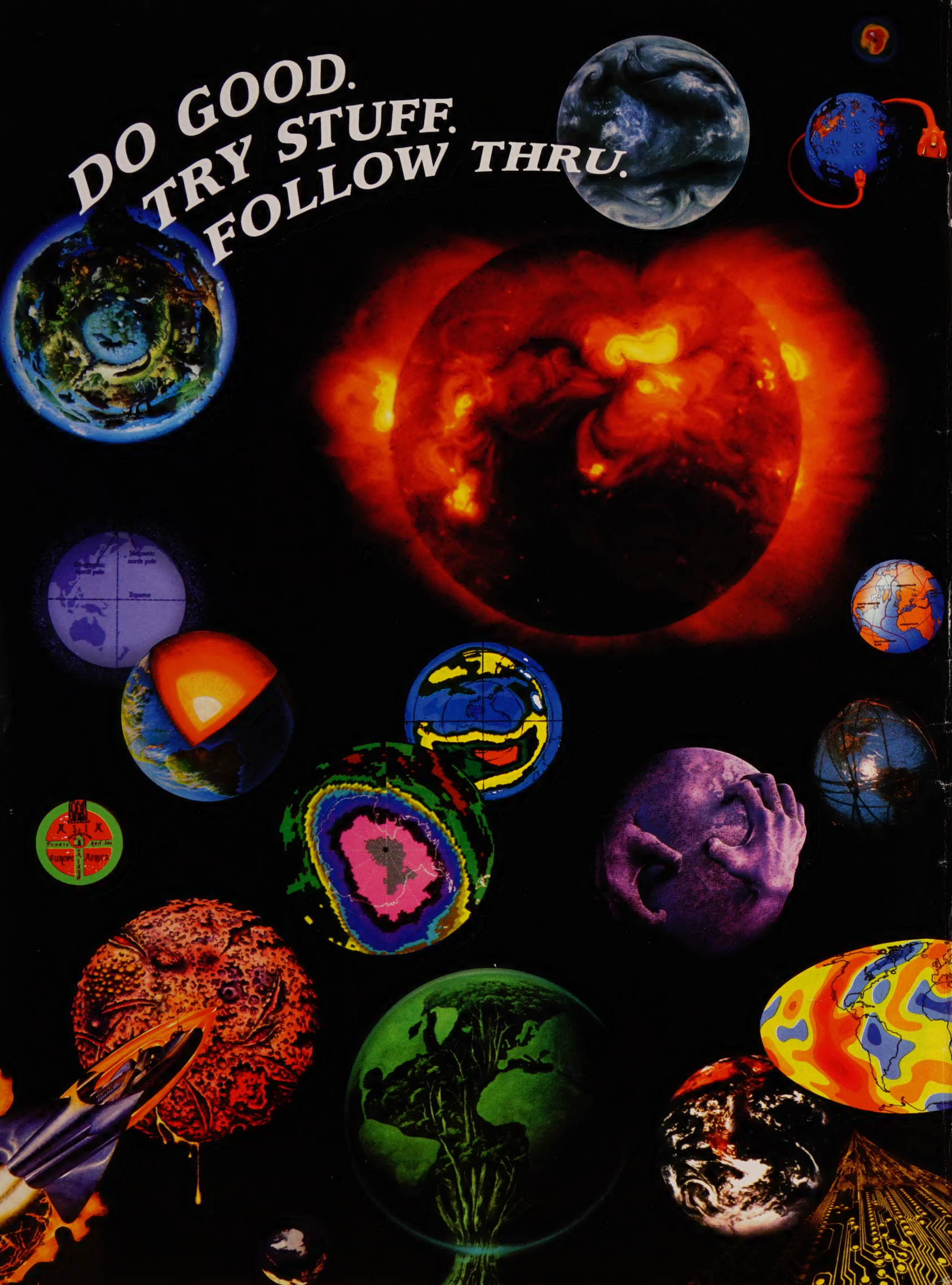

PROLOG: ANNIVERSARIES TO COME

by PETER WARSHALL

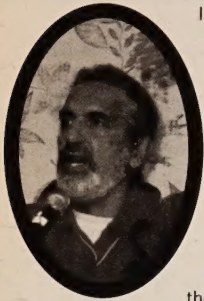

I sit at my editor's window watching deer eating fallen rosehips on the disabled-access ramp to our office. Last night, a homeless woman told Board member Diana Hadley about poachers who were roaming Falkirk Park and smothering deer with plastic bags. I keep track of the small herd and only the bucks may be gone. In this urban fringe, they could have wandered anywhere.

But, to Sonya, being homeless and a bit possessed, poaching is a gut metaphor: the world holds ominous disharmonies. Obtaining food is dangerous. She might become dangerous. Events are veering out of control.

In 1968, a similar gut feeling—the world is one holy mess—rumbled in neighborhoods. Institutions—from family to business to government—seemed out-of-date, ignorant, muddling along, responding without skill, spewing anger. Czech students firebombed Soviet tanks. Mexican *federales*, French gendarmes, and German *politzei* killed their nations' students. The Tet offensive media coverage (or lack of coverage) challenged the veracity of the American government and media. Nixon became President after riots at the Chicago Democratic Convention. The assassinations of Martin Luther King and Robert Kennedy stunned. With so much death so close to home, taken-for-granted assumptions about how our nation-state operates, organizes itself, and lives with diversity had to be re-thought. How edited are information flows? Just what is democracy? What we knew and what we had learned did not seem very useful.

In this same year, Stewart Brand and a small group of cohorts published the first Whole Earth Catalog. In retrospect, Whole Earth was not the only small group dreaming up new media. *Sesame Street* and *Sixty Minutes* also started in 1968. And, at the Stanford Research Institute, Doug Engelbart and his friends assembled the first mouse and computer interface, the embryo of the Web.

What was unique to the Catalog was how it fed a deep hunger in America—a hunger to know new stuff not taught in schools. The Catalog loaded up on interesting info and, contrary to the possessive attitudes of academia, offered to share as much information and knowledge as it could, and welcomed any person to send in more. Later, Stewart would coin the phrase: "Information wants to be free." To be interesting, a tool or book had to answer two simple questions: Was it the best around? Was it useful to living? Compared to standard practices among existing publications, to review only excellent stuff, and let the poor stuff die its own death, was radical.

Readers have told and retold their first encounters with the Catalog. Most readers still assume that the first Catalog they discovered was the first edition and they still have it. But, usually it's a second or tenth edition. We've only been able to find two copies of the 1968 edition: one owned by J. Baldwin and the other by Lloyd Kahn. That's a major reason why we've reprinted the real first edition here. The impact of first encounter (in memory, at least) was a sigh of relief. Learning is not for grades. Mistakes are a fine part of learning. The doctor doesn't always have to be the authority. You can help yourself heal. Sometimes it's best to think not what your philosophy is, but how what you think or feel fits into a bigger, more voluminous system: a shelter in its environment, an ecology of mind, a new techno-tool in a

nation's economy. Through the Catalog, livelihood became clearly differentiated from career; money turned into a tool, not an end in itself. It's hard to conjure up how foreign these simple thoughts appeared in 1968.

Whole Earth refused to become one more pedantic lecturer or one more ideologue for the single path. In the fruitful tradition of American magazines that had been forums for the debates over slavery or women's votes, Whole Earth presented a contest of ideas. Equal page space to those for or against space colonies; sex lite or sex bold; the metric or English system; the empowering or disempowering impacts of TV and computers; global or local printing of money; Aldo Leopold and Herman Kahn. By allowing for openness, Stewart and the staff created a sense of belonging for readers (who were also participants) in "unedited" conversations found nowhere else.

Readers couldn't quite figure the first edition out. On the cover, our planet floated on an unreal homogeneous black background. Inside, is this a *Farmer's Almanac*? An *LL Bean Catalog*? Not since the Jeffersonian period had any catalog published a mix of knowledge from both rural and urban settlements. In the next few editions, it added wilderness. Rural know-how (how to do stuff) collaged with adventurous intellect.

Other media reported the news. Whole Earth scouted the fringes and reported mindful and manual experiments, books, and tools that might alter future large-scale history. The Gaia hypothesis, voluntary simplicity, virtual communities, negawatts, watershed restoration, hacking computer codes, etc. etc. People, anywhere, trying stuff out. Some believed we were prophets.

But, the first Catalog shunned the business of prophecy. In 1968, gay/lesbian acceptance, single-parent families, industrial poisons, global teenagers, holistic health, nanotechnology, soybean products as an alternative to meat, biotechnology, bioregions, and cultural survival had not yet registered clearly even on Whole Earth's antennas. The Catalog had to wait to become an active, participatory network with passionate outside contributors before these livelihoods and technologies could saunter front and center.

To celebrate, we have combined the first Catalog with the winter issue of Whole Earth (the magazine some still call CoEvolution Quarterly). Here are about forty short essays by friends. It's a continuation of the old theme: what's a difference that might most make a difference, a difference close to your heart or mind?

Today, our readership contemplates a boastful techno-economic system which appears to ignore thermodynamics, if not the entire configuration of the planet's intricate webbing. Once again, students, governments, workers, and citizens wonder if they could be hit by a drunken world spinning out-of-control. And Whole Earth's talents still seem robust and resilient (to use the new lingo of ecology) in navigating through contemporary history. Experimental and fun; a scout for depth and fringes; intimate and pragmatic; soulful but not sentimental; a sleuth of intelligent crafting; open to new voices; and, thank you, a community of goodwill.

Peter Marshall
Current editor



What a compliment is mimicry! What a compliment the specialized "niche" publications that carved out a piece of Whole Earth and turned it into their own. What a compliment to see magazines delighting in multimedia (salons, conferences, festivals, roadshows, websites) initiated "long ago" by Whole Earth compatriots. The genealogy is too extensive. Pick up almost any catalog or magazine and the connections should be clear.

CONTENTS OVERVIEW

WE ARE AS GODS BY STEWART BRAND . . .NEXT PAGE

1968 WHOLE EARTH CATALOG
TABLE OF CONTENTSIN TWO PAGES

1998 WINTER WHOLE EARTH
TABLE OF CONTENTSAFTER PAGE 62

INSIDE COVER: IMAGES OF THE EARTH. CENTER: SUN X-RAYED (ISAS/NASA). UPPER RIGHT: ATMOSPHERIC MOISTURE CONTENT OVER ATLANTIC (ESA). PLUGGED EARTH © MICHAEL AGLILOLO PHOTO NETWORK. MIDDLE: MAGNETIC FIELD. EARTH'S INTERIOR. MEDIEVAL EARTH MAP. CZONE HOLES ABOVE ANTARCTICA (NASA). TECTONIC PLATES. LOWER: R. CRUMB'S EARTH (WER NO. 79). NITRIC ACID IN ATMOSPHERE (NOAA). CHIP WITH EARTH © RON BROWN PHOTOGRAPHS. HEAT FLOW ON EARTH'S SURFACE.

COVER: Whole Earth Magazine began as the Whole Earth Catalog. In celebration of our thirtieth anniversary, we are displaying the original name and artwork from the inaugural 1968 issue of the publication on the cover.

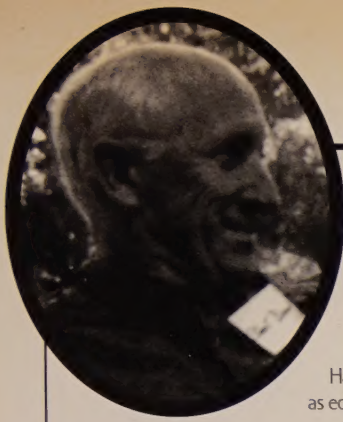

WE ARE AS GODS

by STEWART BRAND, FOUNDER

Thirty years ago, Stewart and a handful of helpers compiled the first Whole Earth Catalog. Stewart tells the story of the 1968 Catalog and other early history on our web site (www.wholeearthmag.com) and on page 439 of the Last Whole Earth Catalog. After a few years, Stewart kept trying to let the Catalog die in order not to perpetuate an idea beyond its authentic vivid liveliness. But it wouldn't stay down—Last Whole Earth Catalogs and Whole Earth Epilogs and other permutations bobbed back up. The Last Whole Earth Catalog was awarded the National Book Award (1972). Stewart started the CoEvolution Quarterly as a supplement to the Catalog, originally with articles from the technical literature that he felt should have wider circulation. The Gaia Hypothesis was one such (see winter, 1998 issue, p. 4). Stewart co-founded the computer conferencing system known as the WELL and the annual Hacker's Conference. CoEv evolved into the Whole Earth Review when it combined with the short-lived Whole Earth Software Review. Even after Stewart left as editor (1985), his publication patterning and attitudes (e.g., only review good stuff, let the bad fade) guided the Catalogs and magazine.

Though readers steadfastly refuse to allow Stewart his independence after seventeen years of editing Whole Earth (I'm always asked: "Is Stewart still editor?"), he has been thoroughly independent, writing *The Media Lab: Inventing the Future at MIT* (1987) and his well-regarded book, *How Buildings Learn* (1994). He also co-founded and is managing director of the Global Business Network, a consulting firm specializing in scenarios for the future. That doesn't mean that he isn't "family" or part of that indefinable presence called the Whole Earth community. Many of GBN's Network members overlap with Whole Earth writers/contributors. Stewart kindly showed up at the Marin Community Foundation to help us say: thirty years in Marin County is enough to be considered part of local cultural heritage and worthy of local philanthropic support. He's enthusiastic about getting Whole Earth's library out of containers and available to the public. He allows us to pirate book choices from his GBN selections.

Stewart has just finished a new book on time and is co-founder of the Long Now Project to make a 10,000 year clock (winter issue, p. 3). He's refurbished *Mirene*, his Columbia River tugboat, so that it can cruise the Bay, and he keeps in shape with a veteran's group that treks and exercises near Mt. Tamalpais. He's definitely been my educational mentor, asking, like all great teachers, specific and directed questions that need attention but seem buried in the subconscious—until asked. While my talents reside in scouting nature, Stewart's genius is as a great scout of culture and history. His keen senses hunt down the most interesting experiments, ideas (and their spokespeople) and celebrations. I always check out the tools on his belt and his current mind-tools for building robust and resilient deeper structures. Along the way, his tool kits have changed America in ways from which it cannot go back. —Peter Warshall

As unexpected and ungrammatical as a clap of thunder on a sunny day was the opening line of that first Whole Earth Catalog in 1968:

"We are as gods and might as well get good at it."

Credit where it's due: I stole the line. Page one, chapter one of *A Runaway World?* by British anthropologist Edmund Leach (Oxford, 1968) begins:

Men have become like gods. Isn't it about time that we understood our divinity? Science offers us total mastery over our environment and over our destiny, yet instead of rejoicing we feel deeply afraid. Why should this be? How might these fears be resolved?

Leach's book was based on his 1967 Reith Lectures broadcast on the BBC. With their bold optimism, the lectures were highly popular and also ferociously criticized in academe and the press. Alistair Cooke predicted in the *Chicago Sun-Times*, "Leach has suddenly come roaring up in England and no doubt will soon explode here, as middle-aged hero of the rebel young." So far as I know, I was the only rebel youngster (then age 30) to respond, but my rebroadcast of Leach's line did have a certain explosive effect. The Whole Earth Catalog also borrowed some of Leach's attitude, evident in paragraphs of his such as:

By participating in history instead of standing by to watch we shall at least be able to enjoy the present. The cult of scientific detachment and the orderly fragmented way of living that goes with it, serve only to isolate the human individual from his environment and from his neighbors—they reduce him to a lonely, impotent and terrified observer of a runaway world. A more positive attitude to change will not mean that you will always feel secure, it will just give you a sense of purpose. You should read your Homer. Gods who manipulate the course of destiny are no more likely to achieve their private ambitions than are men who suffer the slings and arrows of outrageous fortune; but gods have much more fun!

Where the Whole Earth Catalog diverged from Leach's admirable program was in an area which

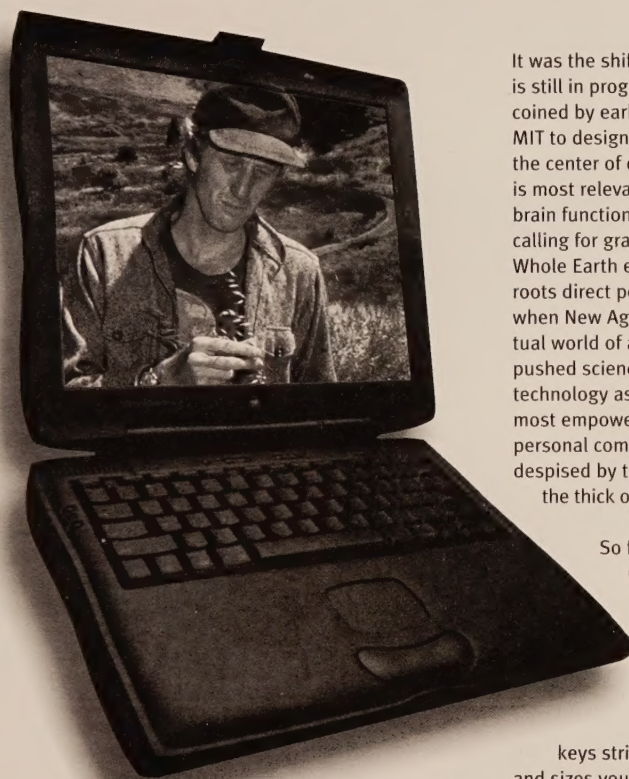

Student Stewart Brand (1960s) scopes out a California grass.

still distinguishes America from England and Europe. Leach wrote, "We simply must take charge of our own fate. We must somehow see to it that the decisions which have long-term consequences are taken by men who understand what they are doing and not by bewildered amateurs." By contrast, the rest of Whole Earth's purpose statement went: "So far, remotely done power and glory—as via government, big business, formal education, church—has succeeded to the point where gross defects obscure actual gains. In response to this dilemma and to these gains a realm of intimate, personal power is developing—power of the individual to conduct his own education, find his own inspiration, shape his own environment, and share his adventure with whoever is interested."

In other words, Whole Earth embraced the amateurs rather than deplored them. We rewrote Leach's line to: "We must somehow see to it that the decisions which have long-term consequences are taken by amateurs who understand what they are doing."

It was the shift from hierarchy to heterarchy, which is still in progress worldwide. ("Heterarchy" was coined by early cybernetician Warren McCulloch at MIT to designate networked structures in which the center of control constantly moves to wherever is most relevant and useful; he was thinking of brain function.) At a time when the New Left was calling for grass-roots political (i.e. referred) power, Whole Earth eschewed politics and pushed grass-roots direct power—tools and skills. At a time when New Age hippies were deploring the intellectual world of arid abstractions, Whole Earth pushed science, intellectual endeavor, and new technology as well as old. As a result, when the most empowering tool of the century came along—personal computers (resisted by the New Left and despised by the New Age)—Whole Earth was in the thick of the development from the beginning.

So far as I can tell, the 1968 Whole Earth Catalog was the first example of desktop publishing. The breakthrough tool was the IBM Selectric Composer—a fancy electric typewriter with a replaceable

"golf ball" instead of individual keys striking the paper. The many type fonts and sizes you see in this replica of the '68 Catalog are how many "golf balls" we had. Typesetting was instant and cheap. The other revolutionary tool was a Polaroid MP-3 camera, which allowed us to copy line shots directly from books and to make halftones which could be pasted right onto the layout sheets. Handling graphics was instant and cheap.

We were as publishers and tried to get good at it. ∞

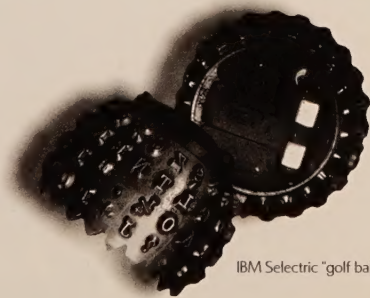

IBM Selectric "golf balls."

WHOLE EARTH CATALOG 1968

Understanding Whole Systems

Buckminster Fuller
Cosmic View
Full Earth
Earth Photographs
The World From Above
Surface Anatomy
Geology Illustrated
Sensitive Chaos
A Year From Monday

General Systems Yearbook
Synthesis of Form
On Growth and Form
Tantra Art
Psychological Reflections
The Human Use of Human Beings
The Ghost in the Machine
The Year 2000
The Futurist

Shelter and Land Use

The Dymaxion World of Buckminster Fuller
Space Structures
Tensile Structures, Volume One
Dome Cookbook
Good News
Architectural Design
The Japanese House
Audel Guides
Alaskan Mill

Village Technology
The Indian Tipi
Tipis
Aladdin Kerosene Lamps
Man's Role in Changing the Face of the Earth
Two Mushroom Books
Organic Gardening
ABC and XYZ of Bee Culture
Universal Mill

Industry and Craft

The Way Things Work
Introduction to Engineering Design
The Measure of Man
Thomas Register of American Manufacturers
New Scientist
Scientific American
Industrial Design
Product Engineering
Clearinghouse

Science and Civilization in China, Volume IV,
Part 2
Silvo Catalog
Brookstone Tools
Jensen Tools
Miners Catalog
Blasters' Handbook
Direct Use of the Sun's Energy
Structure, Form and Movement

Van Waters & Rogers
Bookmaking
Zone System Manual
A Sculptor's Manual
Creative Glass Blowing
Buckskin
Cut Beads
Melrose Yarns

Communications

Human Biocomputer
The Mind of the Dolphin
Information
9100A Computer
Cybernetics
Eye and Brain
Design for a Brain

Education Automation
Intelligent Life in the Universe
The McGraw-Hill Encyclopedia of Space
Lafayette and Allied Catalogs
Heathkit
Modern Business Forms
American Cinematographer

American Cinematographer Manual
The Technique of Documentary Film Production
The Technique of Television of Production
Auto Repair Manual
Books
Subject Guide to Books in Print
Art Prints

Community

The Modern Utopian
The Realist
Green Revolution
Kibbutz: Venture in Utopia
Dune
Groups Under Stress

The Merck Manual
Land for Sale
Consumer Reports
Government Publications
The Armchair Shopper's Guide
How to Get 20% to 90% off on Everything You Buy

Nomadics

Innovator
The Retreater's Bibliography
The Book of Survival
The Survival Book
Survival Arts of the Primitive Paiutes
Camping and Woodcraft
Light Weight Camping Equipment and How to Make It
Backpacking
L.L. Bean

Recreational Equipment
Gerry Outdoor Equipment
Kaibab Boots
Hot Springs
The Explorers Trademark Log
National Geographic
Sierra Club
The Narrow Road to the Deep North
Trout Fishing In American

Learning

Toward a Theory of Instruction
The Black Box
THIS Magazine is about Schools
Cuisenaire Rods
ITA
LIFE Science Library
Kaiser Aluminum News
700 Science Experiments for Everybody

Edmund Scientific
WFF 'N PROOF
Dr. Nim
We Built Our Own Computers
American Boys Handy Book
Pioneer Posters
Sense Relaxation
Zen Flesh, Zen Bones

Meditation Cushions and Mats
Self Hypnotism
Psycho-Cybernetics
A Yaqui Way of Knowledge
Fundamentals of Yoga
The Act of Creation
The I Ching

WHOLE EARTH CATALOG 1968

PURPOSE

We are as gods and might as well get used to it. So far, remotely done power and glory—as via government, big business, formal education, church—has succeeded to the point where gross obscure actual gains. In response to this dilemma and to these gains a realm of intimate, personal power is developing—power of the individual to conduct his own education, find his own inspiration, shape his own environment, and share his adventure with whoever is interested. Tools that aid this process are sought and promoted by the WHOLE EARTH CATALOG.

FUNCTION

The WHOLE EARTH CATALOG functions as an evaluation and access device. With it, the user should know better what is worth getting and where and how to do the getting.

An item is listed in the CATALOG if it is deemed:

- 1) Useful as a tool,*
- 2) Relevant to independent education,*
- 3) High quality or low cost,*
- 4) Not already common knowledge,*
- 5) Easily available by mail.*

This information is continually revised according to the experience and suggestions of CATALOG users and staff.

USING THE 1968 CATALOG

WARNING: *Using the access information from the 1968 Catalog will drive you nuts. Publishers begged us not to reprint the Catalog with their names anywhere near books they no longer carry. Please don't call a publisher and ask for a book because you saw it here.*



This striped ball appears next to book covers and tools to help you estimate the item's size.

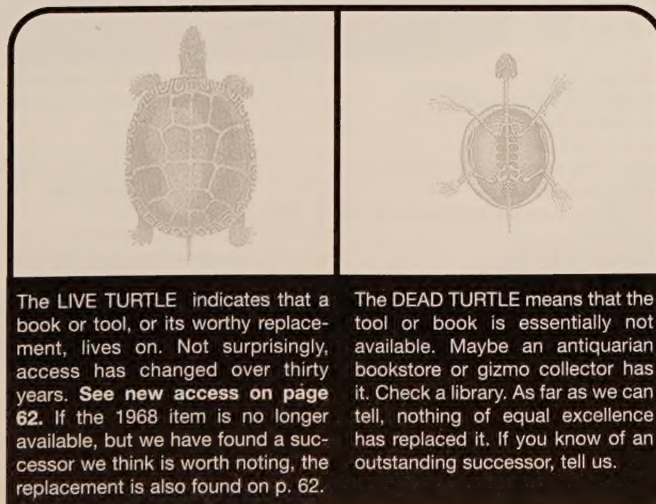

The LIVE TURTLE indicates that a book or tool, or its worthy replacement, lives on. Not surprisingly, access has changed over thirty years. See new access on page 62. If the 1968 item is no longer available, but we have found a successor we think is worth noting, the replacement is also found on p. 62.

The DEAD TURTLE means that the tool or book is essentially not available. Maybe an antiquarian bookstore or gizmo collector has it. Check a library. As far as we can tell, nothing of equal excellence has replaced it. If you know of an outstanding successor, tell us.

Buckminster Fuller

The insights of Buckminster Fuller are what initiated this catalog.

Of the four books reviewed here, *Nine Chains to the Moon* is his earliest and most openly metaphysical, *Ideas and Integrities* his most personal, *No More Secondhand God* the most recent, *World Design Science Decade* the most programmatic.

People who beef about Fuller mainly complain about his repetition – the same ideas again and again, it's embarrassing. It is embarrassing, also illuminating, because the same notions take on different uses when re-approached from different angles or with different contexts. Fuller's lectures have a raga quality of rich nonlinear endless improvisation full of convergent surprises.

Some are put off by his language, which makes demands on your head like suddenly discovering an extra engine in your car – if you don't let it drive you faster, it'll drag you. Fuller won't wait. He spent two years silent after illusory language got him in trouble, and he returned to human communication with a redesigned instrument.

With that, empirical curiosity, and New England perseverance Fuller has forged one of the most original personalities and functional intellects of the age.

I see God in the instruments and the mechanisms that work reliably, more reliably than the limited sensory departments of the human mechanism. And God says observe the paradox of man's creative potentials and his destructive tactics. He could have his new world through sufficient love for "all's fair" in love as well as in war which means you can junk as much rubbish, skip as many stupid agreements by love, spontaneous unselfishness radiant.

The revolution has come – set on fire from the top. Let it burn swiftly. Neither the branches, trunk, nor roots will be endangered. Only last year's leaves and the parasite-bearded moss and orchids will not be there when the next spring brings fresh growth and free standing flowers.

Here is God's purpose – for God, to me, it seems, is a verb, not a noun, proper or improper; is the articulation not the art, objective or subjective; is loving, not the abstraction "love" commanded or entreated; is knowledge dynamic, not legislative code, not proclamation law, not academic dogma, not ecclesiastic canon. Yes, God is a verb, the most active, connoting the vast harmonic reordering of the universe from unleashed chaos of energy. And there is born unheralded a great natural peace, not out of exclusive pseudo-static security but out of including, refining, dynamic balancing. Naught is lost. Only the false and nonexistent are dispelled.

And I've thought through to tomorrow which is also today. The telephone rings and you say to me Hello Buckling this is Christopher; or Daddy it's Allegra; or Mr. Fuller this is the Telephone Company Business Office; and I say you are inaccurate. Because I knew you were going to call and furthermore I recognize that it is God who is "speaking."

And you say aren't you being fantastic? And knowing you I say no.

All organized religions of the past were inherently developed as beliefs and credits in "second hand" information.

Therefore it will be an entirely new era when man finds himself confronted with direct experience with an obviously a priori intellectually anticipatory competence that has interordered all that he is discovering.

[No More Secondhand God]

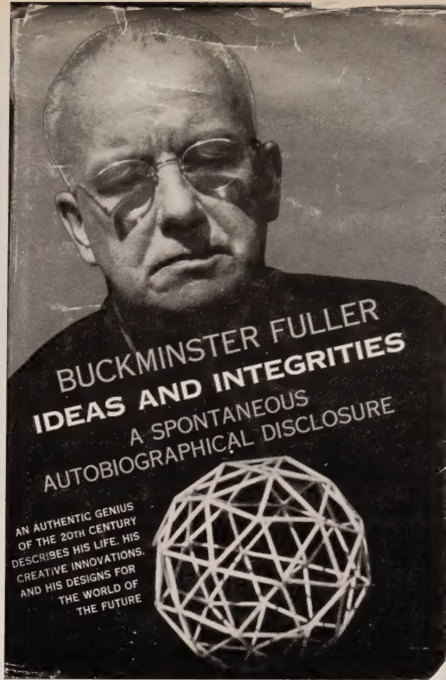

Ideas and Integrities
Buckminster Fuller
1963; 318 pp.

from: Prentice-Hall Inc.
Englewood Cliffs
New Jersey 07631
or WHOLE EARTH CATALOG

\$10.00 postpaid

Standing by the lake on a jump-or-think basis, the very first spontaneous question coming to mind was, "If you put aside everything you've ever been asked to believe and have recourse only to your own experiences do you have any conviction arising from those experiences which either discards or must assume an a priori greater intellect than the intellect of man?" The answer was swift and positive. Experience had clearly demonstrated an a priori anticipatory and only intellectually apprehendable orderliness of interactive principles operating in the universe into which we are born. These principles are discovered but are never invented by man. I said to myself, "I have faith in the integrity of the anticipatory intellectual wisdom which we may call "God." My next question was, "Do I know best or does God know best whether I may be of any value to the integrity of universe?" The answer was, "You don't know and no man knows, but the faith you have just established out of experience imposes recognition of the a priori wisdom of the fact of your being." Apparently addressing myself, I said, "You do not have the right to eliminate yourself, you do not belong to you. You belong to the universe. The significance of you will forever remain obscure to you, but you may assume that you are fulfilling your significance if you apply yourself to converting all your experience to highest advantage of others. You and all men are here for the sake of other men."

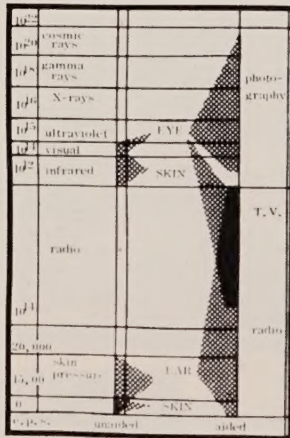

WDS Document 1

World society has throughout its millions of years on earth made its judgements upon visible, tangible, sensorially demonstrable criteria. We may safely say that the world is keeping its eye on the unimportant visible 1 percent of the historical transformation while missing the significance of the 99 percent of overall, unseen changes. Forms are inherently visible and forms no longer can "follow functions" because the significant functions are invisible

There are very few men today who are disciplined to comprehend the totally integrating significance of the 99 percent invisible activity which is coalescing to reshape our future. There are approximately no warnings being given to society regarding the great changes ahead. There is only the ominous general apprehension that man may be about to annihilate himself. To the few who are disciplined to deal with the invisibly integrating trends it is increasingly readable in the trends that man is about to become almost 100 percent successful as an occupant of universe.

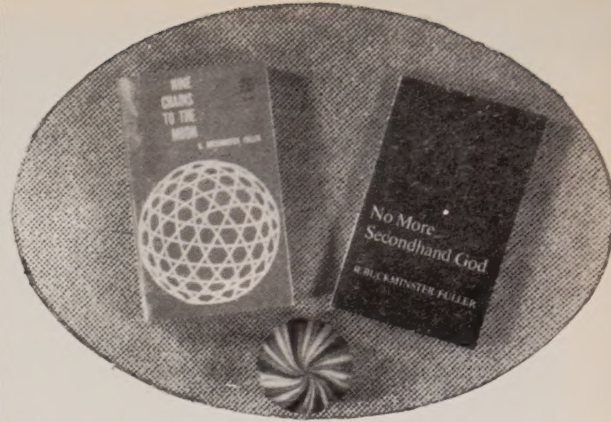

Nine Chains to the Moon
Buckminster Fuller
1938, 1963; 375 pp.

No More Secondhand God
Buckminster Fuller
1963; 163 pp.

\$2.45

\$2.25 postpaid

both from:
Southern Illinois University Press
600 University
Carbondale, Illinois 62903
or WHOLE EARTH CATALOG

Thinking is a putting-aside, rather than a putting-in discipline, e.g., putting aside the tall grasses in order to isolate the trail into informative visibility. Thinking is FM – frequency modulation – for it results in tuning-out of irrelevancies as a result of definitive resolution of the exclusivity turned-in or accepted feed-back messages' pattern differentiability. ["Omnidirectional Halo" No More Secondhand God]

Common to all such "human" mechanisms – and without which they are imbecile contraptions – is their guidance by a phantom captain.

This phantom captain has neither weight nor sensorial tangibility, as has often been scientifically proven by careful weighing operations at the moment of abandonment of the ship by the phantom captain, i.e., at the instant of "death." He may be likened to the variant of polarity dominance in our bipolar electric world which, when balanced and unit, vanishes as abstract unity I or O. With the phantom captain's departure, the mechanism becomes inoperative and very quickly disintegrates into basic chemical elements.

This captain has not only an infinite self-identity characteristic but, also, an infinite understanding. He has furthermore, infinite sympathy with all captains of mechanisms similar to his

An illuminating rationalization indicated that captains – being phantom, abstract, infinite, and bound to other captains by a bond of understanding as proven by their recognition of each other's signals and the meaning thereof by reference to a common direction (toward "perfect") – are not only all related, but are one and the same captain. Mathematically, since characteristics of unity exist, they cannot be non-identical.

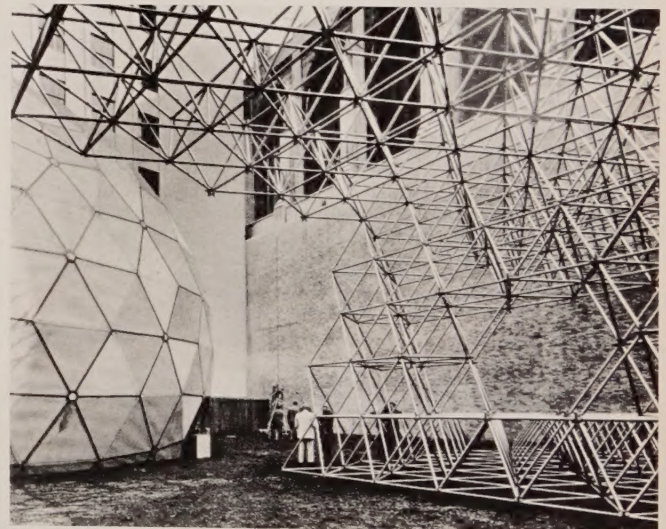

Our Air Force Redomes were installed in the arctic mostly by eskimos and others who had never seen them before. The mass production technology made assembly possible at an average rate of 14 hours each. One of these redomes was loaned by the U.S. Air Force to the Museum of Modern Art in New York City for an exhibition of my work in 1959-1960. It took regular building trades skilled labor one month to assemble the dome in New York City.

WDS Document 2

I define 'synergy' as follows: Synergy is the unique behavior of whole systems, unpredicted by behavior of their respective subsystems' events.

[Ideas and Integrities]

selfishness (self-preoccupation pursued until self loses its way and self generates fear and spontaneous random surging, i.e., panic, the plural of which is mob outburst in unpremeditated wave synchronization of the individually random components).

[No More Secondhand God]

To start off with it is demonstrated in the array of events which we have touched on that we don't have to "earn a living" anymore. The "living" has all been earned for us forever. Industrialization's wealth is cumulative in contradistinction to the inherently terminal, discontinuous, temporary wealth of the craft eras of civilization such as the Bronze Age or Stone Age. If we only understood how that cumulative industrial wealth has come about, we could stop playing obsolete games, but that is a task that cannot be accomplished by political and social reforms. Man is so deeply conditioned in his reflexes by his millenniums of slave function that he has too many inferiority complexes to yield to political reformation. The obsolete games will be abandoned only when realistic, happier and more interesting games come along to displace the obsolete games.

[WDS Document 3]

Tension and Compression are complementary functions of structure. Therefore as functions they only co-exist. When pulling a tensional rope its girth contracts in compression. When we load a column in compression its girth tends to expand in tension. When we investigate tension and compression, we find that compression members, as you all know as architects, have very limited lengths in relation to their cross sections. They get too long and too slender and will readily break. Tension members, when you pull them tend to pull, approximately, (almost but never entirely), straight instead of trying to curve more and more as do too thin compressionally loaded columns. The contraction of the tension members in their girth, when tensionally loaded, brings its atoms closer together which makes it even stronger. There is no limit ratio of cross section to length in tensional members of structural systems. There is a fundamental limit ratio in compression. Therefore when nature has very large tasks to do, such as cohering the solar system or the universe she arranges her structural systems both in the microcosm and macrocosm in the following manner. Nature has compression operating in little remotely positioned islands, as high energy concentrations, such as the earth and other planets, in the macrocosm; or as isolated electrons, or protons or other atomic nuclear components in the microcosm while cohering the whole universal system, both macro and micro, of mutually remote, compressional, and oft non-simultaneous, islands by comprehensive tension; -compression islands in a non-simultaneous universe of tension. The Universe is a tensegrity.

[WDS Document 2]

I was born cross-eyed. Not until I was four years old was it discovered that this was caused by my being abnormally farsighted. My vision was thereafter fully corrected with lenses. Until four I could see only large patterns, houses, trees, outlines of people with blurred coloring. While I saw two dark areas on human faces, I did not see a human eye or a teardrop or a human hair until I was four. Despite my new ability to apprehend details, my childhood's spontaneous dependence only upon big pattern clues has persisted. . . .

I am convinced that neither I nor any other human, past or present, was or is a genius. I am convinced that what I have every physically normal child also has at birth. We could, of course, hypothesize that all babies are born geniuses and get swiftly de-geniused. Unfavorable circumstances, shortsightedness, frayed nervous systems, and ignorantly articulated love and fear of elders tend to shut off many of the child's brain capability valves. I am lucky in avoiding to many disconnects.

There is luck in everything. My luck is that I was born cross-eyed, was ejected so frequently from the establishment that I was finally forced either to perish or to employ some of those faculties with which we are all endowed-the use of which circumstances had previously so frustrated as to have to put them in the deep freezer, whence only to hellish hot situations could provide enough heat to melt them back into usability.

[WDS Document 5]

In the 1920's with but little open country highway mileage in operation, automobile accidents were concentrated and frequently occurred within our urban and suburban presence. Witnessing a number of accidents, I observed that warning signs later grew up along the roads leading to danger points and that more traffic and motorcycle police were put on duty. The authorities tried to cure the malady by reforming the motorists. A relatively few special individual drivers with much experience, steady temperament, good coordination and natural tendency to anticipate and understand the psychology of others emerged as "good" and approximately accident-free drivers. Many others were accident prone.

In lieu of the after-the-fact curative reform, trending to highly specialized individual offender case histories, my philosophy urged the anticipatory avoidance of the accident potentials through invention of generalized highway dividers, grade separators, clover leafing and adequately banked curves and automatic traffic control stop-lighting systems. I saw no reason why the problem shouldn't be solved by preventative design rather than attempted reforms. My resolve: Reshape environment; don't try to reshape man.

[WDS Document 1]



The Honeywell edition of Fuller's world map (more brightly colored than previous editions) is available.

\$4.00 postpaid

from World Resources Inventory Office, Box 9, Carbondale, Illinois 62901

However, man unconcernedly sorting mail on an express train with unuttered faith that the engineer is competent, that the switchmen are not asleep, that the track walkers are doing their job, that the technologists who designed the train and the rails knew their stuff, that the thousands of others whom he may never know by face or name are collecting tariffs, paying for repairs, and so handling assets that he will be paid a week from today and again the week after that, and that all the time his family is safe and in well being without his personal protection constitutes a whole new era of evolution-the first really "new" since the beginning of the spoken word. In fact, out of the understanding innate in the spoken word was industrialization wrought after millenniums of seemingly whitherless spade work.

[The Unfinished Epic of Industrialization]

The Unfinished Epic of Industrialization by R. Buckminster Fuller, 1963; 227 pp

from World Resources Inventory Office, Carbondale, Illinois 62901

Concept Twelve - SELF DISCIPLINES

Working assumptions, cautions, encourage ments, and restrains of intuitive formulations and spontaneous actions. My own rule: "Do not mind if I am not understood so long as I am not misunderstood."

Personal Self Disciplining. In 1927 I gave up forever the general economic dictum of society, i.e. that every individual who wants to survive must earn a living. I substituted, therefore, the finding made in concept one, i.e., an individual's antientropic responsibility in universe. I sought for the tasks that needed to be done that no one else was doing or attempting to do, which if done would physically and economically advantage society and eliminate pain.

As a consequence, it was necessary for me to discipline my faculties to develop technical and scientific capabilities to invent the physical innovations and their service industry logistics.

Mv Recommendations for a Curriculum of Design Science

1. Synergetics
2. General Systems Theory
3. Theory of Games (Von Neuman)
4. Chemistry and Physics
5. Topology, Projective Geometry
6. Cybernetics
7. Communications
8. Meteorology
9. Geology
10. Biology
11. Sciences of Energy
12. Political Geography
13. Ergonomics
14. Production Engineering

[WDS Document 5]

Order from World Resources Inventory Office, Box 9, Carbondale, Illinois 62901 or World Resources Inventory Office, Box 9, Carbondale, Illinois 62901. Size: 35 x 20 inches.

The will of history reads "for everybody or for nobody," and since we balk at "for nobody" it has to be "for everybody". And that's the way it is going, lickety-split and the world around.

[WDS Document 3]

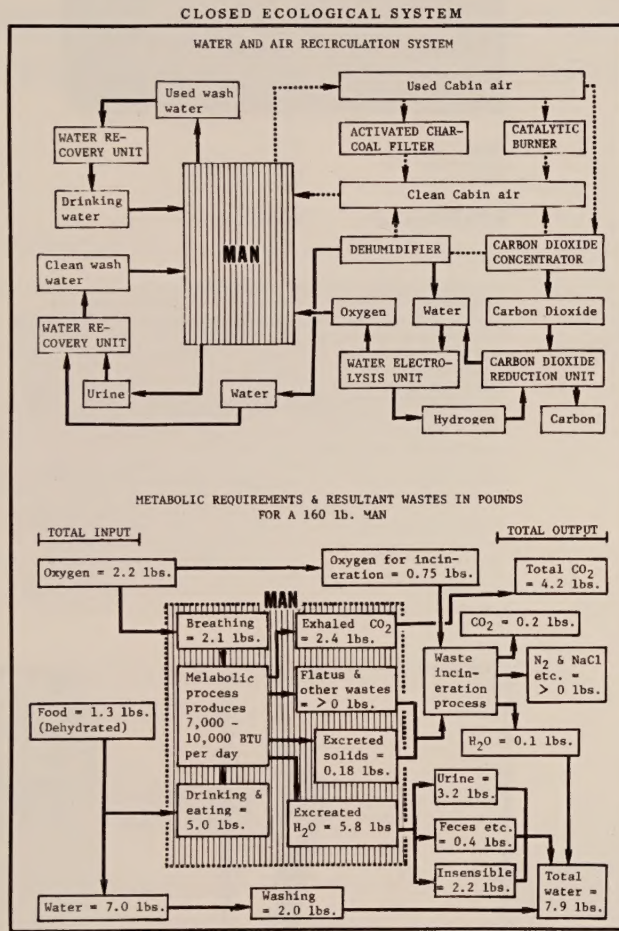

Sources: (1) E. S. Mills, R. L. Butterton, Douglas Missile & Space Systems Development Interplanetary Mission Life Support System, 1965. (2) NASA: ASD Report TR 61-363.

[WDS Document 6]

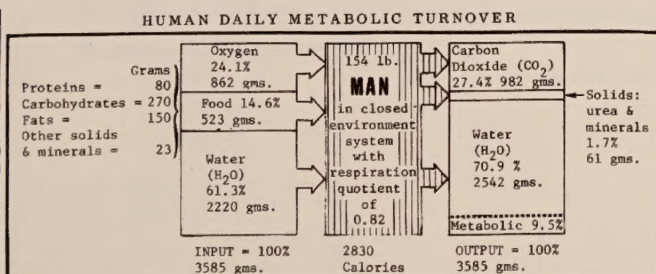
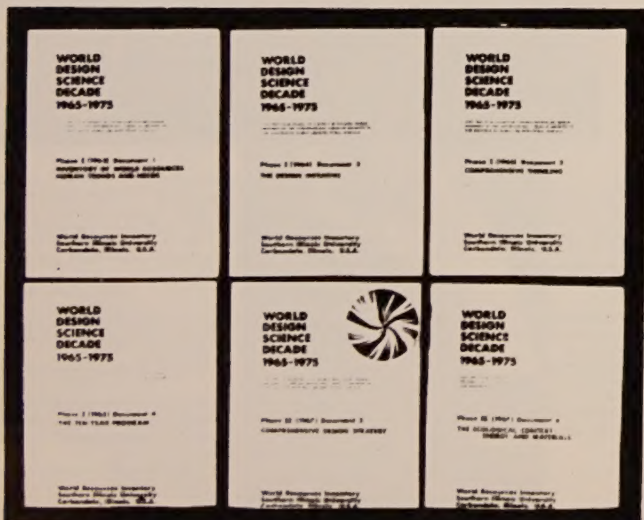

Source: Apogee, Douglas Missile & Space Publication No. 4, 1961. p. 8.

The *World Design Science Decade* documents contain some that is in the other books and much that isn't. The 6 volume set costs \$10.50 postpaid to students (formal and informal); \$30.00 postpaid to others. This is a very good deal.

We find that original question asking is a consequence of interferences, whether in the computer or the human brain. We find then that original questions are second derivative events in the computer life.

[WDS Document 2]

Cosmic View

"The Universe in 40 Jumps" is the subtitle of the book. It delivers.

The man who conceived and rendered it, a Dutch schoolmaster named Kees Boeke, gave years of work to perfecting the information in his pictures. The result is one of the simplest, most thorough, inescapable mind blows ever printed. Your mind and you advance in and out through the universe, changing scale by a factor of ten. It very quickly becomes hard to breathe, and you realize how magnitude-bound we've been.

I'm amazed this book isn't more commonly available. It's the best seller of The Whole Earth Truck Store. People get it for their friends.

Cosmic View from
 The Day Company
 Kees Boeke 67 45th Street
 1957; 48 pp. New York, N.Y.
 \$3.75 postpaid Whole Earth Catalog

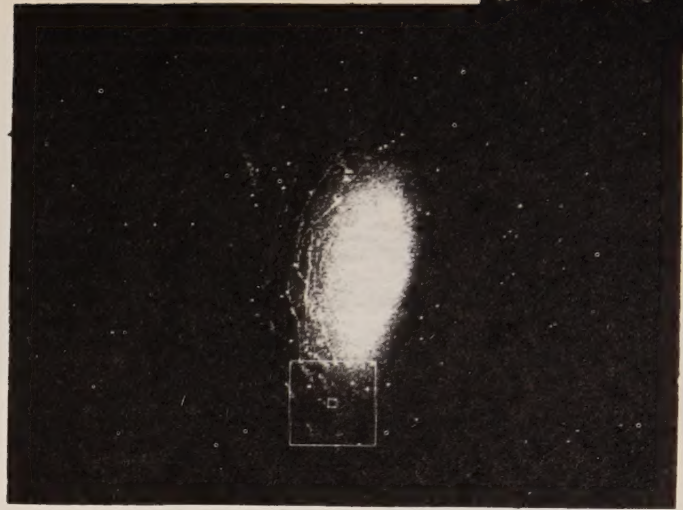
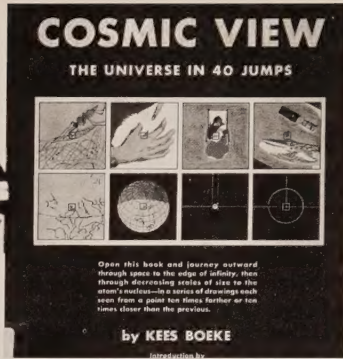

Full Earth

In November 1967 an ATS satellite whose funds phenomenally had not been cut made a home movie. It was a time lapse film of the Earth rotating, shot from 23,000 miles above South America. (This is synchronous distance. The satellite orbits at the same speed the Earth turns, so it remains apparently stationary over one point of the equator.) Color photographs of the Earth were transmitted by TV every 1/2 hour to make up a 24 hour sequence. The shots



Earth photographs

NASA SP-129 is a hell of a book. Two hundred forty-three full page color photographs of our planet from the Gemini flights of 1965. If it were a Sierra Club book, and it could be, it would cost \$25. It costs \$7.

There are numerous discoveries in the book. One is that this beautiful place is scarcely inhabited at all.

were lap dissolved together to make the movie. You see darkness, then a crescent of dawn, then advancing daylight and immense weather patterns whirling and creeping on the spherical surface, then the full round mandala Earth of noon, then gibbous afternoon, crescent twilight, and darkness again.

A 16mm 400-foot silent color print of the film includes several forms of the 24-hour cycle and close-up cropping of specific sectors as their weather develops through the day.

The film (NR 68-713) costs \$48.94 plus shipping
 from Motion Pictures
 67 45th Street
 New York, D.C. 20002

An 8x10 color print of the full earth (68-HC-74) costs \$5.64 postpaid
 from Arts Studio
 1100 14th Street, NW
 Washington, D.C. 20001

Color posters (22x27) of the full earth photographs may be ordered from the WHOLE EARTH CATALOG for \$2.00 postpaid

The posters are available for resale (minimum order 5) at 50% discount.



Earth Photographs from Gemini III, IV, and V.

NASA
 1967; 266 pp.
 \$7.00 postpaid

from: Superintendent of Documents
 U.S. Government Printing Office
 Washington, D.C. 20402
 or Whole Earth Catalog

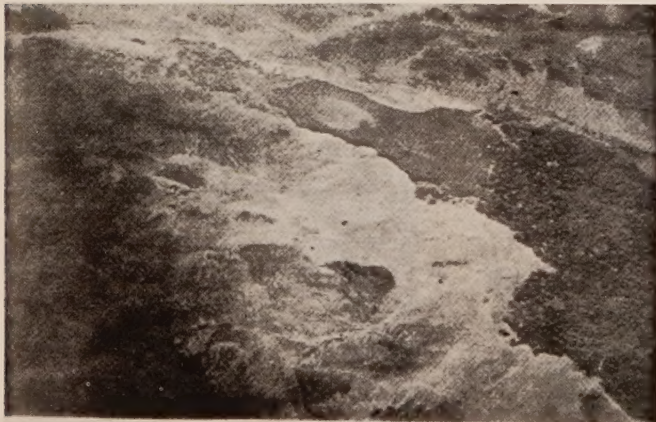

A second photograph of California's Imperial Valley giving a clear view of the Salton Sea. No agreement exists concerning the cause of the gyre seen in the center of the sea.

9-65-13218

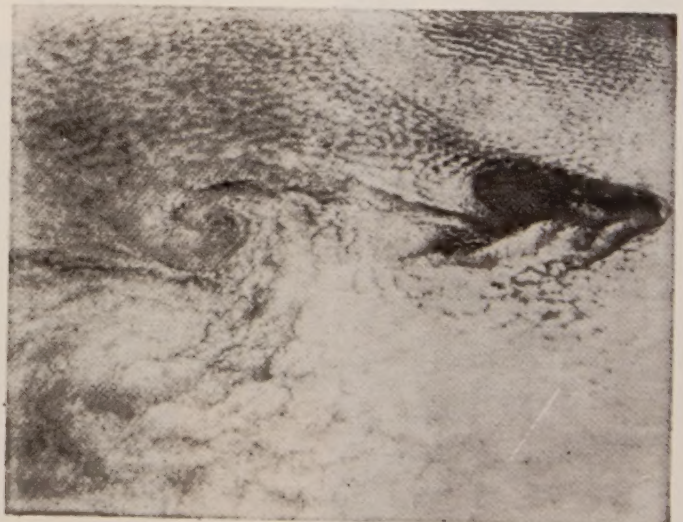

6 Whole Systems

The World From Above

Close-up glamor shots of the Earth. Mystery shots (What is that? What's our altitude above it, 10 feet or 10,000?) (Fold out captions tell all.) Good traffic flow pattern shots: surface anatomy of civilization. Not a bad compendium; it'll do until they reprint E.A. Gutkind's *Our World From the Air*.

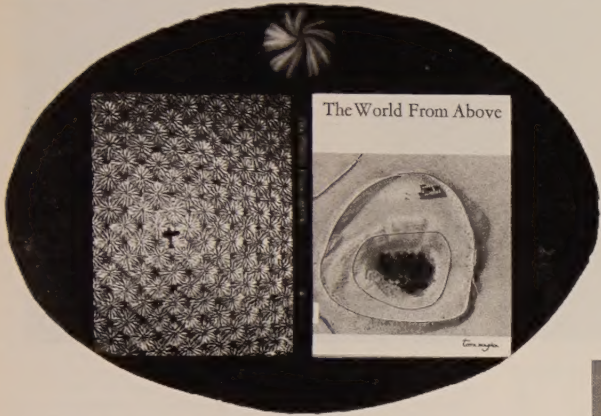

The World From Above

Hanns Reich
1966; 88 pictures
\$7.50 potpaid

from:
Lill and Wang, Inc.
141 Avenue
New York, N.Y. 10010
or
WHOLE EARTH CATALOG

Surface Anatomy

This book is included as a companion piece to the Earth picture books. The whole lovely system of the human creature, seen from without, surface by surface, is here. One of its main revelations is how cliché ridden our usual views of ourselves are - we are still not good with mirrors (satellites were up 10 years before we got a full view of the Earth). Posing friends and neighbors, with a simple light set-up and a 35mm camera, Joseph Royce has shot the most beautiful human album I know.

It also teaches anatomy.

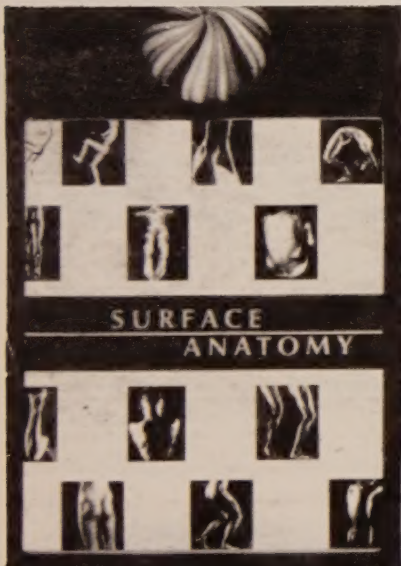

Surface Anatomy

Joseph Royce
1965; 124 photographs
and some diagrams

\$12.50 postpaid

from:
F.A. Davis Company
1915 Locust Street
Philadelphia, Pa 19103
or
WHOLE EARTH CATALOG



Geology Illustrated

A artist of aerial photography, Shelton uses some 400 of his finest photos to illuminate a discussion of the whole-earth system. Not a traditional textbook, but a fascinating exploration of the problems posed by asking "How did that come about?" Worth buying for the photos and book design alone, but you'll probably find yourself becoming interested in geology regardless of your original intentions.

[Reviewed by Larry McCombs]



As a means of communicating geological concepts, the pictures are fully as important as the words that accompany them. On most pages the photographs represent the facts, the words supply the interpretation. Many of the illustrations will, therefore, repay a little of the kind of attention that would be accorded the real feature in the field. In keeping with this, almost no identifying marks have been placed on the photographs and very few on the drawings. The text (which almost invariably concerns an illustration on the same or a facing page) serves as an expanded legend for the picture; if, while reading it, it is necessary to look more than once to identify some feature with certainty, this is no more than Nature asks of those who contemplate her unlabelled cliffs and hills.

Geology Illustrated
John S. Shelton
1966; 434 pp.

\$10.00 postpaid

from
W. H. Freeman & Company
685 Market Street
San Francisco, Ca 94104

WHOLE EARTH CATALOG

Whole 7 Systems

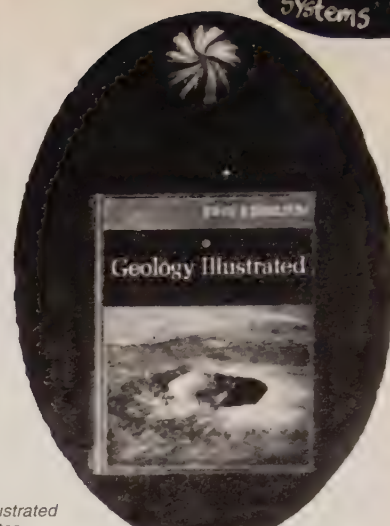

Sensitive Chaos

Schwenk directs an institute in the Black Forest devoted to the study of the movements of water and air. Within the last few centuries, he says we have "lost touch with the spiritual nature of water." As a result, we have attempted to control the fluids in ways contrary to their nature, and the results are evident in the problems of pollution, damage to the ecosystem, and even drying up of natural water sources. Schwenk attempts to penetrate beyond the mere observable phenomena to an ability to "read" the true spiritual nature of flowing substances.

I found the book to be a peculiarly fascinating mixture of overgeneralization, simplification, undifferentiated fact and theory, and shrewd observation and insight. If you regard analogy as the weakest form of argument, this book is definitely not for you. On the other hand, Schwenk's juxtaposition of similar forms in different flowing media may spark some exciting bisociations, if you are open to them. The section of 88 pages of black and white photos at the back of the book could stand alone as a beautiful art collection.

[Reviewed by Larry McCombs]

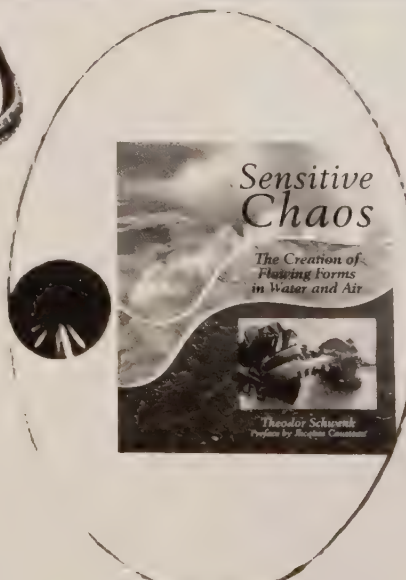
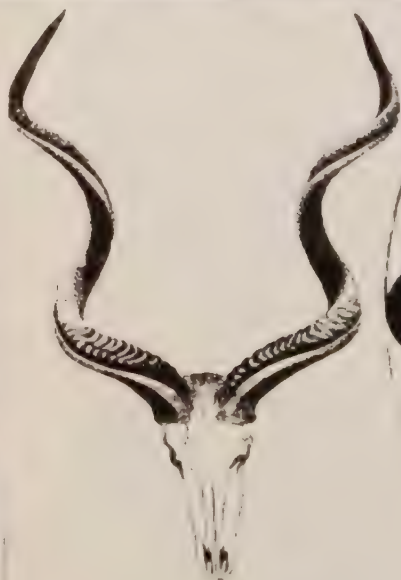
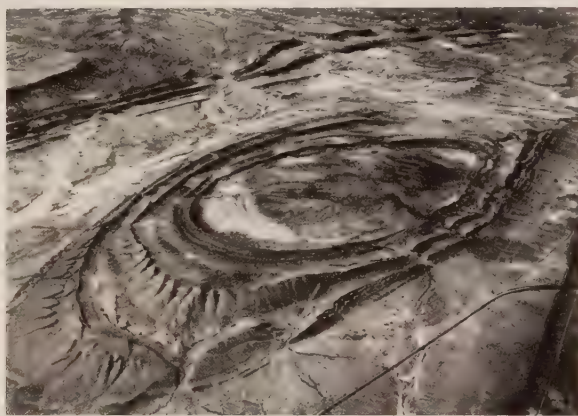

Here too the form of the vortex seems to hover invisibly over the growth processes, even before the horns are actually there, for they proceed along this spiral path with mathematical exactitude in their annual growth. It is significant that the axes of the two spiraling horns meet either in the nose or the eyes or in their immediate vicinity, a fact which stresses the strong connection of the horns with sense perception and with the animal's sense of its surroundings. Furthermore, in structure, the horn, like the water vortex, is finely laminated, layer upon layer.

Sensitive Chaos
Theodor Schwenk
1965; 144 pp. 88 plates

\$12.00 [Air postpaid]

from
Frederick and Joanne Weiner Press
3110 Broadway
New York, NY 10014

or
\$8.70 [postpaid]

from:
WHOLE EARTH CATALOG

The question is: Is my thought changing? It is and it isn't. One evening after dinner, I was telling friends that I was not concerned with improving the world. One of the m said: I thought you always were. I then explained that I believe - and am acting upon - Marshall McLuhan's statement that we have through electronic technology produced an extension of our brains to the world formerly outside of us. To me that means that the disciplines, gradual and sudden (principally Oriental), formerly practiced by individuals to pacify their minds, bringing them into accord with ultimate reality, must now be practiced socially - that is, not just inside our heads, but outside of them, in the world, where our central nervous system now is. This has brought it about that the work and thought of Buckminster Fuller is of prime importance to me. He more than any other to my knowledge sees the world situation - all of it - clearly and has fully reasoned projects for turning our attention away from "killingry" toward "livingry."

Coming back to the notion that my thought is changing. Say it isn't. One thing, however, that keeps it moving is that I'm continually finding new teachers with whom I study. I had studied with Richard Buhlig, Henry Cowell, Arnold Schoenberg, Daisetz Suzuki, Guy Nearing. Now I'm studying with N.O. Brown, Marshall McLuhan, Buckminster Fuller, Marcel Duchamp. In connection with my current studies with Duchamp, it turns out that I'm a poor chessplayer. My mind seems in some respect lacking, so that I make obviously stupid moves. I do not for a moment doubt that this lack of intelligence affects my music and thinking generally. However, I have a redeeming quality: I was gifted with a sunny disposition.

General Systems Yearbook

Everything we come across is to the point. Living underground because there was no money. Arizona land and air permitted making mounds, covering them with cement, excavating to produce rooms, providing these with skylights. For anyone approaching, the community was invisible. Cacti, desert plants: the land seemed undisturbed. Quantity (abundance) changes what's vice, what's virtue. Selfishness is out; carelessness is in. (Waste's



A Year From Monday

John Cage
1967; 167pp.

\$7.92 postpaid

from:
W: University Press
M: n, Conn. 06457
O:
W: ARTH CATALOG

to wait. XXXVI. Weather feels good
Isn't. More rain is needed. Water.
He played two games, winning one, losing
the other. He was continually himself,
totally involved in each game, unmoved
by the outcome of either. What's the
nature of his teaching? For one
thing: devotion (practice gives evidence
of it). For another: not just
playing half the game but playing all of
it (having a view that includes that of
the opponent). Suddenly a clam rose to

consciousness. "They think 'world'.
Theirs will be the most powerful and
constructive revolution in all history."]
LIV. More we leave the land, the more
productive it becomes. Technique for
changing society: education followed by
unemployment. Article by Avner Hovne on
automation (Impact of Science on
Society 15:1, Unesco publication).
Continuity values giving way to flexibility
values. Automation alters what's done and
where we do it. You could always tell
when she was about to go out of her
mind. She would begin to speak the
truth. April '64: fifty-five global

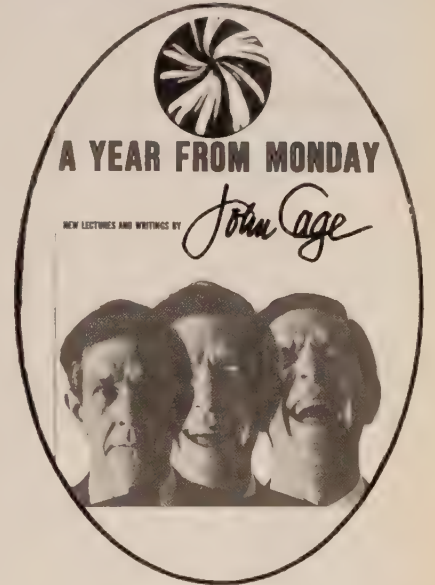

General Systems Yearbook

General systems theory was introduced by biologist Ludwig von Bertalanffy some years back (one application has been systems analysis, which has recomprehended and redesigned much of business, technology, education, etc.). The General Systems Yearbook is edited by Bertalanffy and Anatol Rapoport.

By definition General Systems is a mixed bag. Kinds of systems covered in the Yearbook include Biological, Social, Psychological, Games, Linguistic, Political, Cybernetic and Meteorological. Throughout is the search for common dynamics that transcend them all. It's technical, mathematical business, heavy reading, and maybe trivial, maybe wishful; but ever here and there is a gleam of something that might be a window in to broad mindscapes.

The current volume of the Yearbook (1967) is Volume XII. Titles of articles, working back as far as we have space are:

The price of the Yearbook is
\$10.00 for recent volumes,
\$7.50 for earlier ones.
Consolidated contents booklet available free.
from S or General
S Research
E
E Mass. 01730

VOLUME IX (1964)

- Sociometry and the Physical Sciences
- Prediction in Physics and the Social Sciences
- The Concept of Entropy in Landscape Evolution
- Geomorphology and General Systems Theory
- An Approach to the Conceptual Analysis of Scientific Crises
- A Survey of General Systems Theory
- The Set Theory of Mechanism and Homeostasis
- Constraint Analysis of Many-Dimensional Relations
- The Domain of Adaptive Systems: A Rudimentary Taxonomy
- Language Description of Concepts
- Some Simple Models of Arms Races
- The Problem of Systemic Organizations in Theoretical Biology
- The Conceptual Formulation and Mathematical Solution of Practical Problems in Population Input-Output Dynamics
- The Use of Mathematics and Computers to Determine Optimal Strategies for a Given Insect Pest Control Problem

VOLUME X (1965)

- The Logic of Systems: An Introduction to a Formal Theory of Structure
 - The General System as a Methodological Tool
 - Systems Theory from an Operations Research Point of View
 - Similar Problems in Meteorology and Psychology
 - The Architecture of Complexity
 - On the Emergence of Patterns of Order
 - On the Stability of Brain-Like Structures
 - Some Considerations on the Notion of Invariant Field in Linguistics
 - Toward a Unifying Theory of Cognition
 - Contributions to Stochastic Learning Theory
 - Aspiration Levels and Utility Theory
 - Concession-Making in Experimental Conditions
 - Wheat on Kilimanjaro: The Perception of Choice Within Game and Learning Model Frameworks
 - Models of Southern Kwakiutl Social Organization
 - A Field Theory of Social Action with Application to Conflict
- VOLUME XI (1966)

- Mathematical Aspects of General Systems Theory
- Toward a Theory of Parts and Wholes: An Algebraic Approach
- Meteorology and the Social Sciences: Further Comparisons
- Methodological Problems of System Research
- Metaorganization of Information
- The Insect Corneal Nipple Array
- The Wholeness of Living Systems and Some Basic Biological Problems
- On the Origin of Order in Behavior
- A Cognitive Approach to the Analysis of Cultures and Cultural Evolution
- The University Community System-Self-Regulated Bearer of Meaning
- A Condensation of Warpeace Space
- On Some General Categories of Linguistics
- The Theory of Meta-Games
- The Mathematics of Meta-Games
- Benevolence in Game Theory
- A Taxonomy of 2 x 2 Games
- An Analysis of Duopoly Bargaining
- Two Motivations for Defection in Prisoner's Dilemma Games
- Empirical Approaches to Game Theory and Bargaining: a Bibliography

VOLUME XII (1967)

- The Evolution of the Human Brain: Some Notes Toward a Synthesis Between Neural Structure and the Evolution of Complex Behavior
- Organismic Sets; Outline of a General Theory of Biological and Social Organisms
- The Orderliness of Biological Systems
- Colony Development of a Polymorphic Hydroid as a Problem in Pattern Formation
- A Geometric Model with Some Properties of Biological Systems
- The Regulation of Political Systems
- Types of Asymmetry in Social and Political Systems
- A Quantitative Approach to the Dynamics of Perception
- Some Psychological Aspects of Psychometry
- A Further Extension of General Systems Theory for Psychiatry
- A Dynamic Model of the Conflict Between Criminals and Society
- Some Comparisons Between Traffic Deaths and Suicide
- Crime Rate vs. Population Density in United States Cities: A Model
- Simulation of Socio-Economic Systems
- An Empirical Test of Five Assumptions in an Inter-National Simulation About National Political Systems

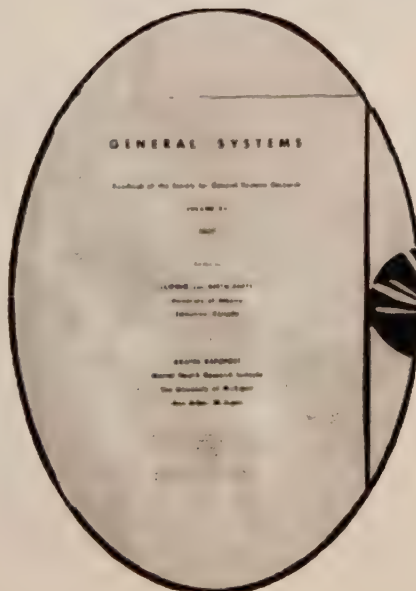

Christopher Alexander is a design person that other people refer to a lot. This book deals with the nature of current design problems that are expanding clear beyond any individual's ability to know and correlate all the factors. The methodology presented here is one of analysis of a problem for misfits and synthesis of form (via computer-translatable nets and hierarchies) for minimum misfits.

(From the table of contents)

2. Goodness of Fit	15
3. The Source of Good Fit	28
4. The Unselfconscious Process	46
5. The Selfconscious Process	55

But if we think of the requirements from a negative point of view, as potential misfits, there is a simple way of picking a finite set. This is because it is through misfit that the problem originally brings itself to our attention. We take just those relations between form and context which obtrude most strongly, which demand attention most clearly, which seem most likely to go wrong. We cannot do better than this. If there were some intrinsic way of reducing the list of requirements to a few, this would mean in essence that we were in possession of a field description of the context: if this were so, the problem of creating fit would become trivial, and no longer a problem of design. We cannot have a unitary or field description of a context and still have a design problem worth attention.

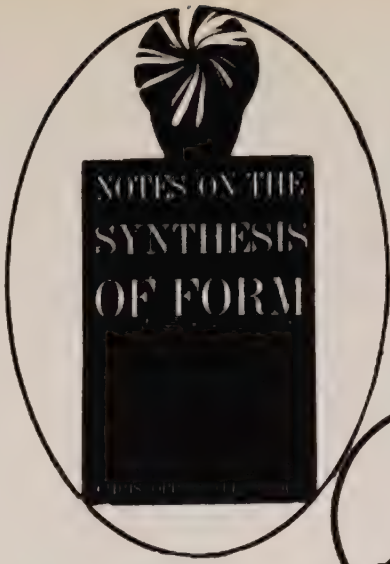

Indeed, not only is the man who lives in the form the one who made it, but there is a special closeness of contact between man and form which leads to constant rearrangement of unsatisfactory detail, constant improvement. The man, already responsible for the original shaping of the form, is also alive to its demands while he inhabits it. Any anything which needs to be changed is changed at once.

A subsystem, roughly speaking, is one of the obvious components of the system, like the parts shown with a circle round them. If we try to adjust a set of variables which does not constitute a subsystem, the repercussions of the adjustment affect others outside the set because the set is not sufficiently independent. The procedure of the unselfconscious system is so

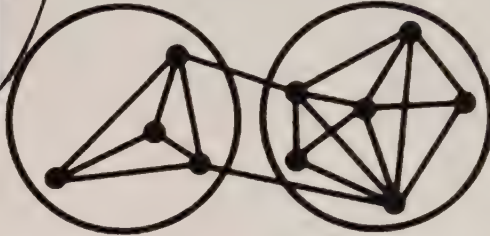

organized that adjustment can take place in each one of these subsystems independently. This is the reason for its success. In the selfconscious situation, on the other hand, the designer is faced with all the variables simultaneously

The greatest clue to the inner structure of any dynamic process lies in its reaction to change.

The Mousgoum cannot afford, as we do, to regard maintenance as a nuisance which is best forgotten until it is time to call the local plumber. It is in the same hands as the building operation itself, and its exigencies are as likely to shape the form as those of the initial construction.

The selfconscious individual's grasp of problems is constantly misled. His concepts and categories, besides being arbitrary and unsuitable, are self-perpetuating. Under the influence of concepts, he not only does things from a biased point of view, but sees them biasedly as well. The concepts control his perception of fit and misfit - until in the end he sees nothing but deviations from his conceptual dogmas, and loses not only the urge but even the mental opportunity to frame his problems more appropriately.

The solution of a design problem is really only another effort to find a unified description. The search for realization through constructive diagrams is an effort to understand the required form so fully that there is no longer a rift between its functional specification and the shape it takes.

Two misfits are seen to interact only because, in some sense at least, they deal with the same kind of physical consideration. It is such a physical center of implication, if I may call it that, which the designer finds it easy to grasp. Because it refers to a distinguishable physical property or entity, it can be expressed diagrammatically and provides a possible non-verbal point of entry into the problem.

On Growth and Form

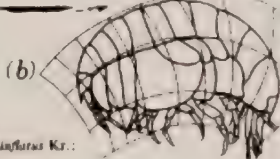

Fig. 143. (a) *Harpinia plumosa* Kr., (b) *Stegocephalus inflatus* Kr., (c) *Hyperva galba*

A paradigm classic. Everyone dealing with growth or form in any manner can use the book. We've seen worn copies on the shelves of artists, inventors, engineers, computer systems designers, biologists. Would one of you do a thorough review of D'Arcy Thompson's venerable book for the CATALOG?

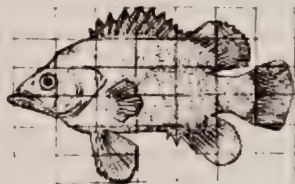

Fig. 150. *Polygona*
Polygona punctata (Schmiedeknecht)

When Plateau made the wire framework of a regular tetrahedron and dipped it in soap-solution, he obtained in an instant a beautifully symmetrical system of six films, meeting three by three in four edges and those four edges running from the corners of the figure to its centre of symmetry. Here they meet, two by two, at the Maraldi angle; and the films meet three by three, to form the re-entrant solid angle which we have called a 'Miraldi pyramid' in our account of the architecture of the honeycomb. The very same configuration is easily recognized in the minute siliceous skeleton of *Callimitta*. There are two discrepancies, neither of which need raise any difficulty. The figure is not rectilinear but a spherical tetrahedron, such as might be formed by the boundary edges of a tetrahedral cluster of four co-equal bubbles; and just as Plateau extended his experiment by blowing a small bubble in the centre of his tetrahedral system, so we have a central bubble also here. This bubble may be of any size; but its situation (if it be present at all) is always the same, and its shape is always such as to give the Maraldi angles at its own four corners. The tension of its own walls, and those of the films by which it is supported or slung, all balance one another. Hence the bubble appears in plane projection as a curvilinear equilateral triangle; and we have only got to convert this plane diagram into the corresponding solid to obtain the spherical tetrahedron we have been seeking to explain (Fig. 63).

The geometry of the little inner tetrahedron is not less simple and elegant. Its six edges and four faces are all equal. The films attaching it to the outer skeleton are all planes. Its faces are spherical,

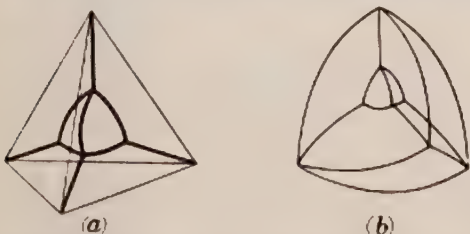

Fig. 63. Diagrammatic construction of *Callimitta*. (a) A bubble suspended within a tetrahedral cage; (b) another bubble within a skeleton of the former bubble.

and each has its centre in the opposite corner. The edges are circular arcs, with cosine $\frac{1}{2}$; each is in a plane perpendicular to the chord of the arc opposite, and each has its centre in the middle of that chord. Along each edge the two intersecting spheres meet each other at an angle of 120° .



Fig. 67. A Nassellarian skeleton, *Callimitta argusae* (Hil) 10-11 mm diameter

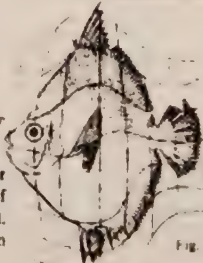

Fig. 153. *Antigonia caprus*.

The engineer, who had been busy designing a new and powerful crane, saw in a moment that the arrangement of the bony trabeculae was nothing more nor less than a diagram of tension and compression, in the loaded structure, in short, that Nature was strengthening the bone in precisely the manner and direction in which strength was required; and he is said to have cried out, 'That's my crane!'



On Growth and Form
D'Arcy Wentworth Thompson
Two volume edition
1917, 1952

\$27.50 postpaid
Abridged paper edition
1917, 1961; 346 pp.

\$2.45 postpaid

Both from:
Cambridge University Press
57 Avenue
New York, N.Y. 10801
or
WILEY-INTERSCIENCE CATALOG

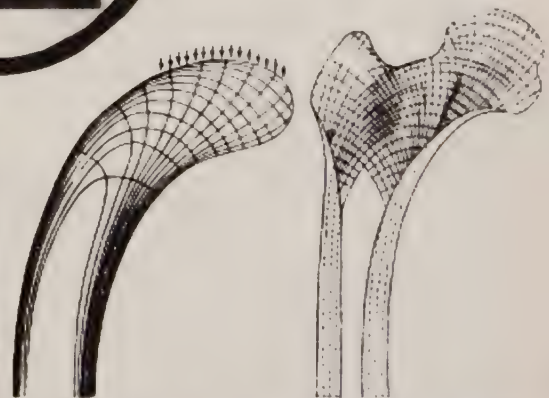

Fig. 101. Crane-head and femur. After Culmann and J. Wolf



Fig. 155. *Antigonia caprus*.

TANTRA ART

EVERY PHENOMENAL OBJECT IS THE CONCENTRATION & REFLECTION OF A CERTAIN PATTERN

IN THIS WAY ART IS A PATH TOWARD TRUTH & REALIZATION OF THE SELF

YANTRA IS AN APPARATUS TO CONNECT ONE OUTSIDE TIME & SPACE IN ETERNITY

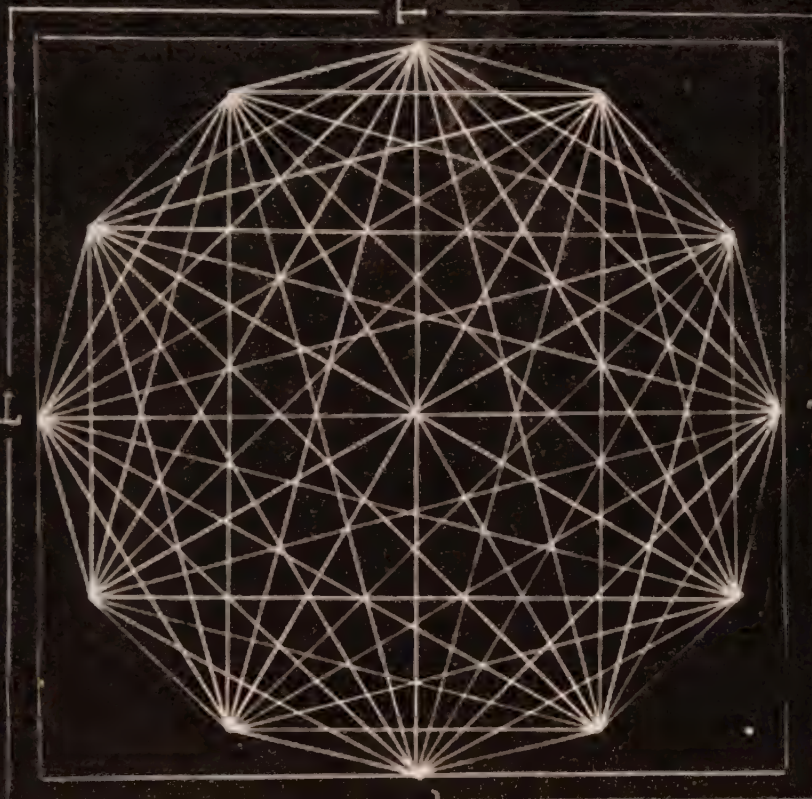

TANTRA

TANTRA

TANTRA

TANTRA

THERE EXISTS NO FORM OF CONCENTRATION MORE ABSOLUTE THAN THE CREATION OF IMAGES

FOR ANY ONE INTERESTED IN YANTRA, MANDALAS, ARCHETYPAL ART, "OBJECTIVE" ART THIS BOOK IS INVALUABLE. INCREDIBLE COLOR (B&W) REPRODUCTIONS OF WORKS NOT USUALLY AVAILABLE OR ATTAINABLE. THIS BOOK WILL BECOME A STANDARD DICTIONARY FOR "OBJECTIVE" LANGUAGE STUDY. RECOMMEND CONCURRENT READINGS OF TUCCI'S "THEORY & PRACTICE OF THE MANDALA" AS TEXT, WHILE POETIC & INTERESTING, IS NOT PRECISE OR SPECIFIC ENOUGH FOR THOSE DESIRING ALL DE TALES.

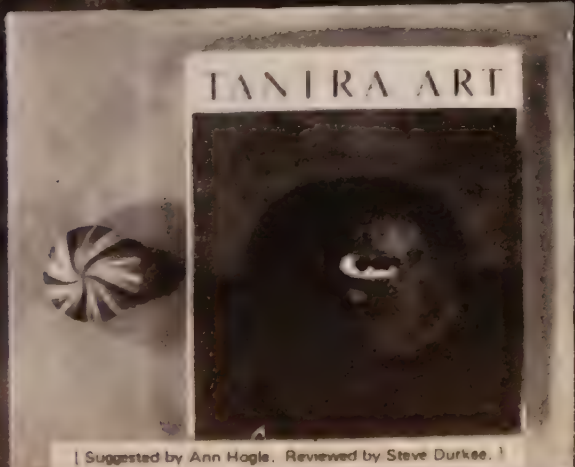

[Suggested by Ann Hogle. Reviewed by Steve Durkee.]

"What is here, is elsewhere.
What is not here, is nowhere."

Visvasara Tantra

Tantra Art

Ajit Mookerjee
1966 100 pp

from: Ravi Kumar
2, Ave du President Kennedy
Paris 16^e, France

\$33.00 postpaid

SOLE EARTH CATALOG

[This is the only art book in the CATALOG]

Psychological Reflections



Jung in capsules and tasting like medicine.

The selection and editing of paragraphs from Jung's writings by Jacobi is done with an informed sense of continuity, so that the book is readable in sequence or by bits.

In a world increasingly subjective, everybody is psychologists to one another. Here is one master book of tools.

Psychological Reflections
C.G. Jung [ed. Jacobi]
1945, 1953, 1961: 340 pp.

\$2.25 postpaid

From
H. Row
45 3rd Street
New York, N.Y. 10016
or
WORLD EARTH CATALOG

The man who would learn the human mind will gain almost nothing from experimental psychology. Far better for him to put away his academic gown, to say good-bye to the study, and to wander with human heart throughout the world. There, in the horrors of the prison, the asylum, and the hospital, in the drinking-shops, brothels, and gambling hells, in the salons of the elegant, in the exchanges, socialist meetings, churches, religious revivals, and sectarian ecstasies, through love and hate, through the experience of passion in every form in his own body, he would reap richer store of knowledge than text-books a foot thick could give him. The would he know to doctor the sick with real knowledge of the human soul.

A neurosis has really come to an end when it has overcome the wrongly ego. The neurosis itself is not healed; it heals us. The man is ill, but the illness is an attempt of nature to heal him. We can therefore learn a great deal for the good of our health from the illness itself, and that which appears to the neurotic person as absolutely to be rejected is just the part which contains the true gold which we should otherwise never have found.

The secret of the earth is not a joke and not a paradox. We need only see how in American the skull- and hip-measurements of all European races become Indianized in the second generation. That is the secret of the American soil. And every soil has its secret, of which we carry an unconscious image in our souls: a relationship of spirit to body and of body to earth.

The greater the contrast, the great the potential. Great energy only comes from a correspondingly great tension between opposites.

No one develops his personality because someone told him it would be useful or advisable for him to do so. Nature has never yet allowed herself to be imposed upon by well-meaning advice. Only coercion working through casual connections moves nature, and human nature also. Nothing changes itself without need, and human personality least of all. It is immensely conservative, not to say inert. Only the sharpest need is able to rouse it. The development of personality obeys no wish, no command, and no insight, but only need; it wants the motivating coercion of inner or outer necessities. Any other development would be individualism. This is why the accusation of individualism is a cheap insult when it is raised against the natural development of personality.

It is naturally a fundamental error to believe that if we see an anti-value in a value, or an untruth in a truth, the value or the truth is then invalid. They have only become relative. Everything human is relative, because everything depends upon an inner polarity, for everything is a phenomenon of energy. And energy itself necessarily depends on a previous polarity without which there can be no energy. There must always be high and low, hot and cold, etc., so that the process of adjustment which is energy, can occur. The tendency to deny all previous values in favour of their opposites is therefore just as exaggerated as the former one-sidedness. Where generally accepted and undoubted values are suddenly thrown away, there is a fatal loss. Whoever acts in this way ends by throwing himself overboard with the discarded values.

The gigantic catastrophes that threaten us are not elemental happenings of a physical or biological kind, but are psychic events. We are threatened in a fearful way by wars and revolutions that are nothing else than psychic epidemics. At any moment a few million people may be seized by a madness, and then we have another world war or devastating revolution. Instead of being exposed to wild beasts, tumbling rocks and inundating waters, man is exposed today to the elemental forces of his own psyche. Psychic life is a world-power that exceeds by many times all the powers of the earth. The Enlightenment, which stripped nature and human institutions of goods, overlooked the one god of fear who dwells in the psyche. Fear of God is in place, if anywhere, before the domination power of psychic life.

No doubt it is a great nuisance that mankind is not uniform but compounded of individuals whose psychic structure spreads them over a span of at least ten thousand years. Hence there is absolutely no truth that does not spell salvation to one person and damnation to another. All universalisms get stuck in this terrible dilemma.

The Human Use of Human Beings

Whole Systems 11

Norbert Wiener is one of the founders of an n-dimensional inhabited world whose nature we've yet to learn. He is also one of the all-time nice men.

*A proper sequel to his *Cybernetics* (see p. 32), this book is social, untechnical, ultimate in most of its consideration. Its domain is the whole earth of the mind.*

The Human Use of Human Beings
Norbert Wiener
1950, 1954; 288pp

\$1.25

From
A Books
2 55th Street
New York, N.Y. 10019
or in book stores



It is the thesis of this book that society can only be understood through a study of the messages and the communication facilities which belong to it; and that in the future development of these messages and communication facilities, messages between man and machine and between machine and machine, are destined to play an ever-increasing part.

Messages are themselves a form of pattern and organization. Indeed, it is possible to treat sets of messages as having an entropy like sets of states of the external world. Just as entropy is a measure of disorganization, the information carried by a set of messages is a measure of organization. In fact, it is possible to interpret the information carried by a message as essentially the negative of its entropy, and the negative logarithm of its probability. That is, the more probable the message, the less information it gives. Clichés, for example, are less illuminating than great poems.

I believe that Ashby's brilliant idea of the unpurposeful random mechanism which seeks for its own purpose through a process of learning is not only one of the great philosophical contributions of the present day, but will lead to highly useful technical developments the task of automatization. Not only can we build purpose into machines, but in an overwhelming majority of cases a machine designed to avoid certain pitfalls of breakdown will look for purposes which it can fulfill.

We are not stuff that abides, but patterns that perpetuate themselves. A pattern is a message, and may be transmitted as a message

It is illuminating to know that the sort of phenomenon which is recorded subjectively as emotion may not be merely a useless epiphenomenon of nervous action, but may control some essential stage in learning, and in other similar processes.

It is the great public which is demanding the utmost of secrecy for modern science in all things which may touch its military uses. This demand for secrecy is scarcely more than the wish of a sick civilization not to learn the progress of its own disease

The Ghost in the Machine

Koestler's latest book seems to be sharing the fate of Norman O. Brown's *Love's Body*: the book after the big influential one (*Act of Creation, Life Against Death*) is considered too far out, fragmented, excessive . . . and sells half-heartedly.

Nevermind. Koestler here is doing useful dirty work: saving rat psychology, exploring broader implications of biological systems research, and foreseeing our imminent demise unless we organize our brain-use better. Which brings him to drugs. He proposes research to find a chemical which will voluntarily disengage old-brain from new-brain—the interior emotional kill-heavy unprogrammable stuff from exterior rational flexible stuff. Our paranoia is accidentally designed in, he suggests, and may be designed out. Get to it outlaws. No nation is going to support this research.



The Ghost in the Machine

Arthur Koestler
1967; 384 pp.
\$6.95 postpaid

from:
Macmillan Company
Front and Brown Streets
Richmond, Burlington County
New Jersey 08075
or
W.H. ARTH CATALOG

The Year 2000

Is Herman Kahn the bad guy (as liberal opinion would have it) or a good guy (as in some informed opinion)? Kahn will hang you on that question and while you're hanging jam information and scalding notions into your ambivalence. He does this best with a live audience, but this book is a fine collection of the information he uses.

Here is most of the now-basic methodology of future study—multi-fold trends, surprise-free projections, scenarios, etc. And here are their results. It's the best future-book of the several that are out.

In my opinion, it is not particularly an accurate picture of the future but the most thorough picture we have of the present—the present statistics, present fantasies, present expectations that we're planning with. We are what we think our future is.

If computer capacities were to continue to increase by a factor of ten every two or three years until the end of the century (a factor between a hundred billion and ten quadrillion), then all current concepts about computer limitations will have to be reconsidered. Even if the trend continues for only the next decade or two, the improvements over current computers would be factors of thousands to millions. If we add the likely enormous improvements in input-output devices, programming and problem formulation, and better understanding of the basic phenomena being studied, manipulated, or simulated, these estimates of improvement may be wildly conservative. And even if the rate of change slows down by several factors, there would still be room in the next thirty-three years for an overall improvement of some five to ten orders of magnitude. Therefore, it is necessary to be skeptical of any sweeping but often meaningless or nonrigorous statements such as "a computer is limited by the designer—it cannot create anything he does not put in," or that "a computer cannot be truly creative or original." By the year 2000, computers are likely to match, simulate, or surpass some of man's most "human-like" intellectual abilities, including perhaps some of his aesthetic and creative capacities, in addition to having some new kinds of capabilities that human beings do not have. These computer capacities are not certain; however, it is an open question what inherent limitations computers have. If it turns out that they cannot duplicate or exceed certain characteristically human capabilities, that will be one of the most important discoveries of the twentieth century.

The Year 2000
Herman Kahn and Anthony J. Wiener
1967; 431 pp.
\$9.95 postpaid

from:
The Macmillan Company
Front and Brown Streets
Richmond, Burlington County
New Jersey 08075
or
W.H. ARTH CATALOG

ESCAPE FROM SPECIALIZATION

There is now strong evidence in favour of the theory, proposed by Garstang as far back as 1928, that the chordates—and thus, we the vertebrates—are descended from the larval stage of some primitive echinoderm, perhaps rather like the sea-urchin or sea cucumber (echinoderm = "prickly-skinned"). Now an adult sea cucumber would not be a very inspiring ancestor—it is a sluggish creature which looks like an ill-stuffed sausage with leathery skin, lying on the sea bottom. But its free-floating larva is a much more promising proposition: unlike the adult sea cucumber, the larva has bilateral symmetry like a fish; it has a ciliary band—a forerunner of the nervous system—and some other sophisticated features not found in the adult animal. We must assume that the sedentary adult residing on the sea bottom had to rely on mobile larvae to spread the species far and wide in the ocean, as plants scatter their seeds in the wind; that the larvae, which had to fend for themselves, exposed to much stronger selective pressures than the adults, gradually became more fish-like; and that eventually they became sexually mature while still in the free-swimming, larval state—thus giving rise to a new type of animal which never settled on the bottom at all, and altogether eliminated the senile, sedentary cucumber stage from its life history.

This speeding up of sexual maturation relative to the development of the rest of the body—or, to put it differently, the gradual retardation of bodily development beyond the age of sexual maturation—is a familiar evolutionary phenomenon, known as neoteny. Its result is that the animal begins to breed while still displaying larval or juvenile features; and it frequently happens that the fully adult stage is never reached—it is dropped off the life cycle.

This tendency towards a 'prolonged childhood', with the corresponding squeezing out of the final adult stages, amounts to a rejuvenation and de-specialization of the race—an escape from the cul-de-sac in the evolutionary maze. As J.Z. Young wrote, adopting Garstang's views: 'The problem which remains is in fact not "how have vertebrates been formed from sea squirts?" but "how have vertebrates eliminated the (adult) sea squirt stage from their life history?" It is wholly reasonable to consider that this has been accomplished by paedomorphosis.' . . .

Neoteny in itself is of course not enough to produce these evolutionary bursts of adaptive radiations. The 'rejuvenation' of the race merely provides the opportunity for evolutionary changes to operate on the early, malleable phases of ontogeny: hence paedomorphosis, 'the shaping of the young'. In contrast to it, gerontomorphosis (geras = old age) is the modification of fully adult structures which are highly specialized. This sounds like a rather technical distinction, but it is in fact of vital importance. Gerontomorphosis cannot lead to radical changes and new departures; it can only carry an already specialized evolutionary line one more step further in the same direction—as a rule into the dead end of the maze. . . .

DRAW BACK TO LEAP

It seems that this retracing of steps to escape the dead ends of the maze was repeated at each decisive evolutionary turning point. I have mentioned the evolution of the vertebrates from a larval form of some primitive echinoderm. Insects have in all likelihood emerged from a millipede-like ancestor—not, however, from adult millipedes, whose structure is too specialized, but from their larval forms. The conquest of the dry land was initiated by amphibians whose ancestry goes back to the most primitive type of lung-breathing fish; whereas the apparently more successful later lines of highly specialized gill-breathing fishes all came to a dead end. The same story was repeated at the next major step, the reptiles, who derived from early, primitive amphibians—not from any of the later forms that we know.

And lastly, we come to the most striking case of paedomorphosis, the evolution of our own species. It is not generally recognized that the human adult resembles more the embryo of an ape rather than an adult one.

Figure 10 is from Garstang's original paper, and is meant to represent the process of evolution by paedomorphosis. Z to Z9 is the progression of zygotes (fertilized eggs) along the evolutionary ladder; A to A9 represents the adult forms resulting from each zygote. Thus the black line from Z4 to A4, for instance, represents ontogeny, the transformation of egg into adult; the dotted line from A to A9 represents phylogeny—the evolution of higher forms. But note that the thin lines of evolutionary progress do not lead directly from, say, A4 to A5—that would be gerontomorphosis, the evolutionary transformation of an adult form. The line of progress branches off from the unfinished embryonic stage of A4. This represents a kind of evolutionary retreat from the finished product, and a new departure toward the evolutionary novelty Z5-A5. A4 could be the adult sea cucumber; then the branching-off point on the line A4-Z4 would be its larva; or A8 could be the adult primate ancestor of man, and the branching-off point its embryo—which is so much more like the A9—ourselves.

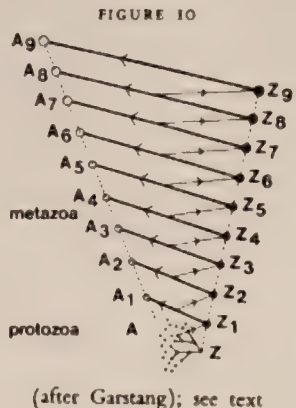

But Garstang's diagram could also represent a fundamental aspect of the evolution of ideas. . . .

The revolutions in the history of science are successful escapes from blind alleys. The evolution of knowledge is continuous only during those periods of consolidation and elaboration which follow a major break-through. Sooner or later, however, consolidation leads to increasing rigidity, orthodoxy, and so into the dead end of overspecialization—to the koala bear. Eventually there is a crisis and a new 'break-through' of the blind alley—followed by another period of consolidation, a new orthodoxy and so the cycle starts again.

But the theoretical structure which emerges from the break-through is not built on top of the previous edifice; it branches out from the point where progress has gone wrong. The great revolutionary turns in the evolution of ideas have a decidedly paedomorphic character. Each zygote in the diagram would represent a seminal idea, the seed out of which a new theory develops until it reaches adult, fully matured stage. One might call this the ontogeny of a theory. The history of science is a series of such ontogenies. True, novelties are not derived directly from a previous adult theory, but from a new seminal idea—not from the sedentary sea urchin but from its mobile larva. Only in the quiet periods of consolidation do we find gerontomorphosis—small improvements added to a fully grown established theory. . . .

At first sight the analogy may appear far-fetched; I shall try to show that it has a solid factual basis. Biological evolution is to a large extent a history of escapes from the blind alleys of overspecialization: the evolution of ideas a series of escapes from the bondage of mental habit; and the escape mechanism in both cases is based on the principle of undoing and re-doing, the draw-back-to-leap pattern.

The Futurist

In part because the Future is a new field of methodic study, this is a lively newsletter. It reports bi-monthly on new books, books and programs having anything to do with social forecasting. Future study is like education: everybody thinks they're good at it. The newsletter has some of that diluted flavor, but it doesn't matter. Useful pointing at useful activities done here.

from:
Future Society
P.O. Box 9285
20001 Washington Station
Washington, D.C. 20036

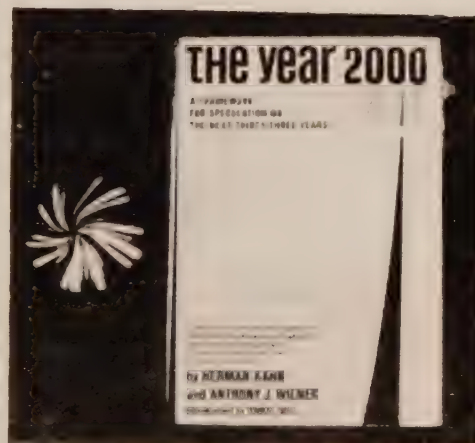
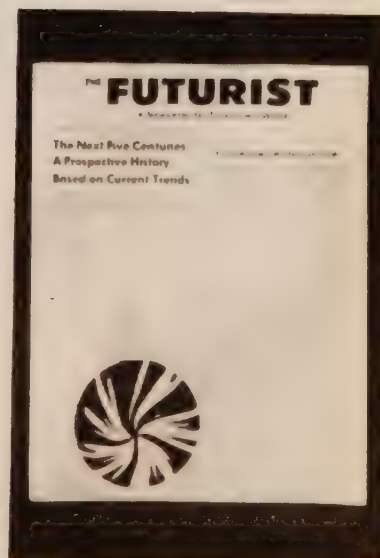

TABLE IX
The Postindustrial (or Post-Mass Consumption) Society

1. Per capita income about fifty times the preindustrial
2. Most "economic" activities are tertiary and quaternary (service-oriented), rather than primary or secondary (production-oriented)
3. Business firms no longer the major source of innovation
4. There may be more "consentives" (vs. "marketives")
5. Effective floor on income and welfare
6. Efficiency no longer primary
7. Market plays diminished role compared to public sector and "social accounts"
8. Widespread "cybernation"
9. "Small world"
10. Typical "doubling time" between three and thirty years
11. Learning society
12. Rapid improvement in educational institutions and techniques
13. Erosion (in middle class) of work-oriented, achievement-oriented, advancement-oriented values
14. Erosion of "national interest" values
15. Sensate, secular, humanist, perhaps self-indulgent criteria become central



The Dymaxion World of Buckminster Fuller

The most graphic of Fuller's books (it's about his work, by Robert Marks). Consequently it is the most directly useful if you are picking up on specific projects of his such as domes, geometry, cars, demographic maps and charts, etc.

The Dymaxion World of Buckminster Fuller
 Robert W. Marks from:
 1960; 232 pp. Sc Illinois University
 P
\$10.00 postpaid 6: Grand

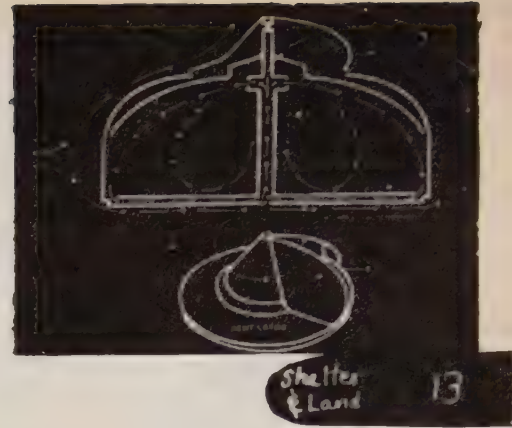
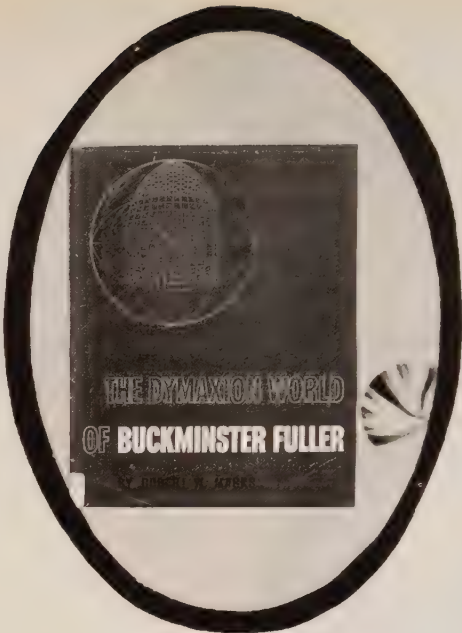

Fuller Sun Dome

The most readily available plans for a geodesic dome are these. The \$5 cost includes construction license. Built of wood strips and cheap polyethylene skin, the dome can be built up to 30 feet diameter. For more elaborate plans you should correspond with Fuller's office, Box 909, Carbondale, Illinois. [Suggested by Ken Babbs]

Geodesic Sun Dome from:
 1966 Sun Dome
\$5.00 postpaid Science Monthly
 1400 Connecticut Avenue
 N.W., Washington, D.C. 20004

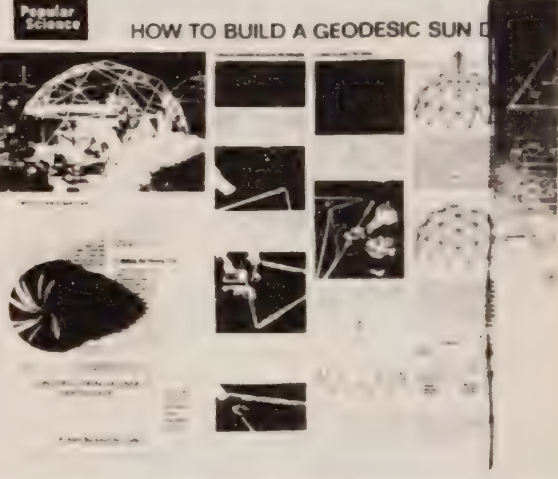
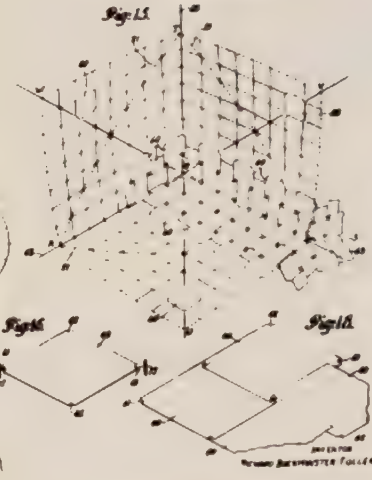
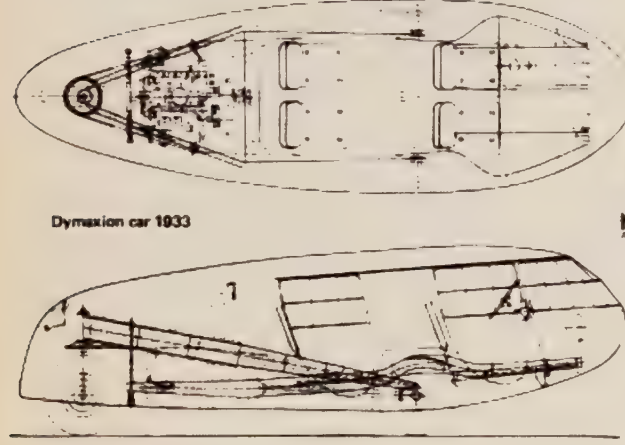
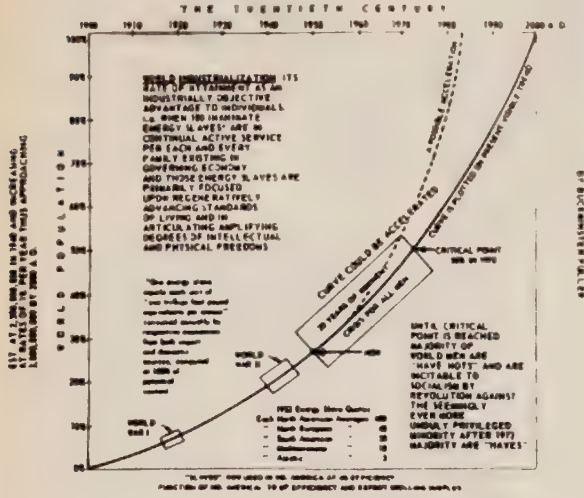

Space Structures

This is a big fat reference book on domes, trusses, cable nets, forms that will keep the rain out in a big way, or elegantly hold water or electric lines up in the air. The book resulted from the International Conference on Space Structures held in London in 1966. It's said to be the first comprehensive book book of its kind. Very heavy book; it'll either help you or discourage you, depending on how far into construction you are.

We could use an informed review on this one. If we don't get it we'll drop the book.

Space Structures
 R.M. Davies, ed.
 1967; 1233 pp.
\$46.50 postpaid

from:
 John Wiley & Sons, Inc.
 605 Third Ave.
 New York, N.Y. 10016
 or
 John Wiley & Sons, Inc.
 Distribution Center
 1515 Redwood Road
 Salt Lake City, Utah 84104

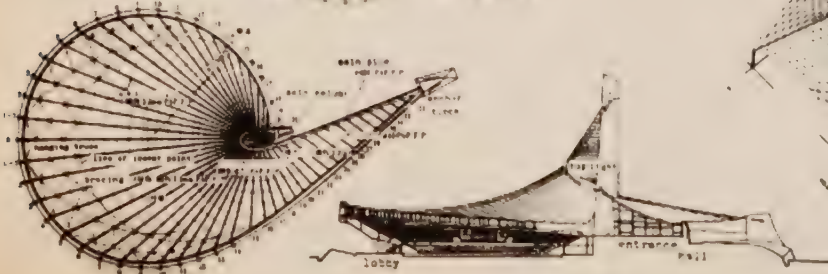
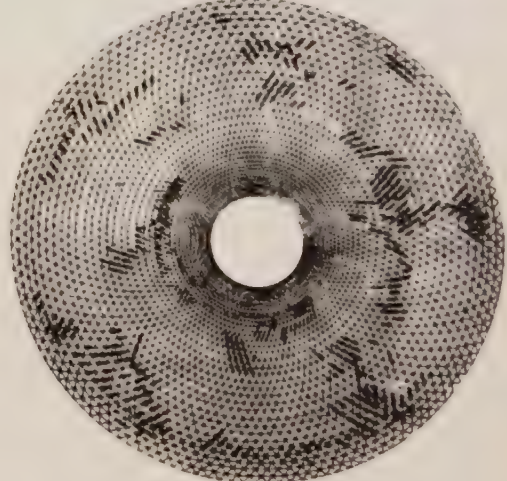
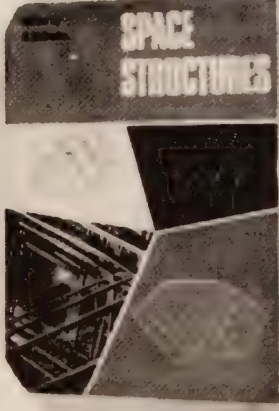

Figure 1. Roof plan and section.

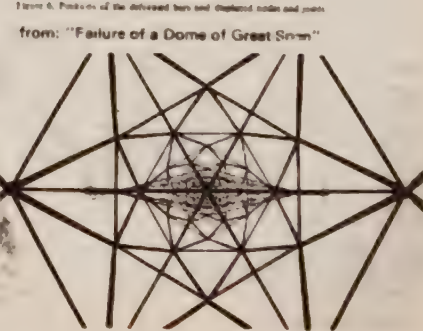
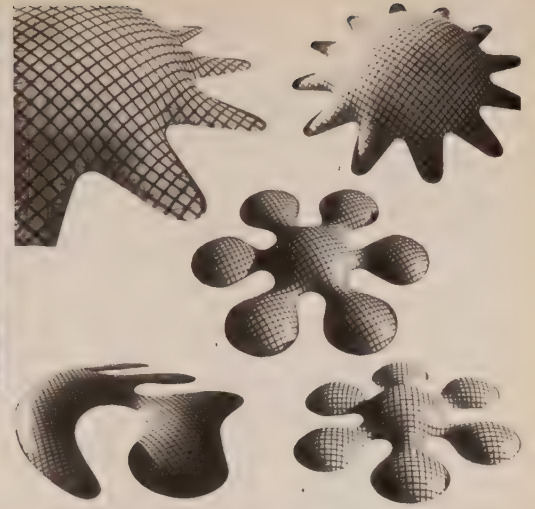

Figure 2. View looking up and from the center of the dome.

Tensile Structures, Volume One

The only pavillon of Expo 67 more beautiful than Fuller's U.S. Dome was the West German tent, designed by Frei Otto. He is currently the master of structures whose flexible skin is the prime structural element. Volume One of his 2-Volume work is devoted to Pneumatic Structures - air houses plus. Every designer we know who's seen this book has commenced to giggle and point, jump up and down, and launch into enthusiastic endorsement of Otto, design, being a designer, and look at this [here](#). The book is comprehensive in its field, tech-



14 Shelter & Land

nically thorough, beautifully presented. Volume Two of *Tensile Structures*, shortly available for \$18.50 from MIT is presumably equally good.

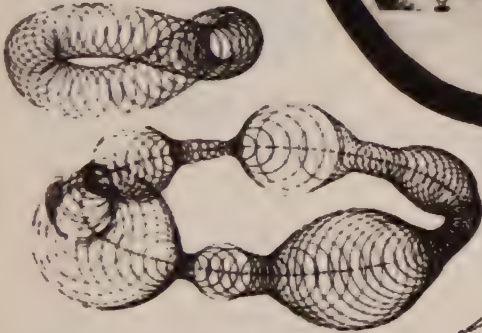
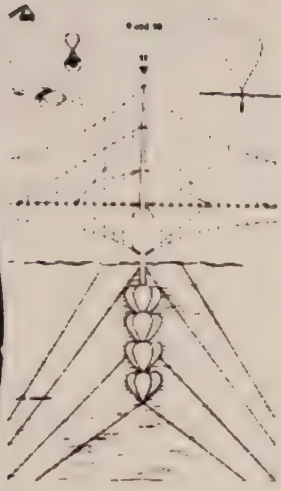
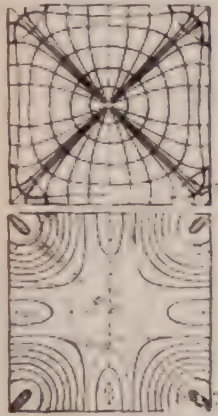

Tensile Structures Volume One
Pneumatic Structures

Frei Otto
1967; 320 pp.
1660 illustrations

\$22.50 postpaid

from:
The MIT Press
Cambridge, Mass 02142
or
EARTH CATALOG



The saddle surface of the inside part has a smaller area than the outside, which is not a saddle surface. The torus differs from all other pneumatically tensed membranes by this characteristically saddle-shaped region. The circle on which the spheres forming the torus are strung need not be in the same plane, nor need the spheres have equal diameter. Here, too, unlimited variations are possible, subject to the general laws of formation, and to those particular to closed hoses.

If two soap bubbles of different diameters form a twin bubble (Fig. 10), the diaphragm is curved. If the membrane stresses are equal, the gas pressure p in the smaller bubble is higher than that in the larger bubble. The relationship between the radii r_1, r_2, r_3 is given by:

$$n = \frac{p_1 r_1}{2} = \frac{p_2 r_2}{2} = \frac{(p_1 - p_2) r_3}{2}$$

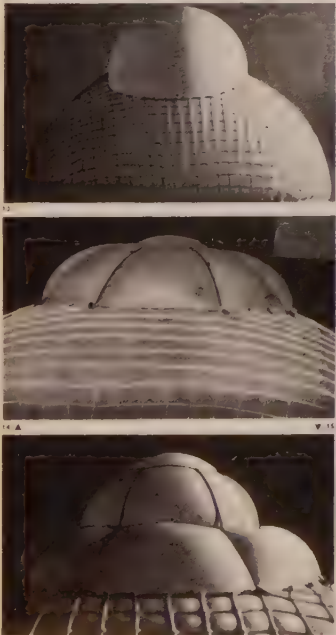

- A Membrane of heavy fabric or wire with transparent plastic coating.
- B Annular foundation.
- C Air inlet in air-conditioning tower having rotatable cap.
- D Guide-vane annulus to adjust position of cap.
- E Heat exchange in air-conditioning tower. In winter, the used air heats the fresh air in a counter-flow arrangement.
- F Blower
- G Air baffles

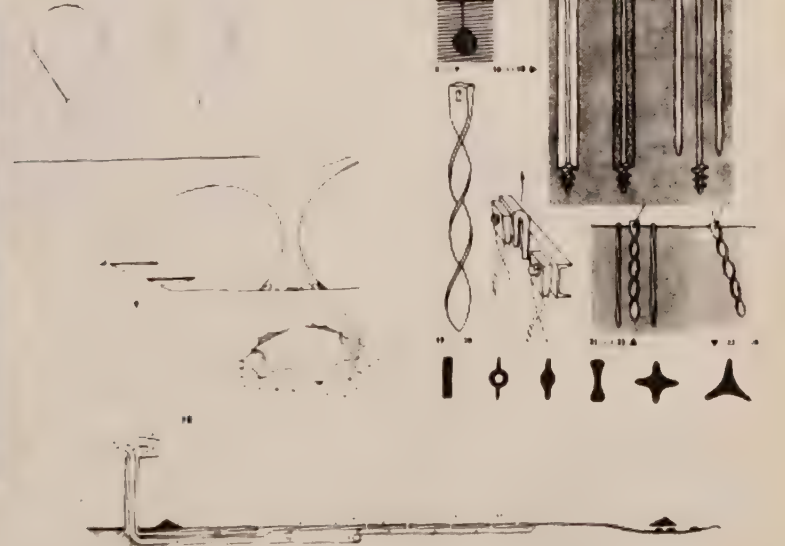

- H Heating and cooling plant.
- I Humidifier
- K Ring main.
- L Underground distribution line serves also to heat ground.
- M Warm air discharge
- N Used air extraction.
- O Pressure regulation valve.
- P Exhaust discharge.
- Q Air lock accessible to trucks.

Dome Cookbook

Drop City, Colorado, a rural vacant lot full of elegant funky domes and ditto people, has been well photographed and poorly reported in national magazines. Visitors and readers simply assumed that the domes were geodesic Fuller domes, which some indeed are. But most of them were designed by another guy who designed to another geometry: Steve Baer.

This tabloid contains the crystallographic theory and junkyard practice behind Baer's domes: from how to distort a polyhedron without affecting connector angles to how to chop the top out of a car without losing your foot. From all we can determine, Baer's theory is unique in architecture. So is his practice; instead of dying of dissertation dry rot, his notions stand around in the world bugging the citizens.

The Dome Cookbook is published by Lama Foundation, an intentional community in New Mexico, built largely of Baer domes.

When you are putting up a dome panel by panel you often have to use poles to support the wobbly sides as they close in toward the center. When we were putting up the second to last panel in the shop dome we had three poles in strategic spots to hold the wobbly overhanging panels from collapsing. The poles were nailed at the top so they wouldn't fall away if during a moment's strain the load were lifted up and off of them. The panel was an 8' x 19' and extremely heavy. We put it up with an inadequate crew, two men and two women. We struggled for an entire afternoon the last few inches Albert Maher pushed from on top of a spool resting on top of the cab of his pickup which we had driven into the dome. It was touch and go a clamp might slip, Albert might collapse, the poles might buckle. Each one of many failures seemed equally as probable as getting the monster joined to the neighboring panels. A huge shove, some quick work with the crow bar and clamps - Albert eased off and it still held, I took a few more turns on one clamp and added another one - it was a sure thing, we had it in place! It felt as if the panel had been lifted into place by some incredible wave we had created that now washed back as we put down tools and Albert got down off the cab. But there was one last thing to check - the poles, were they dangerously bowed under this new load. The entire sensation in my head began for a moment to turn inside out when Holly yelled "look at them" but then I saw what it

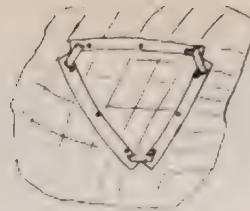

flexible plywood pattern on car top



panel cut and drilled

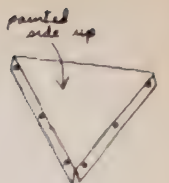

panel cut, drilled and broken

This is a wonderful quality of space, we can eat it up in different sizes and shapes in infinite numbers of ways.

If we adopt a family of angle regular or merely angle similar polygons to be used as floor plans of rooms, city blocks, etc. one further property we will almost certainly want is that the figures don't, as we place them side by side, have gaps appear, dead spaces which we can not occupy with any of our figures. It is likely that our plan will not be a dense packing, we ourselves will make gaps between the polygons, but we don't want their position imposed upon us!

shelter 15 \$/Land

from: ndation
 Ba: r
 Se: bal, New
 Me: '564

models - low cur-
 dule of semi reg-
 Cositer -
 Macmillan
 hese are
 good ill
 a differ
 A.O. al
 Polyeder
 Berlin
 complete
 great R
 Not yet
 English

Are we working at a new society- load sharing intelligently put together, one that will someday reveal the load bearing pillars of today's arrangement as totally unnecessary.

Will these pillars of society as they feel the structure trembling to lift up and away attach themselves hoping to hold it down, hoping to keep the status quo. Will that be a joke- something pretending to carry while being carried/?

low - Architectural Design

ales might
 many failures
 the getting
 the neigh-
 show, some
 row bar and
 off and it
 few more
 ad added
 a sure thing.
 panel had
 ce by some
 ad created
 as we put
 t got down
 ere was one
 - the poles,
 y bowed.
 The entire
 began for
 ide out
 .ook at them"
 it was-
 its shape,
 are heavy
 they were
 they had been
 top,
 re important
 in one moment
 slow swinging

Handwritten notes and diagrams about polyhedrons and domes. Includes sketches of a cube, a dodecahedron, and a dome structure. Text includes: "This is a cube and an exploded cube. You can see that rectangles appear over the edges and triangles over the corners." and "Here is an exploded cube showing that exploding a small cube or cutting away the edges and corners of a large cube can produce the same thing."

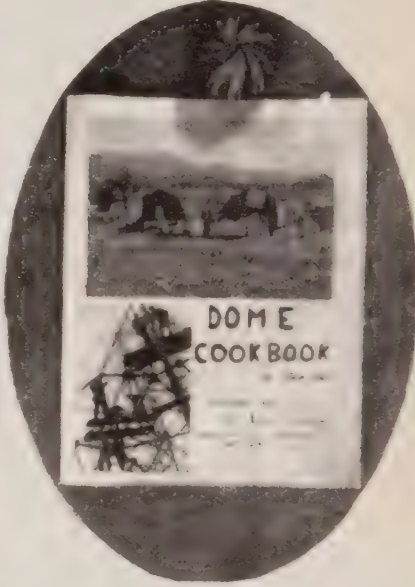

Good News

How many people do you know who got their grant? Edwin Schlossberg got his - from Rockefeller Brothers to put out a broadside of good news, six times a year, free of charge.

Schlossberg's appreciation of what is news and what is good is demonstrated by the contents of the current issue:

- 'The Future as a Way of Life' Alvin Toffler
- 'Education for Real' John McHale
- 'The Prospect for Humanity' R. Buckminster Fuller
- 'Diary: How to Improve the World (You Will Only Make Matters Worse)' John Cage
- 'Information Explosion-Knowledge Implosion' John McHale
- 'Logical Structure of Environment and its Internal Representation' Heinz von Foerster

[Why is this item not in Whole Systems? Partly oversight - partly that it's kindred to Baer.]

Good News from: Edwin Schlossberg 12 13th Street New York, N.Y. 10011

Free six issues this year

A highly sophisticated configuration is shown in Fig. 2c which presents the results of the first 200,000 steps of the motion of four spots each of which has the same constraints as our spots before, with the additional constraint that they all interact weakly with each other in the sense that they "repel" each other when they come too close (the transition probability for turning away from each other is slightly increased when near), and that they "attract" each other when they go too far (the transition probability for turning toward each other is increased when apart). Clockwise circumnavigated squares are painted black. Since there are only 256 steps visible in this pattern, it is clear that some of the steps must have been repeated several thousand times. Hence, this pattern has reasonable stability.



It is not difficult to show that with these types of connections, symbolized on an "idealized" neuron in Fig. 4b (namely excitation [yes], inhibition [no], or excitation [true], inhibition [false]) a single neuron is in a position to compute various "logical functions", and small nets of only three neurons are capable of computing all logical functions of the form "A and B", "A or B", "if A so B", "A equivalent B", "A or not B", etc. where A and B are two active afferent axons

A student of this structure, who does not know how it is created, will come to the conclusion that this "molecule" is built of two kinds of "atoms", one black (+) and one white (-), with shapes as suggested in Fig. 2d, which obey a law of nature that forces them to bind into higher structures such that opposite signs attract. We may smile at the naivete of this natural scientist who discovers these "laws", because we know that this whole pattern is generated by only four spots zooming around like mad in an almost random fashion. However, we should not forget that the accent lies on the almost. That is the crux of my thesis: Small constraints are sufficient to produce considerably ordered structures. Hence, the discoveries of our natural scientist are not so naive after all; he only puts his knowledge into a different language. The two descriptions are equivalent.

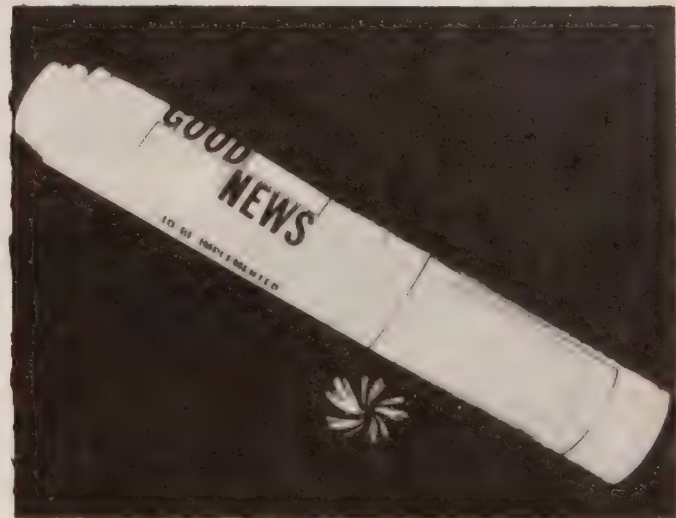

Heinz von Foerster

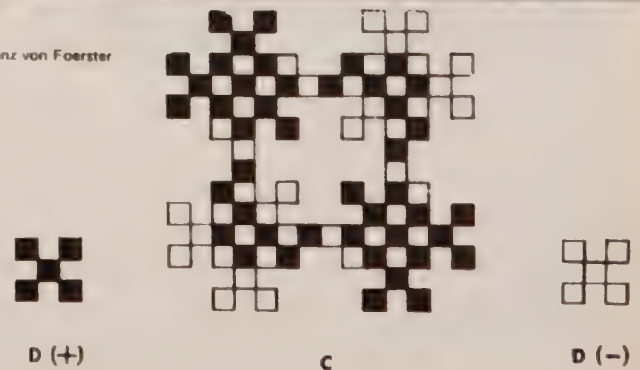

Architectural Design

This is the only architectural magazine we've seen that consistently carries substantial new information, as distinct from the stylistic eye-wash characteristic of most architecture journals. It galls my jingoistic soul to see the British publishing so much of the best technological information (cf. New Scientist, p.24; Industrial Design, p.25; Sculptor's Manual, p.30; TV Production, p. 39). Dave Evans, a local Australian whiz, says it's because English bright guys don't have much to grip them commercially, so they spread their brightness around. (Also they flock to America in search of commercial ferocity.)

Anyway, here's to more fluid information.



Architectural Design
\$15.50 postpaid
 for one year (monthly)
 from
 Architectural Design
 2100 S. Main Street
 Leicester, MA 01545

Triggered by a lack of space, and wanting to do something, a group of architectural students at MIT last year spontaneously rebelled against the constraining environment of their drafting rooms. Scrounging materials, working clandestinely, they shifted block partitions and erected a series of mezzanines or platforms within their two-storey drafting rooms (centre). Three architecture students, Stern, Hanks and Owen, describe below the process as they saw it. The design faculty, also cramped for space, solved their own problems more conventionally, through outside designers and contractors. This failed to generate a corresponding level of excitement, commitment or sense of achievement.

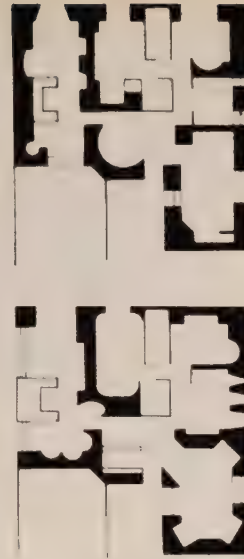

Capsized freak out
 Metal to rubber of asphalt ribbons plugged into Vietnam and the price of aerosolled ketchup thru W.D.B.J. Star City via the chromium telescoping finger. 700 miles of the great highway turn on, 13 hours of keen-sell survival service and all the gear to keep the wheels flying, the gut full, and the mind blown on soul and acid, and tune-in, cat, and flash, rush, One South and zapp it forward, gas-up; and hum and sink into supra-fit vinyl pads and watch it all. All the cardboard cities and the X-ray of us all on the gunt billboards. And buy me, lay me hot dog-burgers. Blink, zip me into bed and flash past a thousand Kleenex sleepies and King-size pleas trying to break up the big high and consume hy-flyte, Pep-up, an alligator breakfast a nude-serviced cat.

The Japanese House

Without getting all sentimental and exotic we're still going to agree that Japanese make better houses than anybody else (they also have the fastest growing economy in the world, but that's another story - or is it?). If you're going to build your own house and don't mind some inspiration on the subject, this book was laboriously made for you. It's a great big Christmas present of a book full of yummy photos and diagrams and details of technique, all of which seems right within reach: I-can-do-it. Nice cure for nothing-can-be-done-because-it's-too-damned-big industrial blues.

[Suggested by Tassajara Zen Center]

\$27.50 may choke you up in which case try Japanese Homes and Their Surroundings, \$2.50 from Dover Publications, Inc., 180 Varick Street, New York, N.Y. 10014

SECLUSION IN BUILDING is an essential instrument for establishing, or preserving, the freedom of man. For, only in solitude can man escape from the coercion to which he is subjected when among the masses.

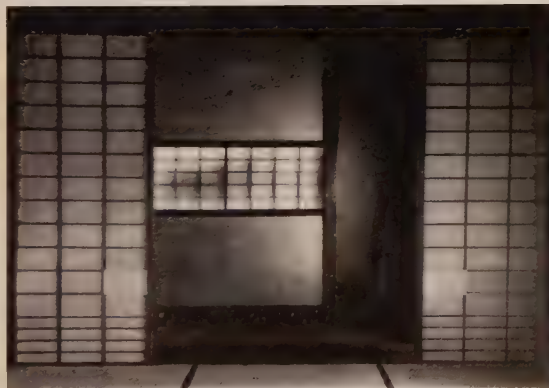
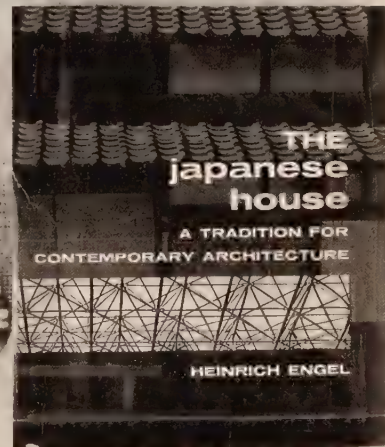

Shoji paper is the "glass" of the Japanese house. Its qualities, however are of a different nature, and thus, also are its effects. The light, broken already by the broad overhand of the eaves, is diffused by the paper and creates a characteristic light condition comparable to twilight. This situation does not change basically even if the evening or winter sun hits the paper directly. No glare, no shadows; a general gloom creates a soft, emotional atmosphere. With artificial light in use, the shoji paper shows its reflective-diffusing ability, and at night with lights turned out, might even offer an interesting shadow play the moon has staged with the old weather-worn pine tree. As time passes, the paper darkens. Here and there, a torn piece is carefully cut out and replaced by new, lighter paper. The paper pattern becomes, though irregular, more interesting and lively. The paper ages, as does man.



The Japanese House - A Tradition for Contemporary Architecture

Heinrich Engel
 1964; 495 pp.
\$27.50 postpaid

from: E Tuttle Co; Inc.
 100 South Main Street
 Waterbury, Vermont 05701
 or: THE EARTH CATALOG

Once the room requirement is decided, the separate rooms are sometimes cut out in paper and children and parents individually try to achieve the best room arrangement on the ken grid. One mat arrangement is finally decided upon and wall openings, picture recesses (tokonoma), closets, etc. are listed. No measurements are given. Everything is controlled merely by the ken grid and the mat arrangement.

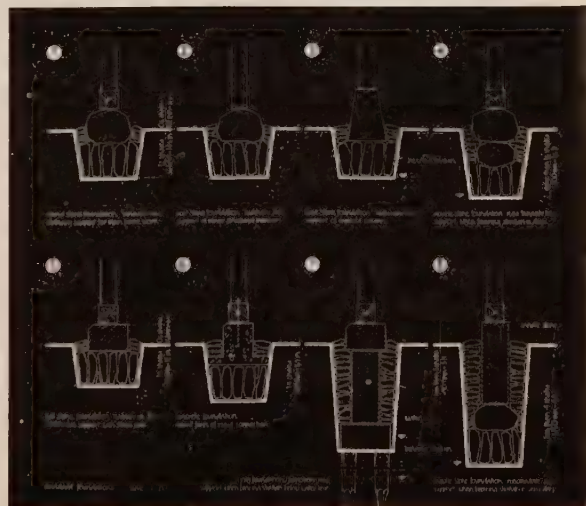

Audel Guides

We've seen no series of individual technique publications more complete than the Audel books published by Howard Sams and Company. However, we're not proficient enough in this area to critique particular manuals against others in their field. *Suggestions and reviews invited.*

This part of the **WHOLE EARTH CATALOG** should be one



All the following prices are postpaid.

- Automobile Guide (AUD-1) \$6.95
- Home Appliance Service Guide (AUD-2) \$6.95
- Radiomans Guide (AUD-3A) \$5
- Television Service Manual (AUD-3B) \$5
- Handy Book of Practical Electricity (AUD-4) \$5.95
- Truck and Tractor Guide (AUD-5) \$5.95
- Plumbers & Steam Fitters Guides - 4 Vols. (AUD-6)
- Painting & Decorating Manual (AUD-7) \$4.95
- Carpenters and Builders Guides - 4 Vols. (AUD-8) set \$16.95
- Diesel Engine Manual (AUD-9) \$6
- Welders Guide (AUD-10) \$4.95
- Mathematics and Calculations for Mechanics (AUD-11) \$4.95
- Machinists Library (AUD-12) \$13.50 set
- Wiring Diagrams for Light and Power (AUD-13) \$4
- Home Refrigeration & Air Conditioning Guide (AUD-14A) \$6.95
- New Electric Library 10 Vols. (AUD-15A) set \$25
- Answers on Blueprint Reading (AUD-25) \$4.95
- Masons & Builders Guides - 4 Vols. (AUD-26) set \$10.50
- Electric Motor Guide (AUD-27) \$5.95
- Oil Burner Guide (AUD-28) \$3.95
- Sheet Metal Pattern Layouts (AUD-29) \$7.50
- Sheet Metal Workers Handy Book (AUD-30) \$3.95
- Mechanical Drawing Guide (AUD-31) \$3
- Mechanical Drawing and Design (AUD-32) \$3.95
- Questions & Answers for Electricians Exams (AUD-34) \$3.50
- Electrical Power Calculations (AUD-35) \$3.95
- New Electric Science Dictionary (AUD-36) \$3.50
- Power Plant Engineers Guide (AUD-37) \$6.95

Alaskan mill

We've heard almost nothing about how good this 'one-man sawmill' is, but we've heard plenty of statements of need for such an item. If you get one before we do, let us know about it.

The ALASKAN JR. is a lightweight, one-man lumbermaker. Drill 3 holes in the blade and simply mount on your chain saw. It is easy to operate, and mills accurate smooth, full dimension grade one lumber-wherever you need it, even in remote areas.

SIMPLY MOUNT THIS ATTACHMENT TO YOUR CHAINSAW MOTOR. . . . no special tools or alterations are required. It's as simple as changing bar and chain. Use with one or two motors, either direct or gear drive with 6 or more horsepower. With this attachment you can make all the lumber you need. All perfectly dimensioned beams, railroad ties, cabin logs, hardwood cants, etc. The Alaskan is available in 6 models.

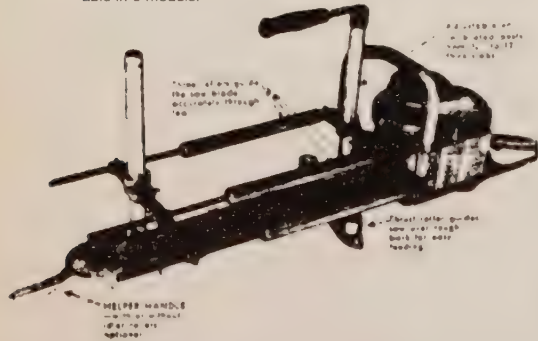

Alaskan, Jr. for blades 16"-24" 20 lbs. **\$57.00**

postpaid for complete unit: Alaskan, Jr., bar and chain, helper handle, oiler kit, guide rail brackets, file and guide, and 7 hp Mono power unit. **\$333.58**
Complete Alaskan (minus engine) for logs to 20"

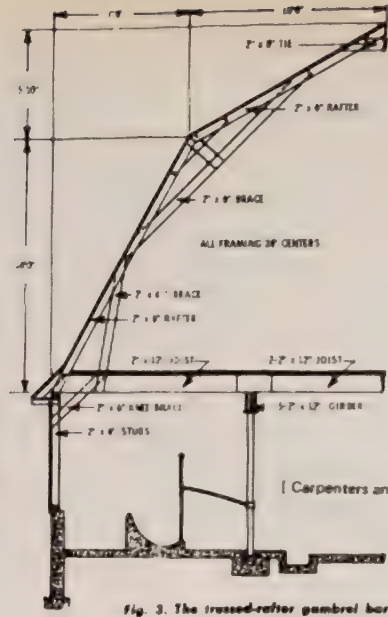
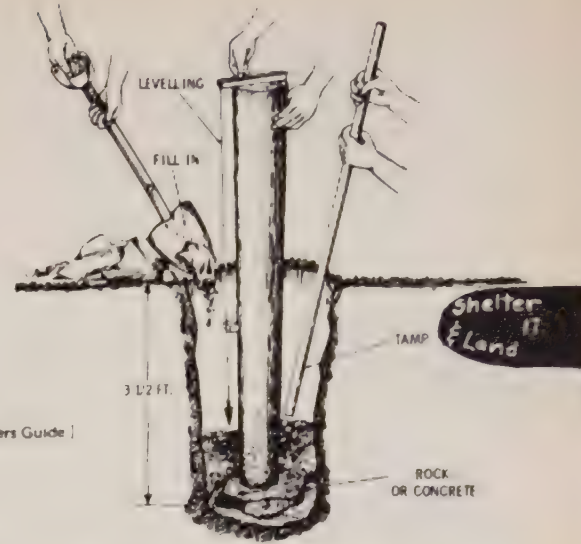

Fig. 3. The trussed-roof gambrel barn roof.

- Questions & Answers for Engineers & Firemans Exams (AUD-38) \$4
- Pumps, Hydraulics, Air Compressors (AUD-40) \$6.95
- House Heating Guide (AUD-41) \$5.95
- Millwrights & Mechanics Guide (AUD-42) \$6.95
- Do-It-Yourself Encyclopedia 2 Vols. (AUD-43) \$8.95
- Water Supply & Sewage Disposal Guide (AUD-46) \$4
- Gas Engine Manual (AUD-48) \$4
- Outboard Motor & Boating Guide (AUD-49) \$4
- Encyclopedia of Space Science - 4 Vols. (AUD-50) set \$19.95
- Domestic Compact Auto Repair Manual (AUD-52) \$5.95
- Foreign Auto Repair Manual (AUD-53) \$5
- Programmed Basic Electricity Course (AUD-54) \$4
- Home Workshop & Tool Handy Book (AUD-55) \$5
- Home Modernizing & Repair Guide (AUD-56) \$2.95
- Practical Chemistry for Everyone (AUD-57) \$5.95
- Home Gas Heating and Appliance Manual (AUD-59) \$3.50
- Practical Guide to Mechanics (AUD-61) \$4
- Practical Mathematics for Everyone - 2 Vols. (AUD-66) \$8.95
- Architects and Builders Guide (AUD-69) \$4
- Handbook of Commercial Sound Installations (AUD-92) \$5.95
- Practical Guide to Tape Recorders (AUD-93) \$4.95
- Practical Guide to Auto Radio Repair (AUD-94) \$4.50
- Practical Guide to Citizens Band Radio (AUD-95) \$4.95
- Practical Electronics Projects for the Beginner (AUD-96) \$4.95
- Practical Guide to Servicing Electric Organs (AUD-97) \$4.95
- Practical Guide to Building Maintenance (AUD-99) \$4.95
- Practical Guide to Fluid Power (AUD-100) \$6.95
- Practical Science Projects in Electricity/Electronics (AUD-102) \$4.95

Foundations



1. A method of erecting a post. Note the large rock or concrete at bottom of the hole. The post is leveled from all angles with a slumb bar.

for
Th
al & Company
43
62nd Street
Inda
is, Indiana 46206

Fastening Tools

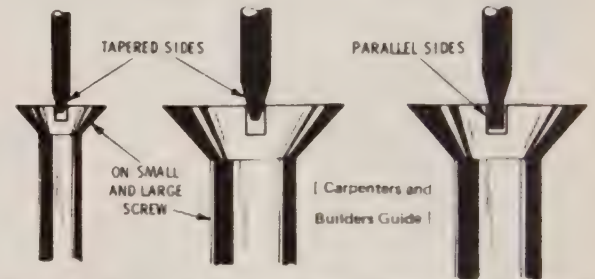
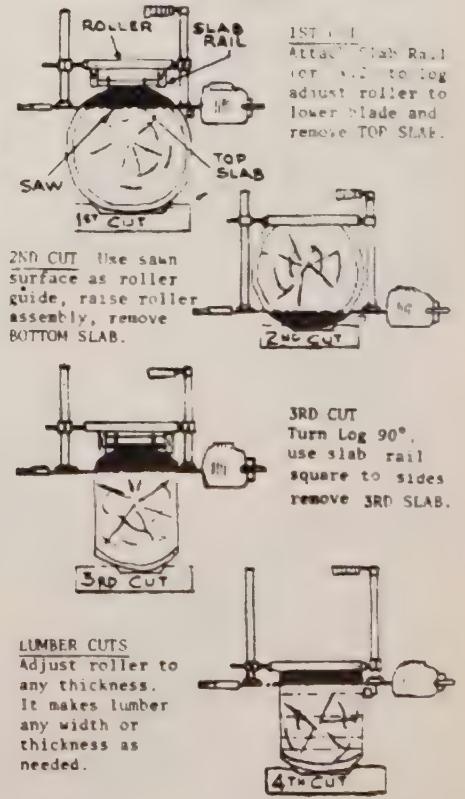

Fig. 7. The end of a screwdriver should be shaped so that its sides are parallel. A screwdriver whose end is tapered can be used, but considerable downward pressure must be exerted to prevent the screwdriver from rising out of the screw slot. With parallel sides, there is no tendency for the screwdriver to rise, no matter how much turning force is exerted.

IT'S EASY
TO MAKE LUMBER WITH THE ALASKAN
HERE IS HOW!



1ST CUT Attach Slab Rail
iron roller to log
adjust roller to
lower blade and
remove TOP SLAB.

2ND CUT Use saw
surface as roller
guide, raise roller
assembly, remove
BOTTOM SLAB.

3RD CUT
Turn Log 90°
use slab rail
square to sides
remove 3RD SLAB.

LUMBER CUTS
Adjust roller to
any thickness.
It makes lumber
any width or
thickness as
needed.

42 lbs. (other sizes available). **\$267.50**
postpaid for complete Alaskan, with 9 hp Mono power unit **\$419.95**

Alaskan mill
for
K
P
H

Village Technology

VITA (Volunteers for International Technical Assistance) is the only source of specific practical information on small-group technology that we've found. But what a source. They have prepared a two-volume "Village Technology Handbook" for overseas use by the U.S. Agency for International Development that is ideal for rural intentional communities. This handbook now is in revision; the new edition should be available as of December, 1968 - inquire for price.

Also VITA has a catalog of funky tools - Village Technology Center Catalog - available free. For the items listed they will supply plans for making the tools, or rent or sell the items - inquire for price.

VITA has a series of specific papers that cost very little (eg. 30¢). Titles include "Low-Cost Development of Small Water-Power Sites", "How to Salt Fish", "Making Building Blocks with CINVA-Ram", "Solar Cooker Construction Manual".

WOVEN OR WATTLE CONSTRUCTION

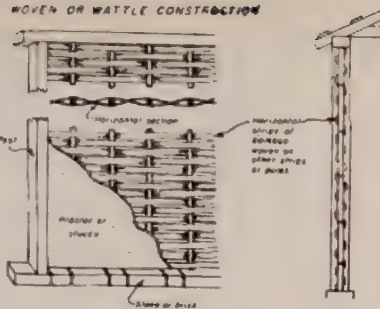

Equipment for which suitable designs are being sought or developed for inclusion in future catalog supplements:

- | | |
|-----------------------------|-----------------------------------|
| 1 Animal harness | 28 Clothes wringer |
| 2 Tractors | 29 Chlorinator |
| 3 Moldboard plows | 30 Sterilizer |
| 4 Harrows | 31 Baby incubator |
| 5 Seed planters | 32 Baby scales |
| 6 Grain drills | 33 Automatic flush toilet |
| 7 Cultivators | 34 Solar food dryer |
| 8 Dusters | 35 Solar still |
| 9 Sprayers | 36 Soil mixer |
| 10 Threshing machines | 37 Sifting apparatus |
| 11 Winnowing machines | 38 Concrete mixer |
| 12 Seed cleaner | 39 Concrete block machine |
| 13 Rice huller and polisher | 40 Concrete block forms, wood |
| 14 Oil seed press | 41 Wheelbarrows |
| 15 Farm cart | 42 Flashlight projector |
| 16 Rice drying equipment | 43 Photo enlarger |
| 17 Incubators | 44 Bamboo science equipment |
| 18 Brooders | 45 Playground equipment |
| 19 Peanut sheller | 46 Arc welder |
| 20 Pumps | 47 Spot welder |
| 21 Deep well pump | 48 Blacksmith's forge |
| 22 Rotary centrifugal pump | 49 Sheet metal brake |
| 23 Diaphragm pump | 50 Sheet metal rolls |
| 24 Hydraulic ram | 51 Kiln |
| 25 Well drilling equipment | 52 Potter's wheel |
| 26 Well casing forms | 53 Bobbin winders |
| 27 Sawdust heating stove | 54 Spinning and weaving equipment |



Outdoor storage pit.

Se
VIT
Cc
Sc
impus
y, N.Y. 12308

Shelter
is
Land



SOLAR WATER HEATER

ABSTRACT

To provide hot water, primarily for washing clothes, in areas where fuel is scarce and sunshine is plentiful.

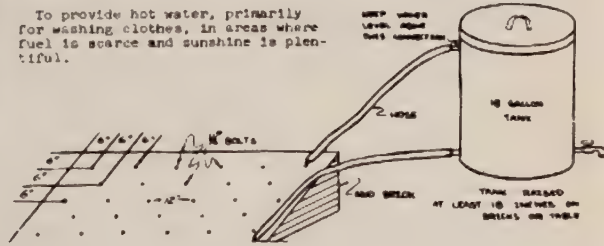
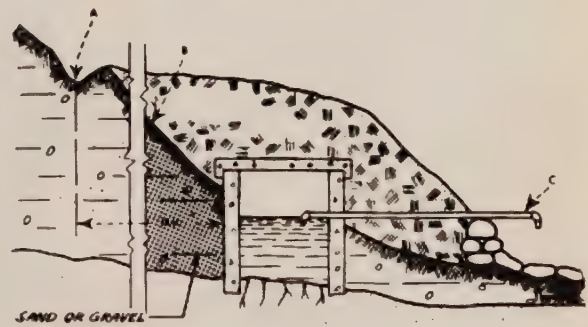

Fig. 33. PROPERLY PROTECTED SPRING (I)



- A Protective drainage ditch to keep drainage water a safe distance from spring
- B Original slope and ground line
- C Screened outlet pipe can discharge freely or be piped to village or residence

"BEEHIVE" BUILDING

Cat. No. M-103

The "BEEHIVE" BUILDING, so named because of its shape, is unusually well adapted for use as farm out-buildings (chicken houses, storage sheds and granaries). It is cheap to build because the walls are only 25 cm thick and come together to form the roof. Sun-dried bricks are suitable construction material in dry areas; stabilized earth or burned brick plus a covering of water-proof plaster must be used in areas with high rainfall.

Building instructions only

CONSTRUCTION JIG for "BEEHIVE" BUILDING

Cat. No. M-103A

The construction of the "BEEHIVE" BUILDING is simple and can be done by unskilled people using the JIG shown. The JIG is designed to swing completely around while the free end serves as a guide pole. By laying the bricks against the end of the guide pole, the building is kept perfectly circular and the walls are brought in to form the "beehive" shape. Base and fitting only; poles must be provided locally.

Diameter: 3' - Length: 36" Wt. 30 lbs.

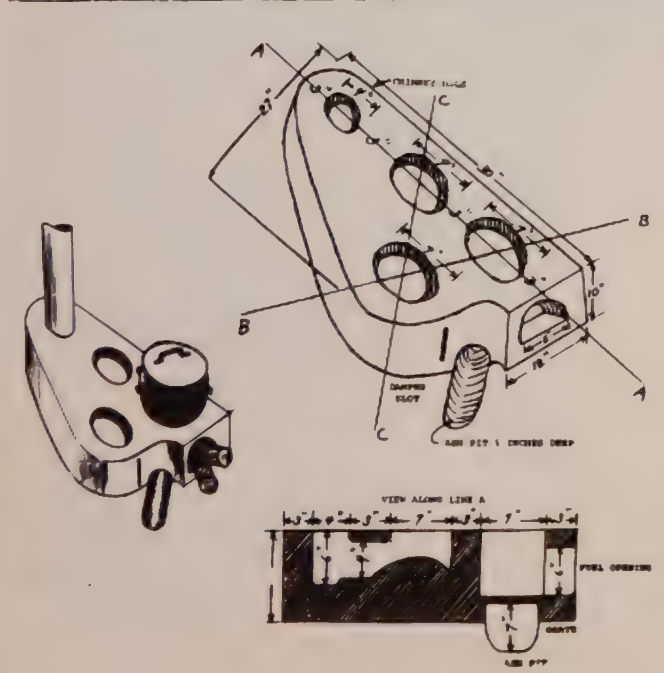

WOODMAKER'S CUTTING BENCH

Cat No. M-114

This ingenious CUTTING BENCH has a vise at one end in which a block of wood could be held by pressing on a foot treadle--leaving both hands free to operate tools. It is a very useful device which has application in a number of situations. One of its earlier uses was for holding wooden shingles while tapering with a draw-knife.

Size: 20"x72"x42" Wt. 100 lbs.

EVAPORATIVE FOOD COOLER

Cat. No. M-83

In warm and dry climates, an EVAPORATIVE FOOD COOLER will extend the period for keeping food fresh and preserve leftovers. It also helps to keep crawling and flying insects away from food. The COOLER operates on the principle of evaporation of water from the heavy cloth cover which is kept wet at all times by absorbing water from the pan in which the cooler stands. It will not work in damp and humid areas.

Size: 17"x13"x57" Wt. 26 lbs.

VITA SOLAR COOKER

Cat. No. M-73

The VITA SOLAR COOKER is designed to be sturdy, relatively easy to make, easy to repair and low in cost. It uses the principle of the Fresnel reflector which concentrates light and heat. The COOKER--when used in areas having more than 2000 hours of sunshine per year--provides the heat equivalent to 500 watts (which will boil a quart of water in 12 to 15 minutes). Larger models of the COOKER can be provided.

Size: 52"x46"x50" Wt. 24 lbs.

The Indian Tipi

Tipis are cheap and portable. To live in one involves intimate familiarity with fire, earth, sky, and roundness. The canvas is a shadow-play of branches by day, people by night. Depending on your body's attitude about weather, a tipi as a dwelling is either a delight or a nuisance. Whichever, you can appreciate the elegant design of a tipi and the completeness of the culture that produced it.

The Laubin's book is the only one on tipis, but it is very good. All the information you need, technical or traditional, is here, and the Laubins are interesting people.

Later we discovered that the idea of a ventilating pipe underground to the fireplace is the very best way of insuring a clear lodge and the most heat.

It is a joy to be alive on days like this, and when we come back to the tipi, after a long ride or a hike in the mountains, the little fire is more cozy and cheerful than ever. The moon rides high in the late fall nights, and when it is full, shines right down through the smoke hole. Its pale white light on the tipi furnishings, added to the rosy glow of the dying fire, is beautiful beyond description.

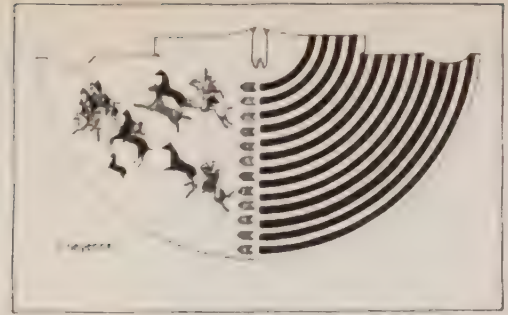

shelter & Land

Indians had definite rules of etiquette for life in the tipi. If the door was open, friends usually walked right in. If the door was closed, they called out or rattled the door covering and awaited an invitation to enter. A shy person might just cough to let those inside know he was waiting. If two sticks were crossed over the door, it meant that the owners either were away or desired no company. If they went away, they first closed the smoke flaps by lapping or crossing them over the smoke hold. The door cover was tied down securely and two sticks were crossed over it. The door was thus "locked," and as safe in Indian society as the most strongly bolted door would be in our civilization today.

The Indian way of attaching peg loops, as illustrated, is not only ingenious but easy and sturdy - far better than either sewn or stamped grommets. Insert a pebble about 3/4 of an inch in size on the under side of the cover about six inches above the edge, at a seam wherever possible, and around this pebble tie a piece of 3/15-inch cord. Double the cord, tie it in either a square knot or a clove hitch about the pebble, then join the free ends in a square knot. Marbles will do if you cannot find smooth round pebbles.

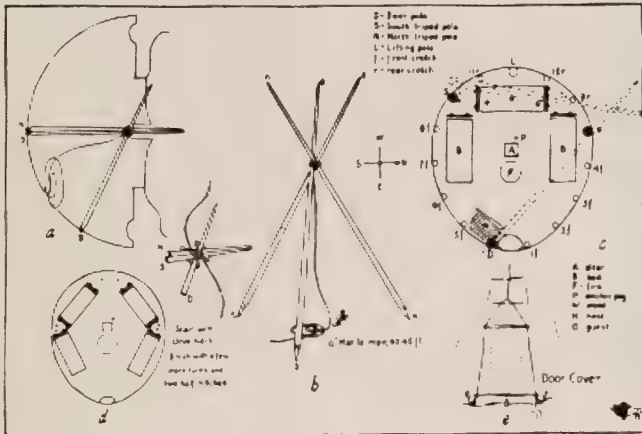

Fig. 3. Erecting the Sioux Tipi

The Indian Tipi
Reginald and Gladys Laubin
1957; 208 pp.

\$4.95 postpaid

from:
University of Oklahoma Press
Sales Office
Folk Exchange
Norman, Okla. 73069
or
WORLD EARTH CATALOG

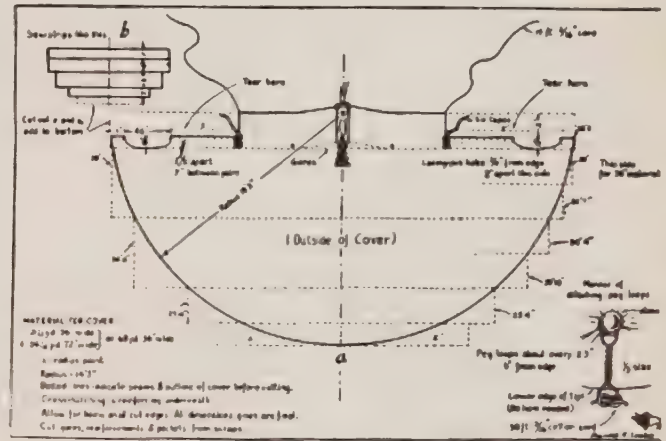

Fig. 1. Pattern for Sioux Tipi (18-foot)

Tipis

We have word about three sources in the U.S. of ready-made tipis, and so far Goodwin-Cole is still the best - best construction, lowest cost. They also have tipi liners, which you will need if weather is wet or cold.

For the following, shipping weights are undetermined. Inquire, or have the item sent shipping cost C.O.D.

	10 oz. white duck	10 oz. flame treated white duck
10' diameter	\$55	\$83
14' diameter	\$66	\$98
20' diameter	\$108	\$154

10-foot is suitable for nomadic couple; 14-foot for small family. 20-foot for extended family or occasions. Flame-treated is unpleasant; law requires it in some places. Tipis of green, blue, orange, red or yellow drill are available. Poles are available if you're that lazy.

from:
Goodwin-Cole Company
11111 Ambra Blvd.
Escondido, California 95816



Aladdin Kerosene Lamps

Coleman lamps are terrible - they hiss and clank and blind you, just like civilization.

Aladdin is the answer if you need good light and 117ac isn't around. It is bright, silent, and requires no pumping. (It does require some babying to keep the mantle from smoking up; it's like not burning toast.)

British made and efficiently designed, the lamps are available in this country from:

Aladdin Industries, Inc.
Kerosene Lamp Division
Nashville, Tennessee 37210

Some of the Aladdins are rather ornamental. The simplest designs are B-139 Font Lamp (aluminum) \$15.97

and B-223 Hanging Lamp \$22.63 (shade extra: \$2.60)
C.O.D. the shipping costs.

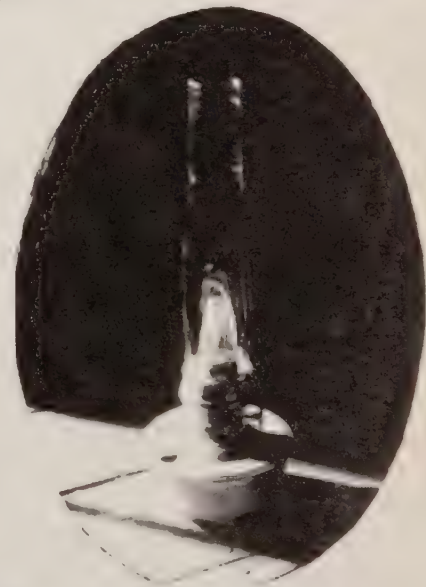

Man's Role in Changing the Face of the Earth

This book of almost 1200 pages is the result of a major conference held in 1955, sponsored by the Wenner Gren Foundation for Anthropological Research. More than 50 scholars submitted papers, covering almost every imaginable point of view related to man's capacity to transform his physical environment. Though first presented nearly 15 years ago, the facts and insights are richly rewarding today. In my opinion in fact, it is an unsurpassed achievement in assembling pertinent, insightful information of interest not only to serious students of the planet Earth, but to non-trained readers as well.

The three sections of the book are: I. "Retrospect", an historical background; II. "Process", methods and agencies involved in man's interactions with the land; and III. "Prospect", the effects and future implications of man's habitation of the Earth. Some typical subjects covered within these sections include: fire as the great force employed by man; origins and decline of woodlands; man and grass (sic); ecology of peasant life; harvests of the seas; ports channels and coast lines; and sewerage (don't belittle sewerage - society is structured around it).

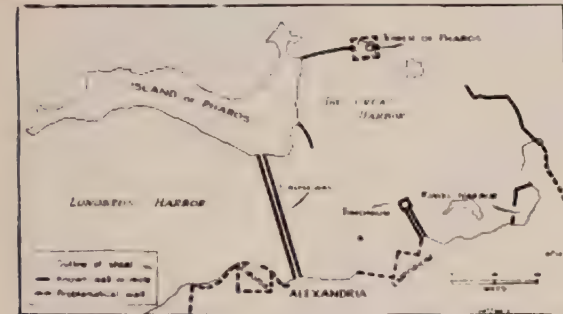

This book rewards a reader like me because of its minimum of moralizing and its abundant substance. Edgar Anderson, director of the Missouri Botanical Garden in St. Louis and without whom such a book as this would be certainly incomplete, pointed out that the average thoughtful person has little inkling of how man has reclothed the world. Even professional biologists have been tardy in recognizing that a significant portion of the plants and animals surrounding us are of our own making. For example, neither Kentucky bluegrass nor Canada bluegrass is native to those places, but came from Europe. The corn belt is a very obviously man-dominated landscape, but the casual observer might never realize that even the grass covered and oak-dotted stretches of what looks like indigenous California vegetation came uninvited from the Old World along with the Spaniards.

(Reviewed by Richard Raymond)

Generally speaking, the plants which follow man around the world might be said to do so, not because they relish what man has done to the environment, but because they can stand it and most other plants cannot.



The 17th and 18th centuries were a time of creating new plants. From 1600 to 1800 the European world was dominated by the Dutch. The Dutch were the first to plant the deadwood forest of a home stream, now a dead stream. The Dutch were an English lawyer that the surrounding country. The Dutch were the first to plant the deadwood forest of a home stream, now a dead stream. The Dutch were an English lawyer that the surrounding country. The Dutch were the first to plant the deadwood forest of a home stream, now a dead stream. The Dutch were an English lawyer that the surrounding country.



Courtesy of John B. ...

Almost every change in environmental conditions which man can make results in some change in the water economy or water budget at the earth's surface.

The pressure for beef supply from the grasslands is very rapidly depleting the potential for protein. Where the plow went ahead

of the cow, we have been able to measure the reduction in soil capabilities. The protein content of the wheat now grown on the eastern edge of the grassland area has been dropping decidedly. Where once it ranged from 19 to 11 per cent, it is now 14-9 per cent.

These are all very good ideas, but I've got something else that is very much more important. Every time you get where there is one of these populations of plants, find a large, flat rock, in the shade if necessary; sit down upon it for a least fifteen minutes by your wrist watch; and do not try to think about your clematises. Just think what a nice day it is, how pretty the flowers are, and the blue sky. Think how lucky you are to be doing this kind of work when the rest of the world is doing all the awful things they do not want to do. Just let your mind alone. Now, I am not joking. Please do this, by the clock if necessary.

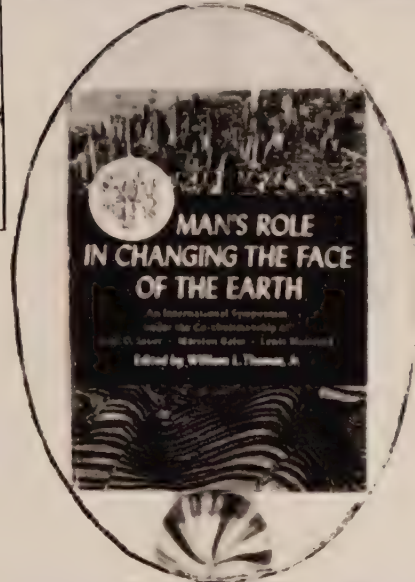

Man's Role in Changing the Face of the Earth

William L. Thomas, ed. 1956; 1193 pp.

\$15.00 postpaid

from: University of Chicago Press 1100 South Langley Ave. Chicago, Illinois 60628 or WILSON EARTH CATALOG

Two Mushroom Books

Finding a strange, slimy, luminous colored growth on dark rotting wood is surprise and pleasure; to extend that experience into identifying it and possibly EATING it is even better. For the beginner one batch of mushrooms can occupy a whole day, from finding them, through waiting for a good spore deposit and making a decision, to cooking them. An efficient guidebook is essential to avoid frustrations.

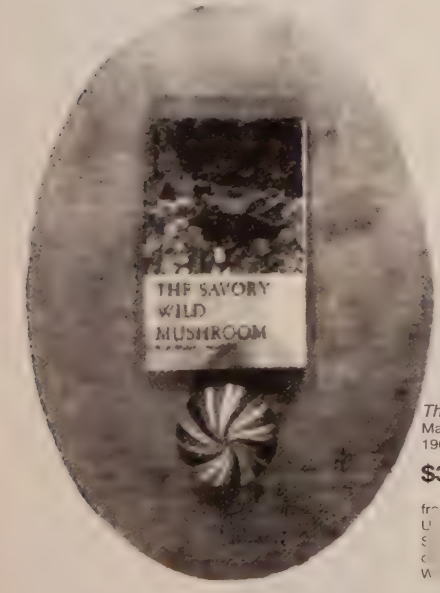

The Mushroom Hunter's Alexander H. Smith 1958; 1967; 264 pp. \$6.95 postpaid

from: University of Michigan Press 600 University of Michigan 4810 C WILSON EARTH CATALOG

The Savory Wild Mushroom Margaret McKenny 1962; 133 pp. \$3.95 postpaid

from: University of Washington Press 500 University of Washington 98105 C WILSON EARTH CATALOG

On a tramp through the fields and forests, carry with you a small jar of butter, creamed with salt and pepper. On finding any edible mushroom (except morels or elfinsaddles), collect a few dry sticks and fire them. Split a green stick (alder or willow) at one end. Put the mushroom in the cleft, hold it over the fire until tender, season with the butter. Eat from the stick.

from "The Savory Wild Mushroom"

The McKenny book is compact, but not especially well organized for use. It contains clear and concise descriptions of 83 varieties of fungi, some of them peculiar to the Puget Sound region, the rest common throughout the U.S., and 33 black-and-white and 48 color photographs. There is also an article on mushroom poisons and the many fine recipes make one want to rush to the woods and immediately gather baskets of Chanterelles, Morels and Ceps. Not so easy!

Smith's book, which I prefer, is more technical in language and scope, although, as a field guide, it avoids identification methods involving microscopes and chemicals. It is much more complete, covering 188 varieties with a black-and-white photo of each plus 84 color photos, and it is organized in keys which are super to use if you like being methodical. It is not necessarily true, however, that it is quicker to follow the system: in thumbing through either book, as in wandering in the woods, luck and perseverance further.

(Suggested and reviewed by Sandra Tcherepnin)

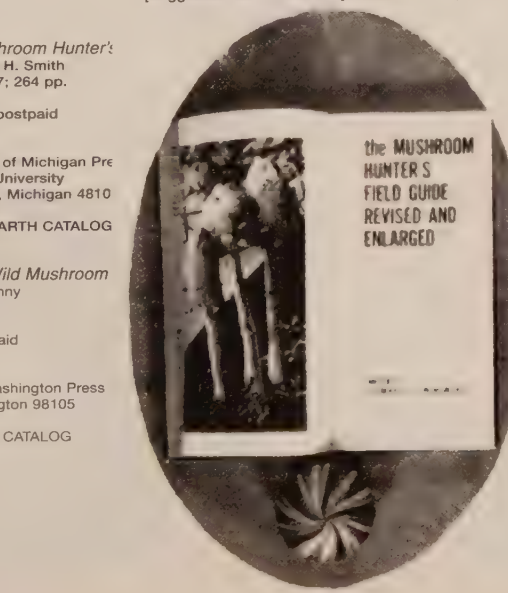

164. COPRINUS ATRAMENTARIUS (INKY CAP) Edibility. Edible, but some people experience a peculiar type of intoxication from eating this species and afterward drinking an alcoholic beverage. I have now discovered three people in Michigan with this type of sensitivity. from "The Mushroom Hunter's Field Guide"

KEYS TO FAMILIES

1. Gills turning black and "melting" at maturity
Coprinus, in the family Coprinaceae
1. Gills not liquefying at maturity
2. Gills free from the stalk
2. Gills attached to the stalk
3. Spore deposit chocolate brown to blackish and mature gills the same color
3. Spore deposit and mature gills paler
4. Spore deposit pink to vinaceous or reddish; mature gills about the same color
4. Spore deposit white (greenish in one)
5. Volva present around base of stalk or remains of outer veil present on the cap
5. Volva absent, inner veil present, cap if scaly with the scales ingrown and usually of appressed hairs (fibrillose)
6. Spore deposit white to pale lilac, yellow, or pinkish buff

from "The Mushroom Hunter's Field Guide"

Organic Gardening

How to Grow Vegetables and Fruits by the Organic Method

In the month that I have had my copy of "How to Grow Vegetables and Fruits by the Organic Method," I have browsed it and referred to it for so many different reasons, out of so many different moods, that I can't decide if its resting place on the shelf is among my other "how-to" books or somewhere between the poetry and books on oriental religion.

But I shall worry about that problem when the time comes, if it does. Right now I'm digging into it so often and with such delight it doesn't need a place on a shelf. I keep it in handy reach on the dining room table.

This book is the definitive manual on organic gardening. It is loaded with information, 550,000 words spread over 926 pages. It is wonderfully illustrated with pictures that are precise and useful, as well as pleasing to the eye. In a pleasant, relaxed prose style, the style of people who obviously have spent more time in the garden than in the library but who at the same time are so confident of what they're saying their words ring hard and true, the editors of this manual have gathered together every fact that one would need to know to become a successful organic gardener, almost anywhere in the United States.

Vitamin Losses

Vegetables to be cooked should be handled in the same manner as salad vegetables. Gather immediately before using or else wash, dry and store in a cool place. If they are left at room temperature and in the light, much folic acid, vitamin B₂ and 50 per cent or more of the vitamin C in most fresh vegetables can be lost in a few hours.

Inoculate Garden Legumes

If you are planning to grow any beans, peas or peanuts in your garden this spring, why not take time out to inoculate the seed with nitrogen-gathering bacteria? It will certainly be worth your while.

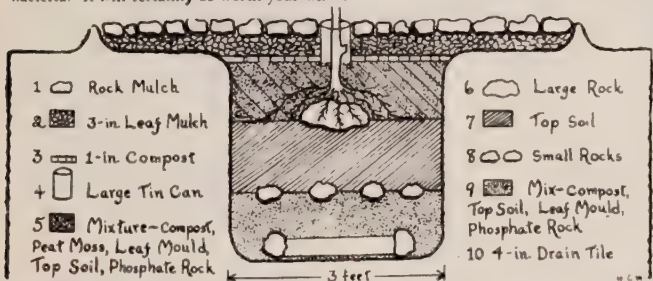

This book has another quality one does not always find in gardening manuals: it is well organized. The first part is about the soil; the second part is about vegetables, the third part is about fruit, and the closing pages are devoted to nut culture and herbs.

In Section one, there are chapters on how to improve the soil; make compost; start plants from seed; watering and irrigation; when to harvest; fall and winter gardening; controlling insects; greenhouse gardening.

Section two looks closely at some 100 vegetables, giving a page to each vegetable, artichokes through zucchini, and what amounts to a brief essay that describes the history, vitamin content and how to raise each individual vegetable.

Another section does the same with some sixty varieties of North American fruit, from apples and apricots to water-melons and youngberries.

In addition, there are scores of charts and graphs that provide a complete planting guide for all the listed vegetables and fruits. Each geographical region of the United States and its peculiarities are accounted for. One table, for instance, is titled, "Planning Guide for a Family of Five in Washington." Categories of information for gardening in Washington include planting dates, growing period, length of the garden row, amount of seed, depth to plant, distance between rows, and distance between plants.

The entire book is that detailed on every subject it takes up.

A Tier-Shelf Bed for Mushrooms

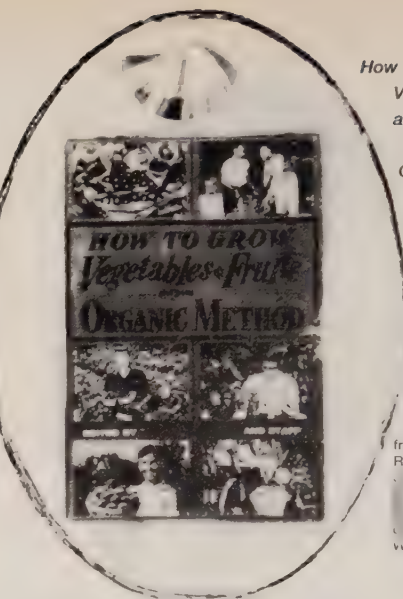
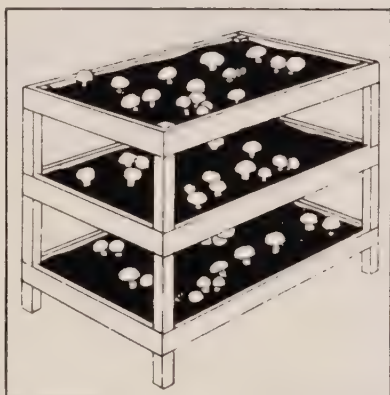

How to Grow Vegetables and Fruits by the Organic Method

ed. J.I. Rodale and staff

1961; 926 pp.

\$10.19

postpaid

Shelter Land

from Rodale Books, Inc. Minor St. S. Penna.

18049

WHOLE EARTH CATALOG

One need not, however, intend raising food for a family of five before this book can be useful to you, and a pleasure. I find it absolutely stimulating just as reading matter. It's pleasing in the way that thumbing through a catalog filled with delights you crave can be pleasing. Browsing in this book reminds one of fundamental things, of soil and water and air, and one's own involvement in the natural scheme of the world. The book is beautiful in the way that native crafts are beautiful: it's alive aesthetically at the same time that it's useful. That's more than one can say about most novels. I own very few books I'd rather have than this one. I recommend it to gardeners of all shapes and sizes, and to aware people in general who enjoy reading books whose themes, images and metaphors are drawn from the world of nature.

[Reviewed by Gurney Norman]

But we are more concerned here with the "meat-eaters" - birds which prefer to eat millions of insect life. A few birds prefer an all-insect diet. They include barn swallows, swifts, house wrens, grackles, flycatchers, brown creepers and some of the several species of warblers. Their bills are long and straight, or long and curved; or they may be short and whiskered; whippoorwills and the nighthawk family belong to this group.

ABC and XYZ of Bee Culture



The first edition of this authoritative book was written in 1877 by Mr. A.I. Root. The current edition, the 33rd, is edited by Mr. R. Root, with the help of H.H. Root and J.A. Root. You get the picture.

We've been told by several people that bee-keeping is one of the easiest ways to make extra money with little effort and a certain amount of down-home adventure. If you are what you eat, food from flowers is hard to beat.

From whatever standpoint - commercial, nostalgic, or amateur scientific - this is a fascinating and useful book. The Roots also have a catalog of bee supplies, a beginner's book (*Starting Right With Bees*), and a magazine (*Gleanings in Bee Culture* - monthly), \$3.00 per year.

[Suggested by Tassajara Zen Center]

MARKETING HONEY.—The beekeeper with four or five colonies of bees will have no difficulty in selling honey to his neighbors. It soon becomes known that he has a few hives of bees and the people in the vicinity, feeling that they can buy "real honey," will go to the neighbor and pay good prices furnishing their own utensils. If the honey is of first quality there is no trouble about selling the entire crop from the doorway.

Starting Right With Bees Catalog Free

100 pp. \$1.00 postpaid

from The Root Company Me. Ohio 44256

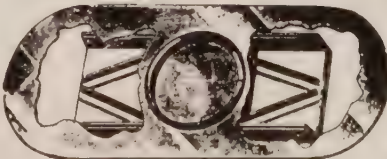

Porter bee escape. The two V-shaped prongs are made of thin strips of brass and are so sensitive that they spread easily to let the bees through at the apex. After the bees pass the springs, the points fly back to position, shutting off a return. If the prongs are bent or damaged they should be reset to 1/16-1/8-inch apart.

Universal Mill

I first ran across C.S. Bell's grinders at the Keams Canyon trading post between the Hopi and Navajo reservations. Then I found one in the VITA catalog: "grinds coffee, corn, soy beans, sugar, mixtral (for tortillas or arepa), garbanzo, seeds, peppers, spices, cocoa, peanuts, wheat, meat, salt, oats, buckwheat, bananas... and like products (wet or dry)." So we ordered one and here it came, with all the grace and precision of a fire hydrant - I had to file the main axle for an hour to get it into the handle. It's fire hydrant red too. But sure enough it grinds stuff and doesn't cost much. C.S. Bell also has power driven grinders and a hand corn sheller.

La Campanita

\$11.55 8 lbs. shipping weight

C.S. Bell Company Oro, Ohio 45133



ABC and XYZ of Bee Culture

A.I. Root et al. 1877; 1966; 712 pp.

\$5 postpaid

In cool weather, so far as conditions will permit the time selected for handling the bees should be between 10 o'clock in the morning and 3 in the afternoon. In warm weather the operator should never stand in front of the entrance - always to one side. First, a little smoke should be blown in the entrance. The cover should be lifted gently and more smoke blown between the cover and the hive before the hive is opened. More par-

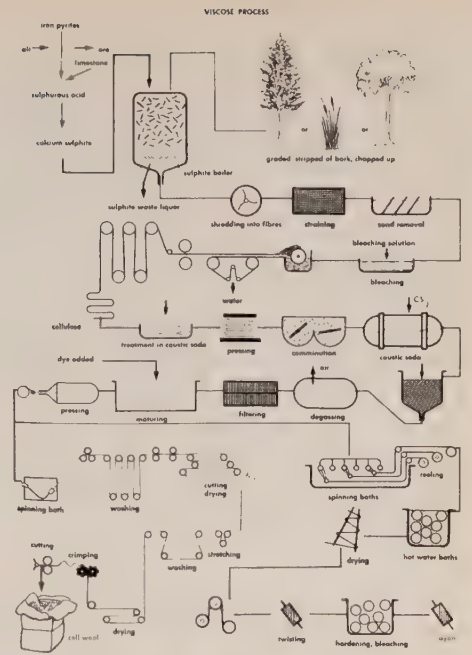
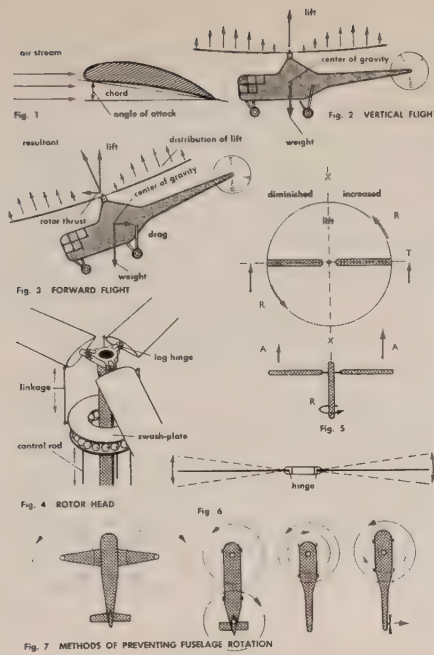

The Way Things Work
1967; 590 pp.
\$8.95 postpaid

from
Simon & Schuster
6 E. 57th Avenue
New York, N.Y. 10020
WORLD EARTH CATALOG

Best book for the bathroom we've seen. Nibble your way to knowledge of technology. Each two pages of the book is a bunch of text and a bunch of diagrams on all the big and little gadgets and processes you can think of, ball-point pens to data-processing. If you develop time travel, it might be interesting to take this book back to the sixteenth century and leave it under some European's pillow. (Now think about contact with alien civilizations.)

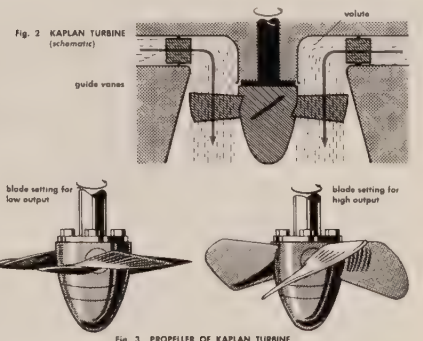
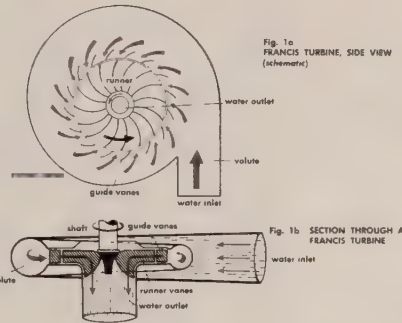

Introduction to Engineering Design

Out of a whole section of books on design in the Engineering Library at Stanford, this book looked far the best. Recently Steve Baer (dome and solar designer) came across it on our editing tables, sat down and paged, then got up and hurriedly wrote a letter to a friend about the book and its author. I asked Steve to pick out some useful quotes and pictures and he wouldn't. "Look anywhere you open it," he advised, then ordered a copy.

Contents of the book include: The Engineering Problem Situation, Design Project Organization, Information and the Need Analysis, Identification of the Problems, Information Sources, Synthesis of Alternatives, Estimation and Order-of-Magnitude Analysis, Engineering and Money, Preliminary Design, Engineering Problem Modeling, The Iconic Model, Conceptual Representation, Expansion of the Criterion Function, Checking in Engineering Design, Optimization, etc., etc.



Fig. 7.4 Possible water channel sections. Water supply project for mountain cabin.

WATER SUPPLY FOR MOUNTAIN CAMP
For another simple example, let us estimate how we would bring water from a running stream into a tank (let's say a 50-gallon gravity tank) to supply water for a vacation cabin in the woods. A natural supply point is 100 ft. away upstream, guaranteeing among other things a clean, continuous water supply. Our problem is transport. Shall we use pipe, an open rick-lined channel in the ground, or a wooden flume or trough? See Figure 7.4.

As we think about this, we disregard the open channel in the ground as too easily contaminated. The pipe could be laid on the ground; and the wood flumes could be suspended from tree trunks and possibly covered as shown by the dashed "board" in the illustration. Thus, we have two reasonable ways of doing this job; the questions now concern cost and convenience.

Next we check the sizes needed. If we wanted the 50-gal tank filled in 15 min, we would need a flow of about 4 gal./min. This is a stream of water about as big as a person's finger when the water is flowing two feet per second, as shown by the equation in the footnote† deriving the cross-sectional area, A, of the stream.

This area would require a pipe one inch in diameter. If we were using the wood "vee" channels, we need two boards each about three inches wide to avoid splashing over, or one-half board foot per running foot of channel (per foot of channel length). (A board-foot is one square foot of wood, one inch or less thick.)

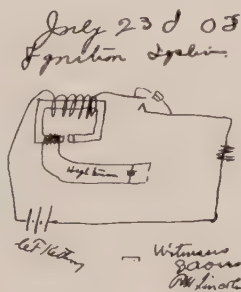

Fig. 6.2 A sketch that changed automobile ignition. (Courtesy General Motors Corp.)

Now we need to arrive at costs. The most convenient reference is a broad-covered catalog (such as that of Sears, Roebuck), in which wood, metal, and other supplies can be found listed at retail prices. Of course, one can also phone the retail plumbing or lumber suppliers. In any case, we find

- Wood: 15¢-20¢ / board-foot in the sizes we need
- 1 in. iron pipe: 30¢ / ft
- 3/4 in. copper pipe: 58¢ / ft (One size smaller than iron pipe for the same flow rate.)

Assuming one-half board-foot for each running foot of wood channel, the comparisons are

- Wood: 10¢ / running foot, materials only
- Iron: 30¢ / running foot, materials only
- Copper: 60¢ / running foot, materials only

Since we would do the work ourselves, the cost of labor is disregarded, and it seems that wood should be our choice. On one final check though, we ask whether these are all the choices. Someone suggests plastic pipe, so we look that up: It is corrosion-resistant, flexible, easily connected, sanitary; it has a smooth interior; it could be in one piece and simply laid on the ground. It seems to be a natural choice. The price of 3/4-in. diameter plastic pipe is 10¢/ft; 1-in. diameter is 16¢/ft. Considering the labor needed with wood or iron pipe, or the cost of copper tubing, and the plastic's sanitary advantages, the plastic pipe (high-density polyethylene) is certainly the preferred choice.

Thus our final estimate is the use of this plastic tubing, probably 3/4-in. diameter at 10¢/ft.

† $A = Q/V$ (area = flow/velocity)
where
 $Q = 4 \text{ gal./min} = 1000 \text{ cu in./min}$ (1 gal = 231 cu in.)
 $V = 2 \text{ ft/sec} = 24 \text{ in.}/(1/60 \text{ min}) = 1500 \text{ in./min}$
 $A = \frac{1000 \text{ cu in./min}}{1500 \text{ in./min}} = 2/3 \text{ sq. in.}$

Introduction to Engineering Design

Thomas T. Woodson
1966; 434 pp.

\$9.95 postpaid

from:
McGraw-Hill Book Company
Princeton Road
Hightstown, N.J. 08520
McGraw-Hill Book Company
1221 River Road
New Rochelle, Missouri 63062
8777 The Wood Highway
Novato, Calif. 94947
or
WHOLE EARTH CATALOG

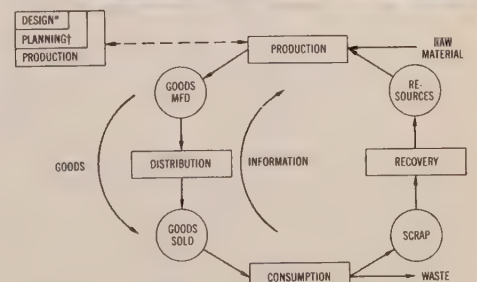

* DESIGN is a part of PLANNING
† PLANNING is a part of PRODUCTION

Fig. 3.7 The production-consumption cycle, showing the place of engineering design.

STAY ON TOP OF
THE WORLD.

subscribe

NOW TO

WHOLE EARTH

AND

save
25%

OFF THE COVER PRICE

800-783-4903

SAVE 25% OFF THE COVER PRICE!

GET WHOLE EARTH FOR ONE YEAR (4 ISSUES) FOR ONLY \$22

Name

Address

City/State/Zip

Bill Me Later

Payment enclosed

Canada: US \$25 includes postage and GST. All other foreign countries: US \$30. Please allow 6 to 10 weeks for first issue.
For new orders only. 309551

SAVE 25% OFF THE COVER PRICE!

GET WHOLE EARTH FOR ONE YEAR (4 ISSUES) FOR ONLY \$22

Name

Address

City/State/Zip

Bill Me Later

Payment enclosed

Canada: US \$25 includes postage and GST. All other foreign countries: US \$30. Please allow 6 to 10 weeks for first issue.
For new orders only. 309551



NO POSTAGE
NECESSARY IF
MAILED IN THE
UNITED STATES

BUSINESS REPLY MAIL
First Class Mail, Permit No. 292, Denville, NJ

POSTAGE WILL BE PAID BY ADDRESSEE

Whole Earth

P.O. BOX 3000
DENVER, NJ 07834-9879



NO POSTAGE
NECESSARY IF
MAILED IN THE
UNITED STATES

BUSINESS REPLY MAIL
First Class Mail, Permit No. 292, Denville, NJ

POSTAGE WILL BE PAID BY ADDRESSEE

Whole Earth

P.O. BOX 3000
DENVER, NJ 07834-9879



TRENDS AND DISCOVERIES

New Scientist is the best evidence we've seen that there are new scientists in the world, young, politically aware, irreverent, active. Every week here's yet another blue *New Scientist* (if you get behind reading, it's hopeless), full of actual news, critique, and gossip of the research world. The magazine is British, so you get perspective on U.S. accomplishments (flattery nonetheless), and report of worldwide activities unreported in most American journals. The Ariadne column is a gem.

[Suggested by Steve Baer]

Two physicists at the University of Rochester, by means of a beautiful experiment, have proved Dirac's contention that the interference patterns of light are produced by single photons interacting with themselves

Should sportsmen take dope? Alcohol may form drugs in the brain

Last week, a report of an apparently outstandingly successful experiment in extra-sensory perception appeared in the "establishment" scientific literature for the first time for more than twenty years. Is ESP scientifically respectable at last?



ARIADNE

A device with more than a little of the Daedalus magic about it was unveiled at Stanford University, California, last week. As part of the finals in a mechanical engineering course, students were asked to build a machine capable of climbing a flight of stairs. Everybody's favourite was a robot which strutted to the top, wheeled, fired a small cannon at the onlookers, waved a Nazi flag, gave a rousing rendition of "Deutschland uber Alles", gave the Nazi salute... and then blew itself to bits. If all else fails, a million dollar job must surely await this young engineer at California's famed Disneyland.

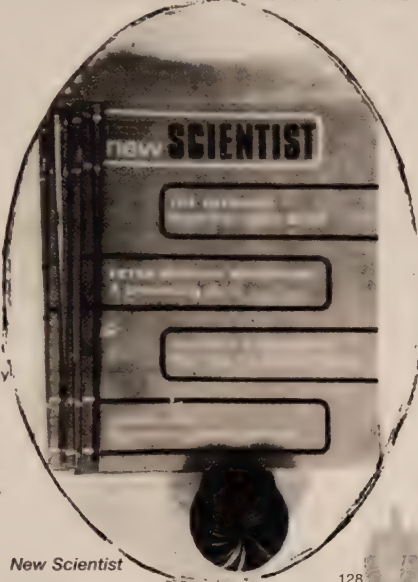

New Scientist
\$16.00 for one year (weekly)
128 pages
London, W. England

Cutting The Cord Complicates Afterbirth
Obstetricians, albeit with the best will in the world, have for about 300 years been meddling unnecessarily with the process of childbirth, and possibly even causing avoidable complications. Dr. M.C. Botha, a South African obstetrician, suggests that by cutting the cord as soon as the baby is born, they may rob the infant of about 90 millilitres of blood—no small measure in a new-born baby. And by tying the cord in the maternal side, before the placenta is delivered, obstetricians may be inhibiting expulsion of the placenta (afterbirth) and causing postpartum haemorrhage.

Recently, Solomon Snyder and Elliott Richelson of the Johns Hopkins School of Medicine, Baltimore, were playing around with molecular models of a number of psychedelic drugs. It suddenly occurred to them that each of their models could be formed into a configuration that approximated certain elements of the drug d-lysergic acid diethylamide, better known as LSD. From this chance observation Snyder and Richelson have now developed an elegant model that can predict a molecule's psychedelic potency from its structure (*Proceedings of the National Academy of Sciences*, vol. 60, p. 206).

All the way with DNA

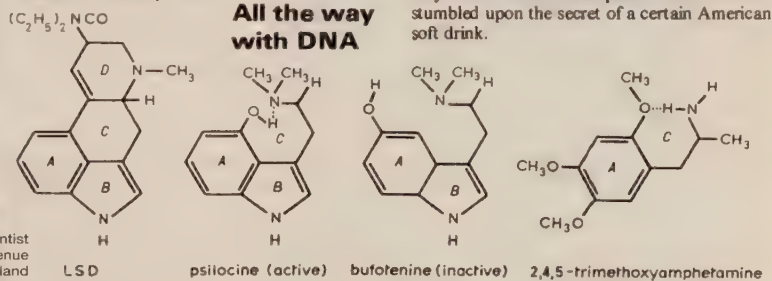

The new substance, however, will be unique in being addictive and *nothing else*—in mathematical parlance the first "trivial" drug. Being totally bland and insipid, and making nobody happier even temporarily, it will neither attract the attention of the Mafia or the kick-seeking young, nor call down denunciation from the elderly, repressed puritans of the Bench. Its undetectable influence will restore the junkies and compulsive pill-gulpers to such normality that they may scarcely notice their dependence on this symptomless nonentity. But Daedalus fears that he may have been anticipated—that he has stumbled upon the secret of a certain American soft drink.

24 Industry & Craft

Cocoons for the millions

House shells of foamed epoxy resin can be built up from the bare earth in a matter of hours using a simple travelling mould controlled by two men. The cheapness and speed of erection offer a realistic approach to the world-wide problem of building low-cost housing

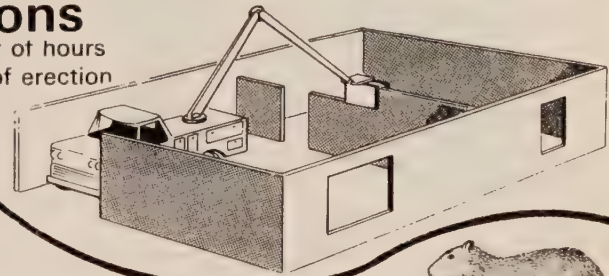

Scientific American \$8.00 for one year (monthly)

Good Old *Scientific American*.
from: Scientific American, 415 Madison Avenue, New York, N.Y. 10017, via newsstands.



Crops without Tillage

A new machine method for planting row crops such as corn and soybeans promises to increase U.S. agricultural productivity by cutting the time usually spent in preparing the land with plow and harrow. In northern farm regions with short growing seasons the "no tillage" planting machines ensure maximum growing time and greater yields per acre; in southern farmlands, after the early-summer harvest of winter-grown grains, the machines allow a second crop to be planted quickly amid the harvest stubble, thus guaranteeing two crops a year.

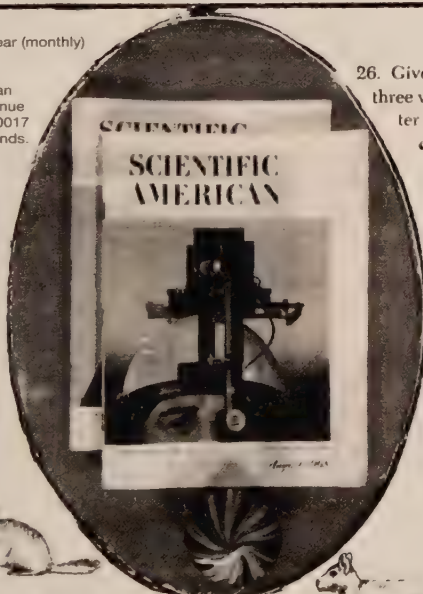

Reporting on the progress of no-tillage farming at the annual meeting of the American Society of Agricultural Engineers in June, W. R. McClure of the University of Kentucky stated that the time-saving technique had become popular in his area soon after modified corn planters became available in 1967, capable of sowing corn and soybeans in harvest stubble and even in unbroken sod. In addition to the time and money saved by omitting conventional tillage, McClure noted, the no-tillage system affords superior erosion control and, because it leaves natural mulch undisturbed, is far less wasteful of soil moisture than plowing and harrowing are. McClure and his associates at the university conclude that Kentucky farmers could eventually increase their earnings by more than \$150 million a year by adopting the practice.

We have examined the trait theory from a number of different viewpoints and have found that the Newark and Detroit survey data do not support it. The rioters are not the poorest of the poor. They are not the hard-core unemployed. They are not the least educated. They are not unassimilated migrants or newcomers to the city. There is no evidence that they have serious personality disturbances or are deviant in their social behavior. They do not have a different set of values. None of these factors sets the rioter off from the rest of the community in a way that justifies considering him a personal failure or an irresponsible person. In fact, on some of the "prosocial" items, such as education and occupational aspiration, the rioter compares favorably with the nonrioter or even surpasses him.



26. Give at least three ways a barometer can be used to determine the height of a tall building.

mg. (Thanks to Alexander Calandra.)
He will tell you the height of the building and offer him the barometer if he wants it. (1) Lower the barometer by a string from the roof to the street, pull it up and measure the string. (2) Drop it off the roof, note the time it takes to fall and compute the distance from the formula for falling bodies. (3) On a sunny day, find the ratio of the barometer's height to the length of its shadow and apply this ratio to the length of the building's shadow. (4) Take barometer readings at the base and the top of the building and compute the height from formulas relating altitude and barometric pressure. (5) Find the superimposed pressure.

Bioholography

The latest example of a technological innovation turning out to be anticipated by a natural process may be in the field of holography, or photography by wave-front reconstruction. The holographic principle is involved in a startling conjecture put forward by a Hungarian investigator to account for the extraordinary sensitivity of the ultrasonic echo-location systems used by bats, whales, dolphins and porpoises to "see" in the dark. This capability has been known for many years to resemble modern sonar, but no satisfactory explanation has yet been offered for the fact that these animals can apparently distinguish between targets of different shapes and can discriminate between their own signal and those emitted by their companions, even though the frequency of the pulses is the same.



Writing in *Nature*, Paul Greguss of the RSRI Ultrasonic Laboratory in Budapest maintains that the characteristics of the animal systems suggest that the animals perceive not only the amplitude but also the phase of the ultrasonic waves, which they can discriminate by using a coherent "background" level of ultrasound as a reference. In other words, the animals are using a version of the holographic technique.

Industrial Design

Design clean and clear, and ingenious, and maybe superficial (the debate is underway) is the stamp of two generations of designers that now make up a friendly Establishment. The best window into their domain besides World's Fairs is the British Magazine, *Industrial Design*.

[Suggested by Jay Baldwin]

Junk as art, screens, etc.

In flame cutting, a series of torches cut custom parts from steel sheet. The remainder of the sheet is usually sent to the scrap heap for eventual salvage by steel makers. But at the Reliance Steel & Aluminum Company, someone thinks that the patterned perforations in sheet form might have other uses in sheet form might have other uses. Admirers of such industrial art, or people with potential uses for these by-product plates, might want to discuss the matter with Mr. Robert Zurbach, a Reliance V.P., at 2537 East 27th Street, Los Angeles, California.

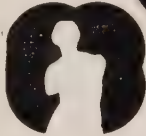

Are designers obsolete?

A monthly source of the new materials, design tools, technological advances, and components particularly important to active designers.



Industrial Design
\$10.00 for one year (10 issues)

Industrial Design
40th Street
New York, N.Y. 10022

Suggested bibliography
Chapanis, Alphonse. "Man-Machine Engineering." Belmont, California: Warsworth Publishing Co., 1965.
Clark, Grahame. "The Stone-Age Hunters." New York: McGraw-Hill, 1967.
Damon, Stoudt and McFarland. "The Human Body in Equipment Design." Cambridge: Harvard University Press, 1966.
Edholme, O.G. "The Biology of Work." New York: McGraw-Hill, 1967.
Ewald, J.R. "Environment for Man—The Next Fifty Years." Bloomington, Indiana: Indiana University Press, 1967.
Fogel, L.J. "Biotechnology: Concepts and Applications." Englewood Cliffs: Prentice Hall, 1963.
Gagne, R.M. "Psychological Principles in System Development." New York: Holt, Rinehart and Winston, 1962.
Gregory, R.L. "Eye and Brain." New York: McGraw Hill, 1966.
Jones, J.C. and Thornely, D.G. "Conference on Design Method." New York: McMillan, 1963.
McCormick, E.J. "Human Factors Engineering." New York: McGraw-Hill, 1964.
McGaugh, J.L., Weinberger, N.M., Whalen, R.E. "Psychobiology" (readings from "Scientific American"). San Francisco: W.H. Freeman & Co., 1967.
Meister, D. and Rabideau, G. F. "Human Factors Evaluation in Systems Development." New York: John Wiley, 1965.
Morgan, Cook, Chapanis and Lunni "Human Engineering Guide to Equipment Design." New York: McGraw-Hill, 1963.
Murrell, K.F.H. "Human Performance in Industry." New York: Reinhold, 1965.

Rosch and Burke. "Kinesiology and Applied Anatomy." Philadelphia: Lea and Febiger, 1967.
Sinaiko, H. Wallace. "Selected Papers on Human Factors in the Design and Use of Control Systems." New York: Dover Publications Inc., 1961.
Smith and Smith. "Perception and Motion." Philadelphia: W.B. Saunders and Co., 1962.
Vernon, M.D. "Experiments in Visual Perception." Baltimore: Penguin Book Inc., 1966.

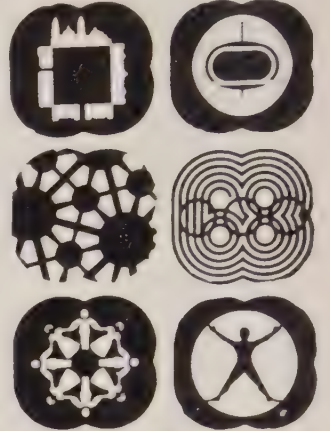

MAN/MACHINE SYSTEMS INTERACTIONS

Product Engineering

Roy Sebern pointed out the main satisfaction of reading *Product Engineering*: in the usual magazines such as *Popular Science*, everything has the tone of "I-wish-they'd-make..."; whereas in *Product Engineering* it's "We are making..." The magazine has good reporting and excellent editing. Increasingly it is going beyond the question of how to make stuff into why make stuff. Departments include Research & Technology, Mechanical Design & Power Transmission, Hydraulic/Pneumatic Power & Control, Materials & Manufacturing, Product Planning & Management, and the Engineer & His Profession.



Developments to watch

Flying belts ruled by muscle-power

It may be only a matter of time before researchers take some of the controls off jet-flying belts. This step will allow man to rely on his own sense of balance and muscle control while swooping around the sky almost at will.



Igloo-like houses of urethane foam are formed by spraying over fabric and cable forms. Dwellings of almost any size or shape can be built in a matter of minutes.

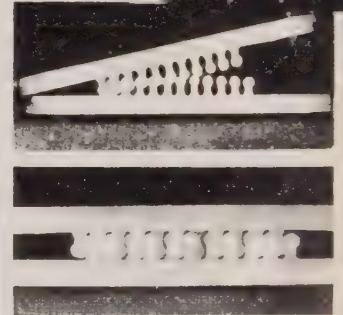
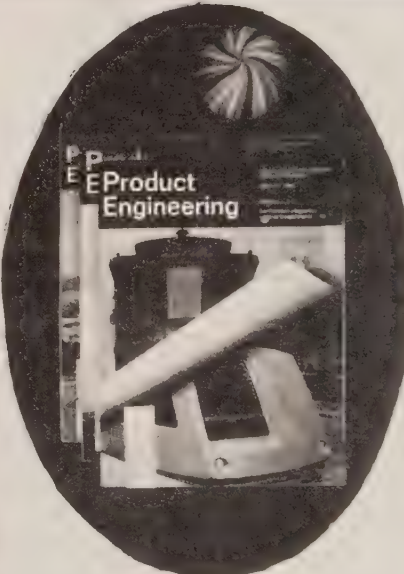

Smooth surfaces of nylon or acetal snap together without need for precise alignment. They hold firmly until pulled apart by a specified force.

Product Engineering

\$15.00 for one year (bi-weekly)

from
F...nt Manager
F... Engineering
F... 430
H...wn, N.J. 08520

Inventors of today need not feel as "lone" as they have in the past, partly because of the Inventors Assistance League, which was set up in Los Angeles 18 months ago by Ted De Boer (photo, top right). The League was founded to help the inventor make his brainchild a marketable, commercial reality.

For the movies, the holographic information of an entire square-image field seen from one horizontal plane is contained in a narrow horizontal section of film. Vertical motion of this "strip hologram" at any speed through a laser-illuminated viewing aperture results in a vertically scanned but essentially stationary 3D image. So, says De-Bitetto, if a sequence of such strip holograms of a progressively changing scene is recorded by pulse laser techniques, the strip hologram sequence reconstructs what appears to be a continuous motion of the 3D scene. The sequence of strips is simply moved vertically through the laser-illuminated viewing aperture, at any velocity.



Clearinghouse

Its full name is "Clearinghouse for Federal Scientific and Technical Information," it's managed by the U.S. Department of Commerce, and it's quite a service. All current unclassified R&D (research and development) done for or by the Government is available through Clearinghouse; this amounts to 30,000 new documents each year. Specific accesses are: U.S. Government Research and Development Reports (December 1,000 new documents twice a month), \$22/year; Fast Announcement Service, for as many as 57 subject areas, delivered constantly, \$5/year; and Technical Translations, twice a month, \$12/year. These are indexes. Once you find what you want you order a paper copy (hard copy) for around \$3 or micro-film (microfiche) for around \$.65. The following examples of listings are from the Fast Announcement Service.

[Suggested by Jon Dieges]

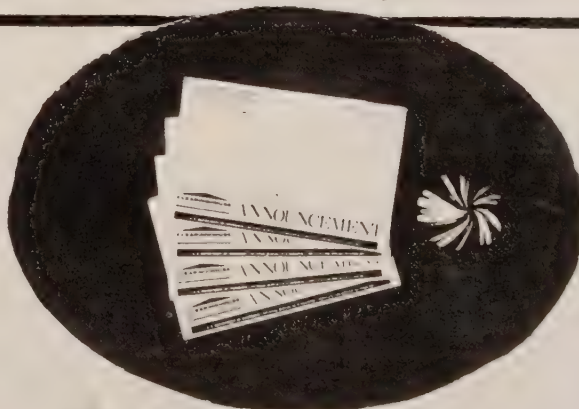

Write for information and order forms to:
U.S. Department of Commerce
Clearinghouse for Federal Scientific & Technical Information
Springfield, Va. 22151

CLEARINGHOUSE FOR FEDERAL SCIENTIFIC AND TECHNICAL INFORMATION

The Fast Announcement Service—recommended for those who want more mail.

AD-672-250 - THE THEORY AND PRACTICE OF BLACKMAIL, D. Ellsberg, Rand Corp., Santa Monica, Calif., July 68, 40 p

AD-674 025 - OPTICAL OR GRAPHIC INFORMATION PROCESSING (INFORMATION SCIENCES SERIES), Defense Documentation Center, Cameron Station, Alexandria, Va., Sept. 68, 229 p. . . .DDC bibliography containing 183 references grouped under the following headings: (1) display devices and theory; (2) character recognition; and (3) pattern recognition.

PB-179 385 - MANUAL ON DESIGN FOR LOW-COST AND AIDED SELF-HELP HOUSING, Dept. of Housing and Urban Development, Washington, D.C., for AID, Jan. 57 (reprinted June 67), 111 p.

AD-674 753 - ACOUSTICAL HOLOGRAPHY OF NONEXISTENT WAVEFRONTS DETECTED AT A SINGLE POINT IN SPACE, A.F. Metherell and S. Spinak, McDonnell Douglas Corp., Huntington Beach, Calif., May 68, 17 p. Describes a configuration based on an extension of the reciprocity theorem and realized by physically interchanging the source and detector. The hologram-recording operation is executed by scanning the source throughout a plane and sampling the resultant wavefront as a function of time with a stationary detector

Science and Civilization in China, Volume IV, Part 2

Sandy Tcherepnin just asked delicately if I've read Needham's *Science and Civilization in China*.

Sandy, I don't know anybody who's read Needham's *Science and Civilization in China*. This is gonna be a reputation review. People say it's a great book. I'll page through, pick out two graphic pictures, two bally quotes, and advise everybody to go spend \$35.

Jim Fadiman was even more polite: "What's Needham doing in the CATALOG?"

Nostalgia. This is the volume about Mechanical Engineering. Since many communities and individuals seem intent on reenacting human technological history, here's their opportunity not to be limited to Western technology. You too can build the first cantilevered bridge, devise the indestructible junk sail (I read about that in Needham's *Order and Life*, a biology book), and build epic water wheels.

For all we know, an enormous shuck is in progress. Has anybody out there read *Science and Civilization in China*?

By the time Marco Polo was in China (c. +1285) Man-lifting kites were in common use, according to his description, as a means of divination whereby sea-captains might know whether their intended voyages would be prosperous or not.

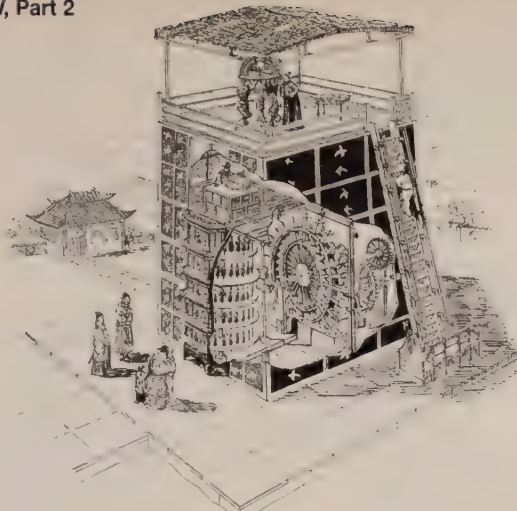
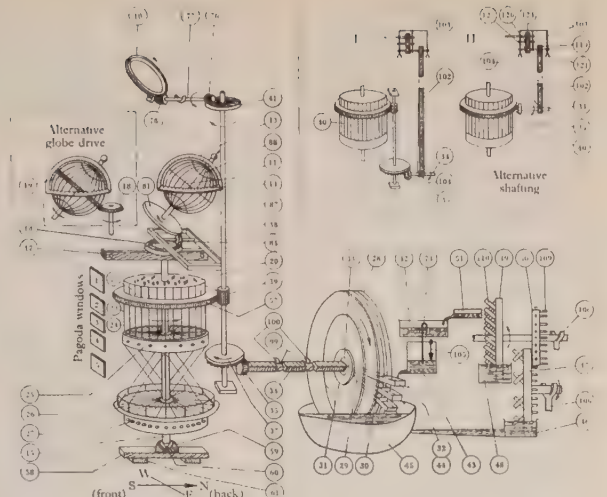

Fig. 650. Pictorial reconstruction of the astronomical clock-tower built by Su Sung and his collaborators at Khaifeng in Honan, then the capital of the empire, in +1090. The clockwork, driven by a water-wheel, and fully enclosed within the tower, rotated an observational armillary sphere on the top platform and a celestial globe in the upper storey. Its time-announcing function was further fulfilled visually and audibly by the performances of numerous jacks mounted on the eight super-

imposed wheels of a time-keeping shaft and appearing at windows in the pagoda-like structure at the front of the tower. Within the building, some 40 ft. high, the driving wheel was provided with a special form of escapement, and the water was pumped back into the tanks periodically by manual means. The time announciator must have included conversion gearing, since it gave 'unequal' as well as equal time signals, and the sphere probably also had this (see p. 456).



Su Sung's treatise on the clock, the *Hsin I Hsiang Ea Yao*, constitutes a classic of horological engineering. Orig. drawing by John Christiansen. The stercorarium was actually inside the tower, as in the model of Wang Chen-To (7). The historical significance of the mechanical rotation of an astronomical instrument (a clock-drive) has already been discussed in Vol. 3, pp.359ff.; cf. also p.492 below.

26 Industry & Craft

Science and Civilization in China Volume IV Part 2 Mechanical Engineering

Joseph Needham 1965 759 pp. \$35.00 postpaid

from the University Press, 100 Brookline Avenue, New Rochelle, N.Y. 10801 or WHOLE EARTH CATALOG



'The undertaking of such a gigantic task single-handed reveals a creative spirit worthy of all admiration. Its completion will make it an unprecedented and epoch-making work in the history of science, and it has already aroused the interest of scholars in every country, who regard it as a masterpiece of modern scientific study. It cannot fail to direct the attention of the learned world to ancient Chinese culture and science.'

YU FANG-HU in *Kuang Ming Jih-Pao* (Peking)

'This only enhances our amazement at Needham's ability to discover in the ocean of datable Chinese literature so many anticipations of present-day scientific knowledge. Even his tentative speculations are as arresting as his conclusions.'

A.W. HUMMEL in *American Historical Review*

Silvo Catalog

Tools tools tools tools tools. Brand names. No particular discrimination or evaluation. If you know what you want, it's probably here. Prices apparently good. Audel books, for example, cost 15% less than from the publisher or bookstores. Minimum order \$10.

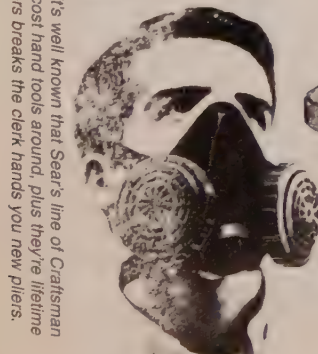

Jorgensen Band Clamps—Canvas, steel band.—For the many applications where clamping round or irregularly shaped sections, such as furniture frames, aircraft sections, tanks, or columns, presents a difficult problem. The pre-stretched canvas band is 2" wide; the steel band (optional if specified) is 1 3/4" wide. Both are quickly adjustable from either end thru the screw head.

Canvas band is recommended for nearly all uses—it is more easily handled and does not kink; steel band should be used on round shapes only. Self-locking cams hold the band securely.

Canvas Band—
4210-A2 6 lbs. 10' band ... \$13.65
4220-A2 6 lbs. 20' band ... \$16.25

Glendole Respirators — For Dust, Paint, Pneumococcus Mists, and Chronic Acid Mist Superior fit, no metal parts, can be completely taken apart for cleaning and sterilization. Replaceable Filters and Cotton Facepiece (cotton face piece absorbs perspiration, prevents skin irritation).

GR1000-G20 P—Single Unit \$3.99
GR2000-G20 P—Double Unit \$5.20
F10-G20 Box of 10 filters ... \$1.25
F11-G20 12 Cotton Face. pieces \$1.35

CURVED CLAW



Estwing Claw Hammer — Solid steel — with **Leather Grip**.
E16C-E6 P—16 oz. claw ... \$3.59
E20C-E6 P—20 oz. claw ... \$3.85

Estwing Original Unbreakable Leather Grip Tools. Forged One-Piece Head and Handle — Strongest Construction Known — **Genuine Leather Grip** — Withstands All Exposures.

Model M58 Kol Portable Cement Mixer, complete with 1/4 H.P. 110 V. motor. One man can mix 9 cu. ft. of cement an hour with this handy mixer. The 5 gal. pail doubles as a mixing drum and can be removed to pour the cement. The rugged unit is easy to clean, needs no fastening down, can mix a batch in 2 minutes. Farmers and gardeners can use it for mixing feeds and seeds. Ideal for pouring patios, making barbecue grills, setting fence posts. Instruction booklet incl.

M58-K10 H—35 lbs.—with motor ... \$39.95

Model M58X Kol Portable Cement Mixer—Same quality features as above but less 1/4 H.P. motor.
M58X-K10 H—22 lbs.—less motor ... \$23.25

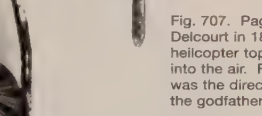
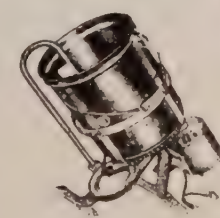

Fig. 707. Page of drawings sent to Cayley by Dupuis-Delcourt in 1853 illustrating an improved Chinese helicopter top which would mount more than 90 ft. into the air. From Hubbard & Ledegoer (1). This was the direct ancestor of the helicopter rotor and the godfather of the aeroplane propeller.

Fig. 689. Typical Chinese horizontal windmill working a square-pallet chain-pump in the saltens at Taku, Hopei (king, 3). The fore-and-aft mat-and-batten type sails luff at a certain point in the cycle and oppose no resistance as they come back into the eye of the wind (see diagram on p. 559)

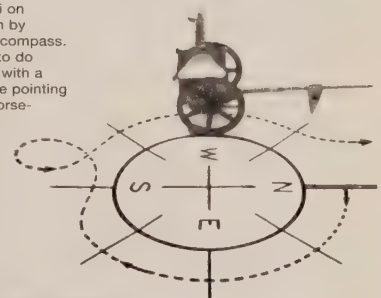
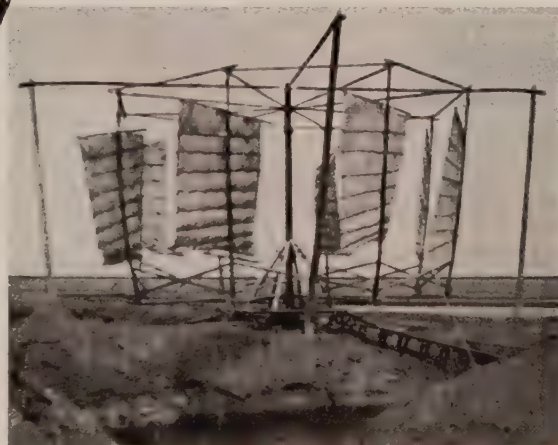
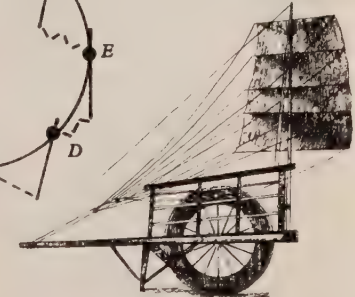

Fig. 519. Diagram of a sailing wheelbarrow from van Braam Houkgeest (+1797), showing the batten sail and multiple sheets so characteristic of Chinese nautical practice. (cf. Sect. 29g below).



Silvo Catalog 160 pp.

\$25

from: Silvo Hardware Co. 107 N. 7th Street Philadelphia, Pennsylvania 19106

Brookstone Tools

If precision tools are what you need, this gentlemanly company will comply. They're fastidious about what they list, and they are good to the customer. ("We don't lead you on with prices 'subject to change without notice.")

[This catalog and Silvo suggested by "Armchair Shopper's Guide" (see p. 44)]

HACKSAW CUTS ANY DEPTH, STRAIGHT OR CURVED

Remarkable "endless" hacksaw cuts to any depth, even cuts curves, because no frame interferes with blade. All work is done forward of casing, by reciprocating blade. Does "impossible" jobs.

After drilling a hole, blade is easily inserted for sawing out parts of sheets, panels, flooring, etc., as in sketch. Blade breakage is reduced because blade is supported in front casing on 3 hardened steel bearing balls.

Enclosed spring returns blade automatically after each forward stroke.

Well made. Polished chrome plated tube. Polished, nickel plated fittings. Enamelled casing and body. Uses standard 10" and 12" blades available everywhere. About 15" long. 67A-1293 Endless hacksaw \$7.95

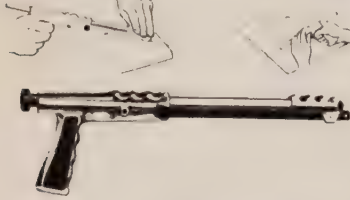

D 8-1/2" shears. All-round shears for shop, office, shipping room, home. Heavily forged for toughest work. Won't bend, even using two hands. Stays sharp — the pair we first tested is still in daily use in our shipping room after a year, on tough paper and cartons, isn't dull yet! Extra-comfortable finger loops prevent fatigue. Precision-fitted to cut filmiest fabrics without ravelling. A masterpiece of scissor making.

67A-1357 8-1/2" shears \$6.95
Six & up Each \$6.25

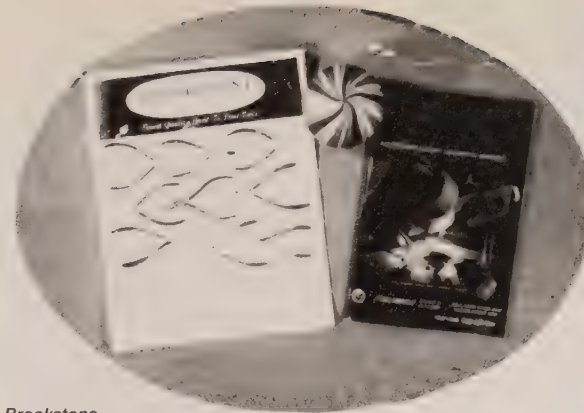

Brookstone Catalog
23 pp.

INTERNAL PIPE WRENCHES ARE TROUBLE SAVERS

\$25

Brookstone Company
Road
Boston, Mass. 01098



FLEXIBLE FILES DO WHAT OTHERS CAN'T

These amazing files are flexible plastic strips impregnated with super-hard aluminum oxide abrasives. You can bend them almost double without breaking. You can snap them into special shapes. Now you can file and polish curved surfaces and otherwise inaccessible places.

They're waterproof, oilproof — for use wet or dry. Excellent for shaping and fitting, and for fine finishing and polishing all metals (even hard steel) without scratching. Remove burrs, tool marks, corners. Touch up cutting tools. Smooth off sharp edges, even on hard glass and ceramics.

Electrically non-conductive — safe on live circuits. Unequaled for dressing and burnishing contacts, line starters, limit switches, commutators, relays.

Catalog Number	Width in.	Length in.	Thick. in.	Grit	Each
67A-1103	1/2	4-1/2	.040	80 (coarse)	20c
67A-1104	1/2	4-1/2	.040	120 (medium)	20c
67A-1105	1/2	4-1/2	.040	240 (ex-fine)	20c
67A-1106	1/2	4-1/2	.040	320 (polish)	20c
In lots of 10 dozen					\$2.15/ doz.

Jensen Tools

Electrical Tools primarily.
All prices postpaid.

Jensen Catalog
65 pp.

Fre

Jensen Tools and Alloys
5001 West Indian School Road
Flagstaff, Arizona 85018

MODEL 355 MIDGETESTER

So very small (2-3/4 x 4-1/2 x 1") it easily slips into your shirt pocket. No wonder the 355 Midgetester is so popular with all who must make basic voltage and resistance measurements "in the field." Features self-shielding movement and 10,000 ohms per volt sensitivity on both AC and DC ranges. Measures 0-3, 0-12, 0-60, 0-300, and 0-1200 V AC or DC. Has four resistance ranges (R x 1, R x 10, R x 100, and R x 1K). Accuracy ±3% DC and ±5% AC. Furnished complete with test leads and manual. Case available. Note: The 355 is an optional component in the JTK-16 tool kit (P. 36).
50B417 TESTER \$50.00
50B425 CASE 5.50



ELLIS "MAJOR" INSPECTION KIT

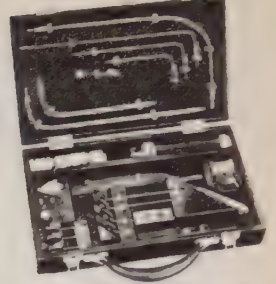

For close and accurate examination of equipment not normally accessible to the naked eye. The kit consists of a series of varying-length probes fitted with miniature electric lamps and lenses. By using these light probes and a combination of adjustable mirrors and magnifying fittings included in the kit, the most inaccessible spots may be viewed through very small apertures. Used for the inspection of waveguides, DC, S₁, and Q bands), cavities, pumps, dies, valves, printed circuits, small motors, hydraulic systems, relays, switchboards, and electronic components (to name just a few). All parts interlocking and interchangeable. Included are the basic battery handle (complete with 2 "D" batteries), a 15" flexible probe, 5 rigid probes, 3 magnifying lenses, an adjustable mirror attachment with adapters, an acoustic magnifier, an illuminated magnifier, a mirror handle, 2 long-stem mirrors, 2 magnifying mirrors, an adjustable mirror with handle, and additional lenses and bulbs. All stems are mounted in a handsome wooden case as shown above.
348672 \$155.00



COMPACT TOOL AND KNIFE CHEST #87

A smaller version of the #89 deluxe kit. Contains most of the tools needed for producing wooden mockups and models. This kit includes a light-duty knife, medium-duty knife, heavy-duty knife, complete assortment of knife blades, gouges, routers, punches, plus a planer, sander, saw, spokeshave, a balsa stripper, steel rule, pin vise, screwdriver, and assorted drill bits. Packed in a fitted wood chest.

CAT. NO. 87

NET EACH \$18.50

Miners Catalog

Mac Taylor, head of Exploration Laboratories, says this is the only Miners Catalog. We're glad it's a good one.

[Suggested by Mack Taylor]

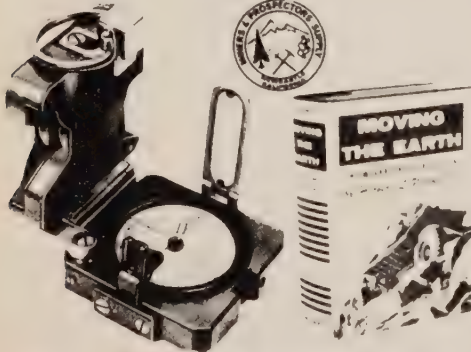

MODEL G1717 ENGINEERING COMPASS. Similar to Model G1719 Geological Compass except that it does not have pendulum clinometer, level bubble or extension rule. This is a fine instrument for most engineering measurements.

The compass and optical clinometer scales permit rapid reading of horizontal and vertical angles with a precision unusual in a hand-held compass. Weight with case 9 ozs. Complete..... \$72.50

ATLAS OF LANDFORMS by James L. Scovel et al. A terrain study atlas compiled essentially from the series of 100 topographic maps illustrating typical landforms published by U. S. Geological Survey. Text material, aerial photographs and diagrams. Effective guide to land form study. 14x11 1/4, 168 pp., 1965, F1 binding. \$0.95



Miners Catalog Free
42 pp.

Miners Catalog
42 pp. and Prospecting
in Street
Title. Calif

Blasters' Handbook

It was the gay bomber of Libre that put us on to blasting as constructive catharsis. With explosives you can cut, dig, shape, and practically whittle. While suppliers are understandably touchy in the city, you can usually get dynamite without heavy credentials in rural areas. It costs something around \$15 for a fifty pound box.

This book published and updated by Dupont, has been around for 26 years. It is well regarded.

DIGGING POLE HOLES

Dynamite is useful in digging both shallow and deep holes for fence posts and for telephone and other classes of poles.

In hard ground and medium shale, any soft surface material should first be removed to the full diameter of the desired hole. For shallow holes, a small borehole should be drilled or punched along the axis of the pole hole to about the depth required and loaded with a small charge of 40 per cent "Red Cross" "Extra" primed with blasting cap and fuse or an electric blasting cap. Double caps are recommended as a safety precaution (Figure 31-A-1). For best results, the hole should be fully stemmed. The blast will loosen the hard material and aid removal by shoveling.

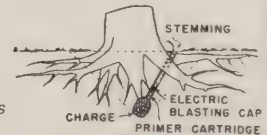

FIG. 218—In Loading a Small Lateral Rooted Stump the Charge Should Be Kept Well Down

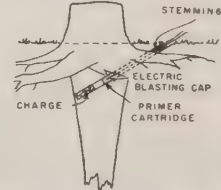

FIG. 219—When Blasting Tap Rooted Stumps, Charge May Be Loaded into a Hole Bored into the Tap Root at Angle Shown.

Stumps in the Pacific Northwest are unusually large and heavily rooted. In most cases, therefore, work in that region will be discussed separately.

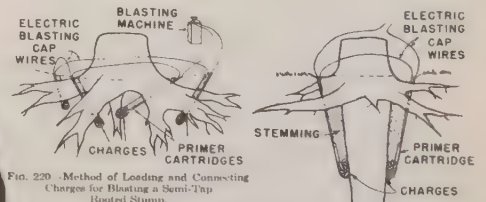

FIG. 220—Method of Loading and Connecting Charges for Blasting a Semi-Tap Rooted Stump.

FIG. 221—Blasting a Tap Rooted Stump Means of Charges Placed in Hollow Dug Alongside the Root.

Blasters' Handbook - A Manual Describing Explosives and Practical Methods of Use. 1942. . . 1968; 524 pp.

\$6.00 postpaid from
Development Section
Explosives Department
Department of Nemours & Company, Inc.
Wilmington, Delaware 19898



Direct Use of the Sun's Energy

The best book on Solar Energy that I know of. Any curious and intelligent person can learn a great deal about our planet and ourselves by reading this book about ways of using sunlight. There are many numbers in the book but the math never goes beyond 8th grade arithmetic. The book is clear and simple whether talking about heating water -

For general domestic use of hot water for bathing and washing dishes a temperature of 135°F (57°C) is considered adequate and 20 gal per person per day is a reasonable consumption. In many sunny climates these requirements can be met with an insulated storage tank and solar radiation absorber which has an area of 0.75 ft² gal-1 of hot water. A family of four would need a tank of 80 gal and a solar absorber of 60 ft².

or photo chemical reactions -

The photo dissociation of iodine (I₂) molecules into atoms absorbs most of the visible light of the sun with a considerable amount of energy, but the iodine atoms recombine so fast that the energy cannot be retained. It is immediately evolved as heat during the exposure to light.

I read the book on a Greyhound bus in Texas two years ago and it has changed my life and my way of thinking.

[Reviewed by Steve Baer]



11. World wide distribution of solar energy in hundreds of hours per year. [Adapted with permission from Solar Energy, cover, 1, no. 1 (1957).]

Direct Use of the Sun's Energy

Farrington Daniels
1964; 374 pp.

\$2.45 postpaid

from
Yale University Press
323 Chestnut Street
New Haven, Conn. 06511
Order from
WORLD EARTH CATALOG

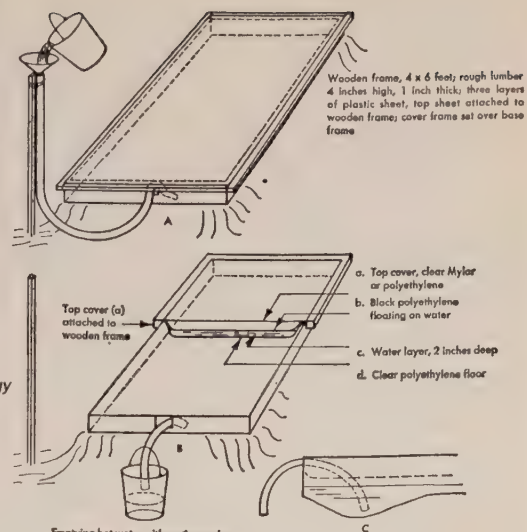

29. Inexpensive solar water heater. A. Filling with cold water. B. Emptying hot water with suction syphon. C. Side view, showing position of end of hose.

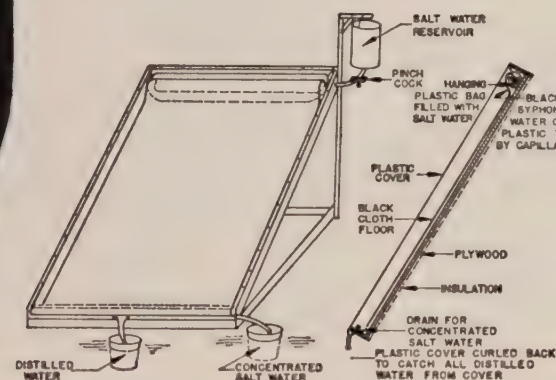

32. Tilted plastic still of simple construction.

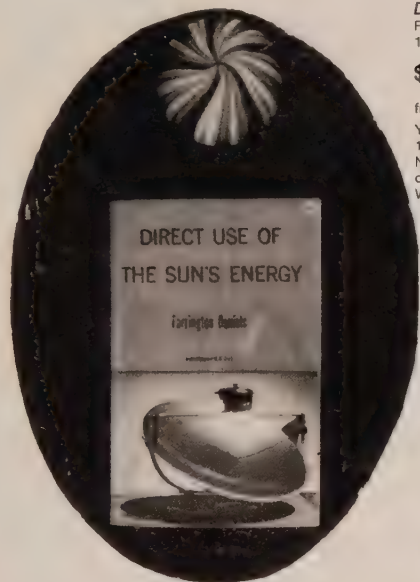

Industry & Craft

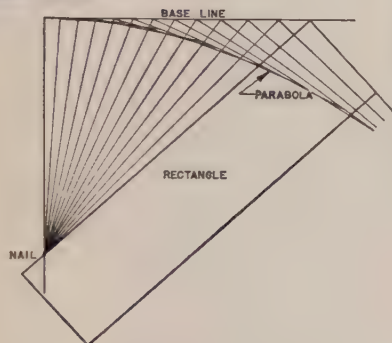

18. Method for drawing a parabola.

Structure, Form and Movement

The usual procedure is that R&D comes up with a new process, it's implemented for several years, and then some biologist says Hey did you know porpoises did that? (or snakes did that, or bees or elm seeds). And everybody says My, my, ain't Nature smart.

Herr Hertel and colleagues is trying to reverse the order, learn from nature first, save time and stay humble. (This approach now has a name, "bionics"; a book by that title that's around is terrible.)

This book may be too expensive for its direct usefulness, but it thoroughly displays the approach that research may take to bugs, birds, fish, etc. for yield in navigation, flight, streamlining, etc.

Structure, Form and Movement

Heinrich Hertel from World Publishing Company
1963; 1966; 251 pp. 100 Avenue
New York, N.Y. 10022

\$17.50 postpaid

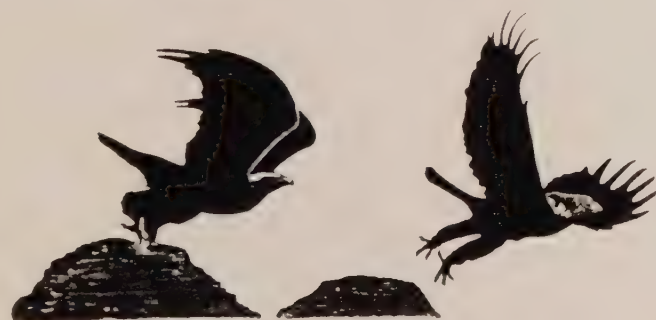
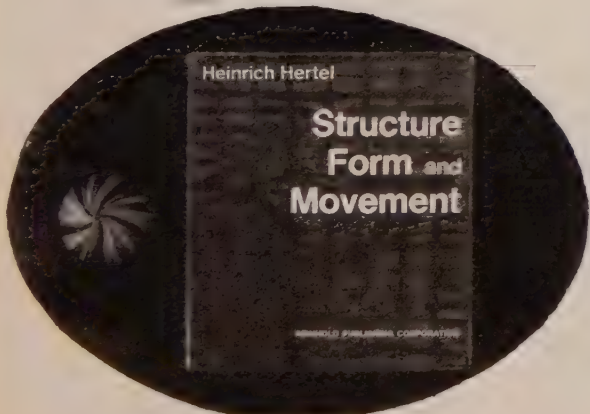

Golden eagle. Leaping off. Legs flexed at left, extended at right

The hand remiges of birds are masterfully perfected to obviate flutter:

- The hollow cross section of the supporting frame consisting of the feather quill is continuous over the entire length and approximates a cylinder, which resists torsion well. This cross section also improves resistance to bending.
- The ultralight construction of the vanes ensures minimum moment of mass about the quill axis.
- Variations in aerodynamic forces during oscillation affect 25% of the profile depth. Consequently, the form of the remiges, with narrower anterior vane sections and broader posterior vane sections, is appropriate for aeroelastic reasons. In the primary feather shown in figure 65, the resultant of aerodynamic forces lies behind the shaft.
- With this aerodynamically desirable arrangement it is impossible to locate the resultants of mass distribution ahead of the torsion axis.
- The arrangement of the three axes (in order from front to back: torsion axis, centroidal axis, aerodynamic axis) is thoroughly favorable for achieving a high critical velocity.
- Considerable damping of the oscillation system is provided by the foam filling (support of the coverts).

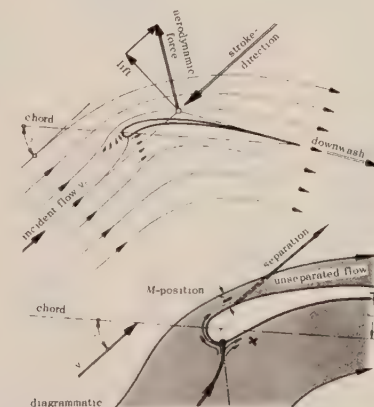

Fig. 52 Beginning of take-off = wing stroke forward and down
incident flow - downwash - forces.
Below: stagnation point; flow around the leading edge

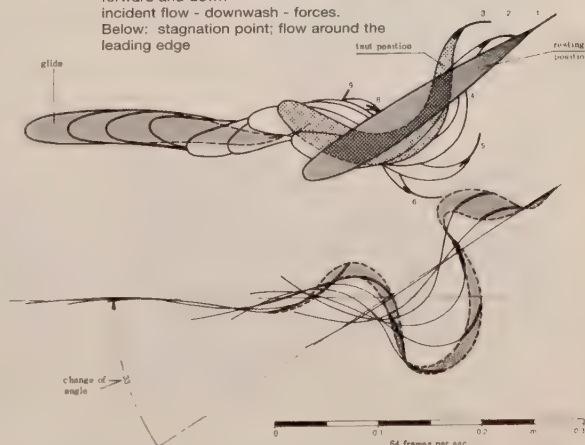

Fig. 204 Starting thrust-lunging of trout (*Salmo gairdneri*) Top: progress of movement according to motion picture record. Bottom: fin stroke.

Van Waters & Rogers

A few years back, when I needed to make a darkroom sink, Jerry Stoll told me about miraculous substance unaffected by wet, heat or chemicals that could be painted on plywood. So I got some clear Barboline paint at Van Waters & Rogers and it worked (still does): plain old plywood doesn't leak, crack, peel, or corrode. Now I'm thinking about a wood bath tub.

Van Waters & Rogers is a huge lab supply house. I don't know anything about them except they have a hard-bound catalog this thick full of illegal-looking equipment. They have outlets all over the western U.S.

Van Waters & Rogers Catalog
1112 pp.



Free if you justify your existence as a customer.

Van Waters & Rogers
3200
Annex
San Francisco, California 94119

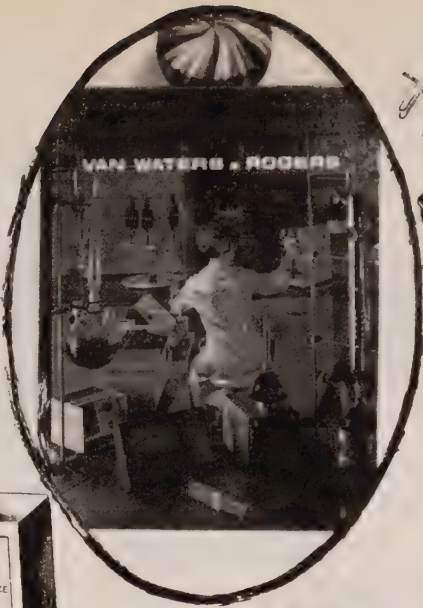

PAINT, Corrosion-Resistant, Plastic, Self-Priming, Carbol Series "K" — Provides excellent protection indoors and out against corrosive fumes, corrosive atmospheric conditions, occasional spillage of acids or alkalis. Particularly useful in the chemical, petroleum, laundry, food, beverage and similar industries. Long-lasting and economical. Simple to apply — requires no special surface preparation, and no primer, intermediate or seal coat. Stands up well under most acids and alkalis, oils, greases and alcohols. Excellent moisture resistance. Can be applied equally well to metal, concrete or wood. Brushes or sprays on.

52673-081	Black	Quart	2.45
52673-128	Clear	Quart	2.45
52673-161	Gray	Quart	2.85
52673-285	White	Quart	3.00
52674-084	Black	Gallon	6.70
52674-120	Clear	Gallon	6.70
52674-164	Gray	Gallon	8.00
52674-288	White	Gallon	8.45

THINNER — For use, only if necessary, in brush application, to make brushing easier. For use with Nos. 52673-081 — 52674-288. For spraying, one part of Carboline thinner to two parts of Carboline paint.

52675-043	Quart	1.65
52675-087	Gallon	4.35

Benzene

CORROSION-RESISTANT LABORATORY PAINTS

52673-081 — 52675-087

Bookmaking



A textbook for book designers.

Should enable anyone from author to customer to communicate intelligently about any aspect of the design or production of a book. Probably the only existent reference for someone who needs to deal with printers and publishers, and isn't quite sure he knows an offset from a castoff. Perhaps the best thing that can be said about this book is that it is beautifully designed, but by the time you finish reading it you'll probably know enough to start criticizing its design.

[Reviewed by Larry McCombs]

To reconcile the sometimes divergent needs of the various aspects of bookmaking, decide first on what should be done creatively, then modify these decisions as necessary to accommodate the practical considerations. In other words, plan the ideal first and retain as much of it as you can. This works better than any other procedure because the creative process functions best when it is free of practical considerations. The moment you accept mechanical or economic limitations, your imagination tends to freeze. Not that it merely restricts itself to the practicable—it tends to act as though the limiting walls were made of glass, and it swings in a cramped arc far short of those walls. This is a safe enough procedure, but it precludes any chance of extending the possible.

Bookmaking
Marshall Lee
1965; 399 pp.

from:
R. R. Bowker Company
1180 Avenue of the Americas
New York, N.Y. 10036

\$12.75 postpaid

The readability of a page is affected by no less than 9 factors:

- (a) typeface,
- (b) size of type,
- (c) length of line,
- (d) leading,
- (e) page pattern (which includes "margins"),
- (f) contrast of type and paper (which includes color),
- (g) texture of paper
- (h) typographic relationships (heads, folios, etc.), and
- (i) suitability to content.



PROOFREADER'S MARKS

Marginal sign	Mark in text	Meaning	Corrected text
S	Proofreading	Delete, take out letter or word	Proofreading
⊕	Legibility is the requirement of a proofreader's marks.	Delete and close up	Legibility is the first requirement of a proofreader's marks.
⊖	Symbols should be made neatly and	Insert marginal addition	Symbols should be made neatly and
⊗		Close up entirely	
⊘		Less space	
⊙		Push space down to avoid printing	
#	in line with the text to which they refer.	Add space	in line with the text to which they refer.
⊕	Place marks carefully.	Space evenly	Place marks carefully. Paragraphs may be
⊖	Paragraphs may be	New paragraph	
⊗		No new paragraph	

Zone System Manual

This invisible book contains the essence of Ansel Adams' zone system of photography distilled by Minor White, who has his own mastery. The term for the process is pre-visualization, which is looking at reality through an accurately imagined photographic print, then knowing how to make the calculations and mechanical and chemical adjustments so that the print has what you saw. It's all here.

Zone a "Zone" as a visual unit of measurement is arrived at by altering a standard exposure by one "stop" more or one "stop" less. For example all the values in a scene exposed at f/11 at 1/25 second would print one "zone" lighter than a print of the same scene exposed at f/16 at 1/25 second. (Providing

of course that the two negatives were given identical development time and the same exposure time in the enlarger.)

This "one Stop" or "one Zone" alteration, links the "zone" to the classic 1:2 exposure ratio used in photography to calibrate shutter speeds and diaphragm openings or "stops."

EXTEND PREVISUALIZATION UNTIL THE NEGATIVE IMAGE CAN BE SEEN IN YOUR MIND'S EYE

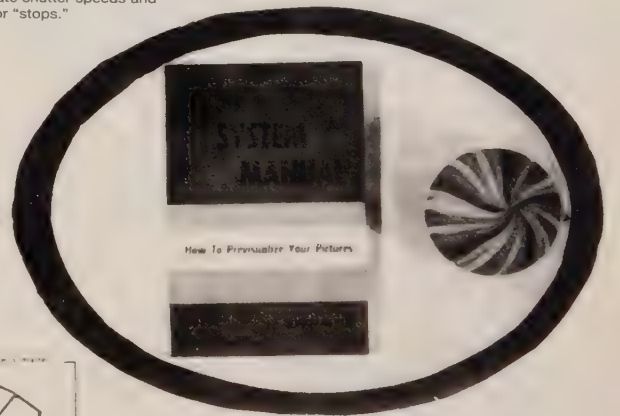
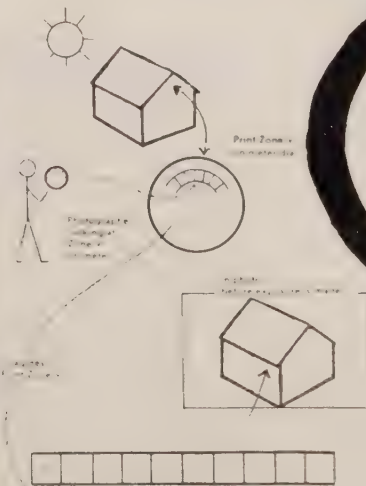

Zone System Manual
Minor White
1965; 112 pp.

\$1.95 postpaid

from:
M. J. Morgan, Inc.
280 West Street
Hightstown, N.J. 08520
or
WHOLE EARTH CATALOG

A Sculptor's Manual

This book is a well organized presentation of the basic processes behind sculpture. Detailed processes are made to seem simple, but not oversimplified; it remains obvious that a good deal of patience will be required to cast a bronze by the lost wax method. People who do not know what technique will suit them best and who want a solid footing from which to experiment, will find *A Sculptor's Manual* most useful. It encourages you to attempt the forms you have imagined, by showing you how.

The nine chapters cover plaster usage; foundry practice; flame and electric welding; plastics; cement; stone and wood; repetition casting; general construction; finishing; and surface coatings. Cross referencing, a glossary, and 27 diagrams make the book all the more usable. British sculptors will find a buyer's guide at the end of each chapter. Americans are referred to the yellow pages, Bernard Klein's "Guide to American Directories" and the "Thomas Register" (see p. 23 of the CATALOG) to find sources for materials.

At the back of the book is a section of 22 photos of finished sculpture, just enough to intrigue and egg you on without being pushy.

[Reviewed by Joe Bonner]

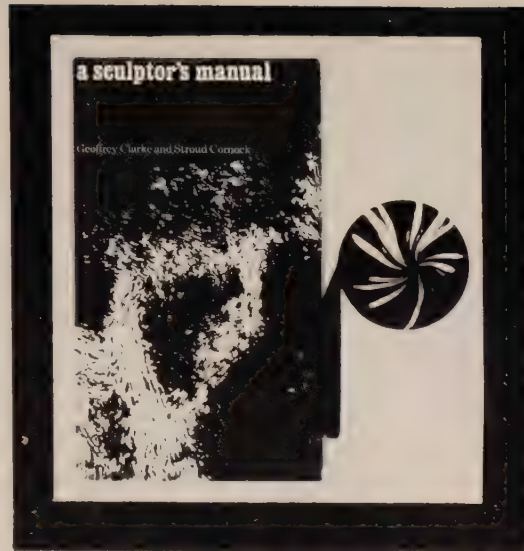

A Sculptor's Manual
Geoffrey Clarke & Stroud Cornock
1968; 158 pp.
\$8.50 postpaid

from
Reynolds Publishing Company
400 ... Ave.
New York, N.Y. 10022

temperature at which it was formed and it will revert through a sequence of forming operations back into a sheet.

Thermosets are built up with glass-fibre reinforcement over female mould surfaces and subsequently painted if required, though mass-pigmentation can be effected before lay-up.

Thermoplastics can be bent and formed when hot, either freely or by mechanical forming, e.g. they can be injected under pressure into moulds. These materials can be bonded with adhesives, welded together by high-frequency vibration, screwed over a frame or welded with hot gas and a filter rod. It is possible to vary the mass-pigmentation of various thermoplastics by laminating a screen-printed surface onto the rigid sheet.

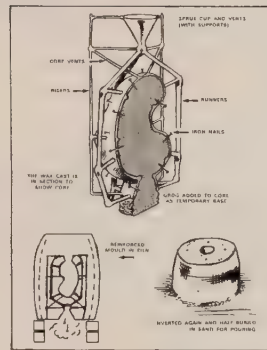

Lost Wax process or cire perdue. A lengthy and complex process. Join all wax runners, risers, etc., with a wax knuckle by modelling with a hot spatula. Reinforce grog with chicken wire. Before removal from kiln, reinforce surface with plaster and scrim. Keep sprue clear of sand, etc.

The process has changed little since the Greeks brought it to a pitch of achievement, and it is still so demanding that very few foundries exist. Their services are very costly. If you have a sculpture in clay, wax or plaster, and it is of a nature that demands faithful reproduction, there is no doubt that bronze - far denser than aluminum, cast by the Lost-Wax process - quite different from sand-casting - presents the only method of preserving the form and texture accurately.

This is an extremely complex and variable method, though large works can be cast more cheaply if it is followed up to the point at which the wax has been cored - or just to the production of the wax (without runners or core) - and the result is then given to a foundry for casting. If the foundrymen produce a bad result, however - it will be your fault.

30 Industry & Craft

Does any reader know of a thorough book - up to date - on the techniques of working with plastics?

The development of plastics has been continuing since the end of the last century and the term plastics now covers a complex of materials of which those dealt with here for a small and relatively simple part.

Firstly, there is the vast range of thermosetting plastics materials which are manufactured as liquids in two or three component parts. These are the polyesters and epoxy resins. They require reinforcement and are formed in a one-way process.

Secondly, there is an even larger range of thermoplastics, manufactured in powder or chip form and fabricated into very thin sheets which are subsequently laminated to provide whatever thicknesses may be required. They are structural materials - either flexible or rigid - and are formed under heat in a reversible process: raise a thermoplastic object carefully to the

Creative Glass Blowing

This well-illustrated and carefully written book begins with the statement "Any one can learn to blow glass." To a large extent the authors, one of whom is a professional glass blower, succeed in making that statement believable. However, the first 50 pages are concerned with the tools of the glass blower and I found myself wondering, "Yes, but can anyone learn to be a pipe-fitter, metal worker, carpenter, and electrician?" If you can do those things, there is little doubt that this book (and several hundred dollars worth of tools and related supplies) will enable you to blow glass - probably creatively.

Don't expect to take up glass blowing casually, with just this book, but if it is a hobby to which you can commit yourself seriously this book would be an excellent investment, for starters.

There is a page at the end that lists sources of tools and materials. Unfortunately, all of whom are in the East. Alas, we westerners need a special supplement, obviously.

[Reviewed by Richard Raymond]



Creative Glass Blowing
James E. Hammesfahr, Clair L. Stong
1968; 196 pp.
\$8.00 postpaid

from:
W.H. Freeman & Company
66 ... Street
San Francisco, Ca 94104
or
W.H. FREEMAN CATALOG

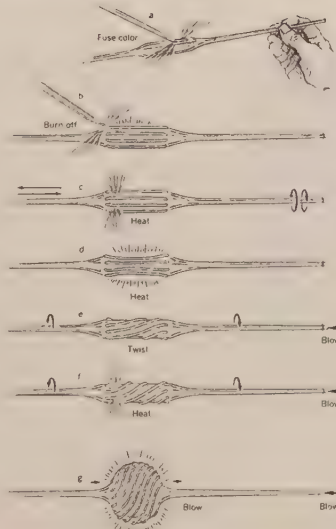
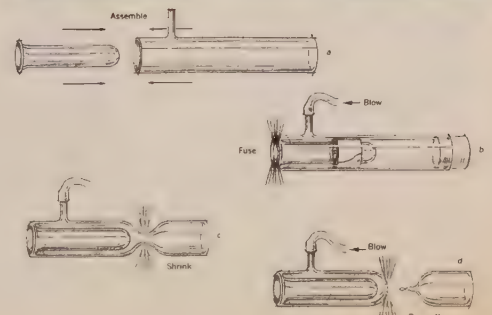

Figure 4-35



Here, then, is the first skill you must develop in the course of becoming a glass blower: the knack of rotating hot glass at a rate that precisely counteracts the force of gravity. The trick is not difficult to master if you follow a few simple rules. First, never soften more glass than you need for making a desired form. If you intend to impart a rounded shape to the end of a rod, heat only the tip. Second, never soften the material more than necessary to accomplish your objective. Obviously, stiff glass is easier to control than runny glass. Watch the work as it softens and changes form. Alter its position in the fire to take advantage of gravity, or to offset the affect of gravity, as the case may be. This is accomplished by rotating the work.



Buckskin

This is one of the best deals in the CATALOG. Buckskin in downtown San Francisco costs \$1.50 a square foot; Leather Tanning offers the same material for 90¢/sq.ft. postpaid anywhere in the U.S. The buckskin is chrome-tanned, which makes it more resistant to the effects of water than oil-tanned skin. The company also carries cowhide, elk skin, hair-on calf, etc. Orders for a dozen or more skins get 10¢/sq.ft. discount. Buckskins are generally 10-12 sq.ft. in size, calf skins smaller, elk skins larger. The shirt was made of two 12 sq.ft. buckskins.

Buckskin

Buckskin

\$.90 /sq.ft. postpaid

Hair-on-calf (clipped)

\$1.80 /sq.ft. postpaid

Hair-on-calf (unclipped)

\$1.60 /sq.ft. postpaid

Leather Tanning Company
2406a
San Francisco, California 94124



Cut Beads

In evaluating Indian beadwork, one of the first things you notice is whether the beads are cut or seed beads. Cut beads are slightly faceted so they reflect a scattered sparkling of light from the beadwork. They raise the value of the piece because (1) it is prettier, (2) the craftsman went to the extra trouble or expense to get cut beads, (3) the piece may be antique.

The single source of cut beads in America is Elliot Greene & Co. in New York. They sell a minimum of 1/2 kilo per color. Coax your bead pusher to stock up.

[Suggested by Michael Hoffman]

Cut Beads

\$12.50 per 1/2 kilo

from Elliot Greene & Company, Inc.
35 West 17th Street
New York, N.Y. 10018

Industry & Craft 31

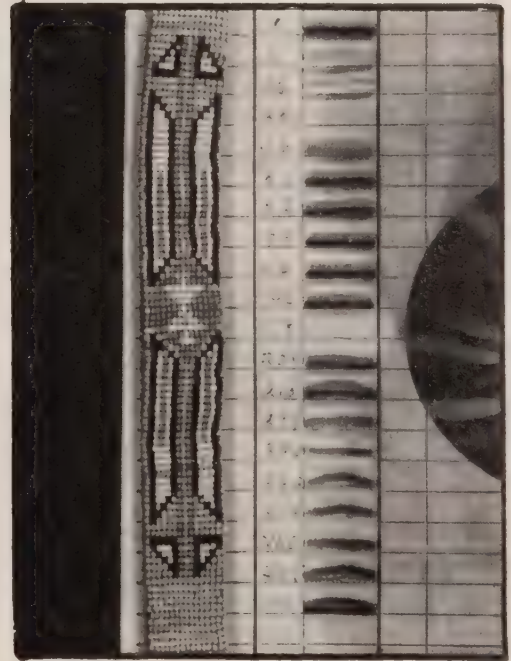

Melrose Yarns

Of the mail-order yarn catalogs that we've seen, this is the most complete, least expensive. Prices are comparable to or better than most yarn stores.

Melrose Yarns

Catalog and Sample Card

\$.50

from Melrose Yarn Company, Inc.
135 West 42nd Avenue
Brooklyn, New York 11203



Human Biocomputer

John Lilly has worked for a long time with sensory deprivation, pursuing the notion that relieving the computer (mind) of many of its environmental-survival chores frees it to attend more fully to self-investigation. Of late he's added LSD to the process and has found ways to flourish and discover within this doubly floating condition.

The paper *Human Biocomputer* is the best internal guidebook I've seen - far more practical and generalized than transcendent Eastern writings or wishful Underground notes. Though it's not the whole story by any means, it makes an open start on fresh language and powerful technique for the frontier.

An additional advantage the paper offers is the opportunity to learn and explore computers without requiring money or administrative approval. You inherited and grew everything you need, and it's free.

[Suggested by Ralph Metzner]

For example, the term 'reprogramming substances' may be appropriate for compounds like lysergic acid diethylamide. For substances like ethyl alcohol the term 'metaprogram-attenuating substances' may be useful.

I believe that by using certain methods and means some of which are presented in this work that truly talented and dedicated individuals can forge, find, and devise new ways of looking at our minds, ways which are truly scientific, intellectually economical, and interactively creative. Consider for example, the case of the fictitious individual created by the group of mathematicians masquerading under the name of "Dr. Nicholas Bourbaki."

This group of mathematicians in order to create a mathematics or sets of mathematics beyond the capacity of any one individual, held meetings three times a year and exchanged ideas, then went off and worked separately. The resulting papers were published under a pseudonym because the products of this work were felt to be a group result beyond any one individual's contribution.

The major problems of the research of interest to the author center on the erasability, modifiability, and creatibility of programs. In other words, I am interested in the processes of finding metaprograms (and methods and substances) which control, change, and create the basic metaprograms of the human computer. It is not known whether one can really erase any program.

The boundary of the brain, of course, may be considered as the limits of the extensions of the central nervous system into the periphery.

In the maximally attenuated environment (92 to 95 degrees F. isothermal skin, saltwater suspension, zero light levels, near-zero sound levels, without clothes, without wall or floor contact, in solitude in remote isolation, for several hours), the addition of LSD-25 allows one to see that all the previous experiences with "outside screens" are evasions of deeper penetration of self (and hence are "screens" in the sense of "blocking the view behind," as well as "receiving the projected images").

Human Biocomputer

John C. Lilly, M.D.
1967; 160 pp.

Inquire price (Metzner says its about \$5.00)
from:
Communications Research Institute
Mt. Mansfield, Vt. 05475

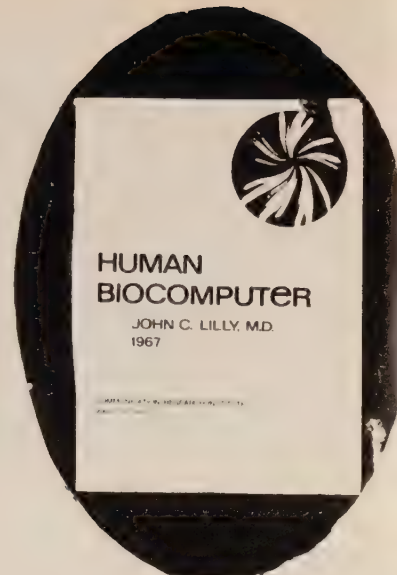

Later with higher motivational energy the subject returned to the problem of the lock, the doors and the rooms somewhat refreshed by the experiences in the other realms.

The essential features and the goals sought in the self-analysis is the metaprogram "make the computer general purpose". In this sense we mean that in the general purpose nature of the computer there can be no display, no acting, or no ideal which is forbidden to a consciously willed program. Nor is any display, acting, or ideal made without being consciously programmed.

"Mathematical transformations" were next tried in the approach to the locked rooms. The concept of the key fitting into the lock and the necessity of finding the key was abandoned and the rooms were approached as "topological puzzles." In the multidimensional cognitive and visual space the rooms were not manipulated without the necessity of the key in the lock.

32 Communications

The Mind of the Dolphin

Lilly knows that it is everybody's advantage for one kind of computer to link up with another, and that's his program with dolphins. This book reports his speculations and experiments with dolphins in recent years. Included is a thorough account by a girl, Margaret Howe, who lived alone with Peter Dolphin for 10 weeks. As usual with research on communication, everything discovered has broad implications.

Sometimes I feel that if man could become more involved in some problems of an alien species, he may become less involved with his own egocentric pursuits, and deadly competition within his species, and become somehow a better being.

We are often asked, "If the dolphins are so intelligent why aren't they ruling the world?" My very considered answer to this is - they may be too wise to try to rule the world. The question can be easily turned around, Why does man or individual men want to rule the world? I feel that it is a very insecure position to want to rule all of the other species and the vast resources of our planet. This means a deep insecurity with the "universes" inside of one's self. One's fears and one's angers are being projected on others outside of one's self; to rule the world is, finally, to rule one's inner realities.

Thus a given dolphin can carry on a whistle conversation with his right side and a clicking conversation with his left side and do the two quite independently with the two halves of his brain.

Conservatively, we estimate that the dolphin can put out ten times the sonic physical information per second that a man produces.

The information does not exist as information until it is within the higher levels of abstraction of each of the minds and computed as such. Up to the point at which it becomes perceived as information, it is signals. These signals travel through the external reality between the two bodies, and travel as signals within the brain substances themselves. Till the complex patterns of traveling neuronal impulses in the brain are computed as information within the cerebral cortex, they are not yet information. Information is the result of a long series of computations based on data signal inputs, data signal transmissions to the brain substance, and recomputations of these data.



The Mind of the Dolphin

John Cunningham Lilly, M.D.
1967; 310 pp.

\$5.95 postpaid

from:
Doubleday & Company, Inc.
50 West 23rd Avenue
Garden City, L.I., N.Y. 11531
or
WHOLE EARTH CATALOG

By long and hard work I found that the evil label "negative" should not be tied to any mode or any kind of thinking at all.

I found that bodily sources of discomfort, pain, or threat tend to program the mind in the negative mode and keep it there as long as the discomfort continues. As long as pain, even at a very low level, continues, the computer (which is one's mind) tends to program a negative pail.

Once one has been through deep experiences in tune with the vast forces of the universe, the vast forces within ourselves, we see that the need for conflict, the need for hostility, and the need for hatred become less intense. One finds the universe inside and the one outside so vast and so lonely that any other living thing that loves or shows any signs of loving is precious and close.

The human participant's assumptions, i.e., those of Margaret C. Howe in her own words are as follows:

1. Dolphins are capable of communication with man on the level of high intelligence.
2. Dolphins are not only capable of this communication but are eager for it and are willing to cooperate with man to achieve it.
3. Possibly the best way to go about establishing this communication is to set up a situation where the man (woman) and a dolphin live together as closely as possible for an extended period of time.
4. This is a long process and involves many steps, each of which must be recognized and encouraged. The attempt to communicate with a dolphin in English involves two main parts: (1) the dolphin must learn how to physically say the words, and (2) he must learn the meaning of what he is saying. These two parts may be worked out individually or simultaneously.
5. One first step is the creation and the maintenance of the mutual trust and reciprocal rewards one for the other.

Figure 1. Schema of the Levels of the Functional Organization of the Human Biocomputer

Each part of each level has feedback-control relations with each other part, indicated by the connecting lines. Each level has feedback-control with each other level. For the sake of schematic simplicity, many of these feedback connections are not shown. One example is an important connection between Levels VI and X; some built-in, survival programs have a representation at the Metaprogram Level which places a representative at the Supra-self-metaprogram Level as follows: "These programs are necessary for survival; do not attenuate or excite them to extreme values; such extremes lead to non-computed actions, penalties, illness, or death." After construction, such a Metaprogram is transferred by the Self-metaprogram to the Supra-self-metaprogram for future control purposes.

The boundaries between the body and the external reality are between Levels I and II; certain energies and materials pass this boundary in special places (heat, light, sound, food, secretions, feces). Boundaries between body and brain are between Levels II and III; special structures pass this boundary (blood vessels, nerve fibers, cerebro-spinal fluid). Levels IV through X are in the brain circuitry and are the software of the Biocomputer.

Levels above Level X are labeled "Unknown" for the following purposes: (1) to maintain the openness of the system, (2) to motivate future scientific research, (3) to emphasize the necessity for unknown factors at all levels, (4) to point out the heuristic nature of this schema, (5) to emphasize unwillingness to subscribe to any dogmatic belief without testable hard-nosed reproducible data, and (6) to encourage creative courageous imaginative investigation of unknown influences on and in human internal realities.

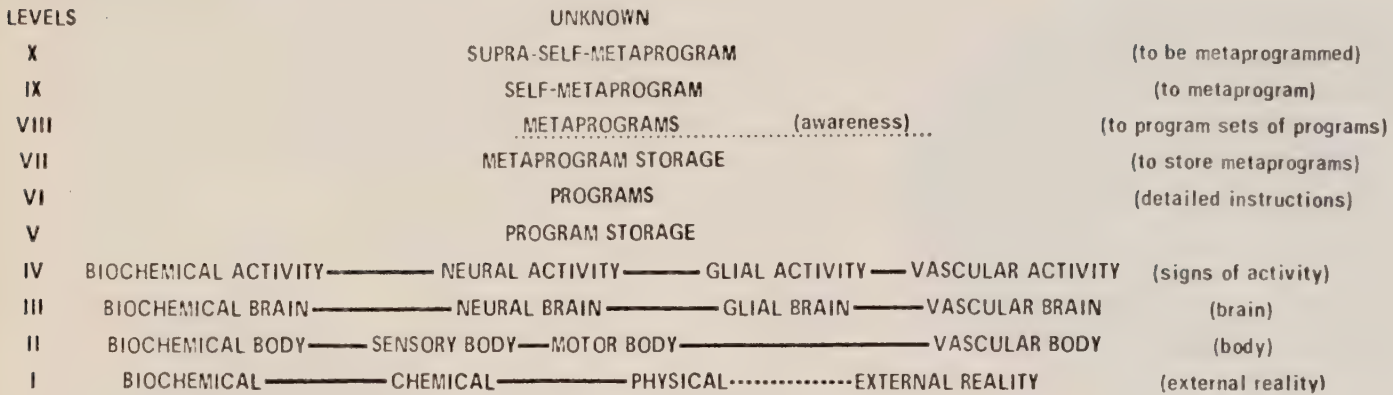

In the analysis of the effects of LSD-25 on the human mind, reasonable hypothesis states that the effect of these substances on the human computer is to introduce "white noise" (in the sense of randomly varying energy containing no signals of itself) in specific systems in the computer

The increase in "white noise" energy allows quick and random access to memory and lowers the threshold to unconscious memories ("expansion of consciousness"). In such noise one can project almost anything at almost any cognitive level in almost any allowable mode

The noise introduced brings a certain amount of disorder with it, even as white noise in the physical world brings randomness. However, the LSD-25 noise randomizes signals only in a limited way: not enough to destroy all order, only enough to superimpose a small creative 'jiggling' on program materials and metaprograms and their signals.

In the complete physical absence of other external computers within the critical interlock distance, the self-directed and other-directed programs can be clearly detected, analysed, recomputed, re-programmed, and new metaprograms initiated by the solitudinous computer itself. In the as-completely-as-possible-attenuated-physical reality environment in solitude, a maximum intensity, a maximum complexity and a maximum speed of re-programming is achievable by the self.

John C. Lilly, M.D., Human Biocomputer Programming and Metaprogramming, Miami, Communication Research Institute, 1967, Scientific Report No. CRI 0167

Information

The September 1966 issue of *Scientific American* was devoted entirely to the new technology of information. Now available as a paperback book, it is the best introduction we've seen to computer science. Articles include: "Computer Logic and Memory", "Computer Inputs and Outputs", "Systems Analysis and Programming", "Time-sharing on Computers", "The Transmission of Computer Data", "The Uses of Computers in Technology", "The Uses of Computers in Organizations", "The Uses of Computers in Education", "Information Storage and Retrieval", and "Artificial Intelligence".

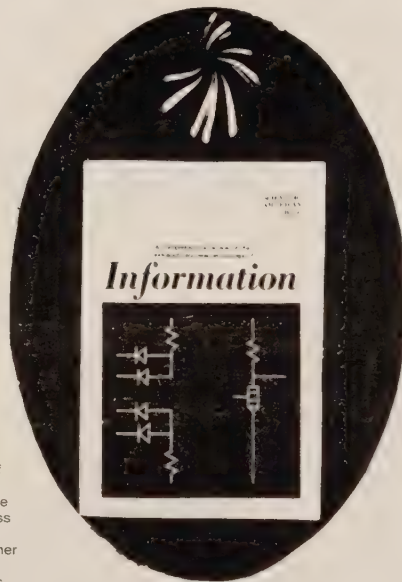

Information
1966; 218 pp.

\$2.50 postpaid

from:
W.H. Freeman & Company
660 Third Street
San Francisco, California 94104
or
WHOLE EARTH CATALOG

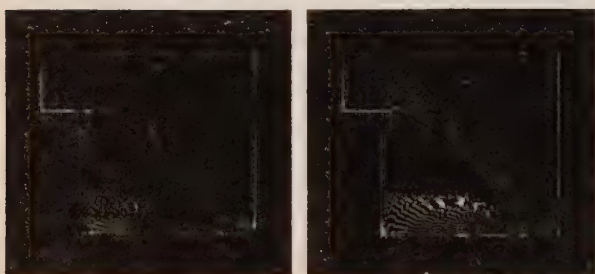
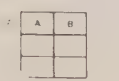
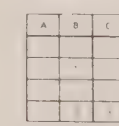
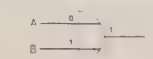
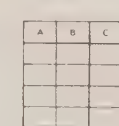
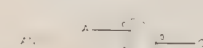
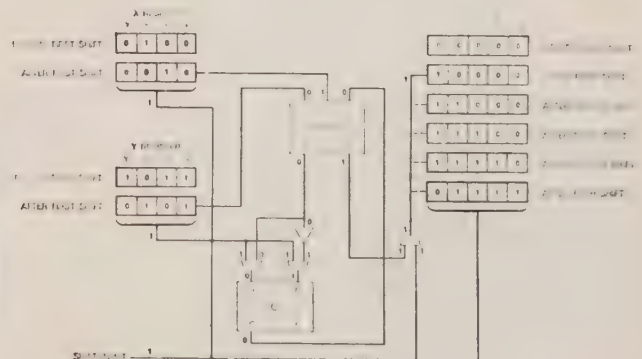

10. Simulated waterfall spills over the edge of a cliff and splashes into a pool in this computer experiment performed by John P. Shannon at the Los Alamos Scientific Laboratory as part of a study of dynamic behavior of fluids with the aid of numerical models.

9100A Calculator

The best of the new table-top number crunchers is this Hewlett-Packard machine. It is programmable, versatile, and fast – more so than its competition. Portola Institute currently is using the 9100A to help kids gain early mastery of computers – it is a superb inquiry machine.

The 9200A can do addition, subtraction, multiplication, division square root log x, ln x, ex, sin x, cos x, tan x, sin⁻¹x, cos⁻¹x, tan⁻¹x, sinh x, cosh x, tanh x, sinh⁻¹x, cosh⁻¹x, tahn⁻¹x, polar to rectangular and vice versa, co-ordinate transformations. Number range is 10-99 to 1099. The magnetic core memory has 19 registers: 3 display and 16 range. Display is decimal or floating point. Program capacity is 196 steps. Programming is done by pressing keys in the proper sequence (no special language required). Programs can be stored on wallet sized magnetic cards. Typical calculations take 2-280 milliseconds. Weight of the machine is 40 lbs, dimensions 8" x 16" x 19" deep. Reportedly the following accessories will be available soon: printer, xy plotter, input/output interface.

[Suggested by Robert Albrecht]



HP 9100A

\$4900.00 65 lbs shipping weight

from:
P.O. Box 301
Littleton, Colorado 80537

34 Communications

Cybernetics

McLuhan's assertion that computers constitute an extension of the human nervous system is an accurate historical statement. The research and speculation that led to computer design arose from investigation of healthy and pathological human response patterns embodied in the topological make-up of the nervous system. Insights here soon expanded into generalizations about communication that permitted the building of analogous electronic devices physically separate from the Central Nervous System. But they're just one artifact of these new understandings about communication. Society, from organism to community to civilization to universe, is the domain of cybernetics. Norbert Wiener has the story, and to some extent, is the story.

To predict the future of a curve is to carry out a certain operation on its past.

The central nervous system no longer appears as a self-contained organ, receiving inputs from the senses and discharging into the muscles. On the contrary, some of its most characteristic activities are explicable only as circular processes, emerging from the nervous system into the muscles, and re-entering the nervous system through the sense organs, whether they be proprioceptors or organs of the special senses. This seemed to us to mark a new step in the study of that part of neurophysiology which concerns not solely the elementary processes of nerves and synapses but the performance of the nervous system as an integrated whole.

The feedback of voluntary activity is of this nature. We do not will the motions of certain muscles, and indeed we generally do not know which muscles are to be moved to accomplish a given task; we will, say, to pick up a cigarette. Our motion is regulated by some measure of the amount by which it has not yet been accomplished.

I have spoken of the race. This is really too broad a term for the scope of most communal information. Properly speaking, the community extends only so far as there extends an effectual

transmission of information. It is possible to give a sort of measure to this by comparing the number of decisions entering a group from outside with the number of decisions made in the group. We can thus measure the autonomy of the group. A measure of the effective size of a group is given by the size which it must have to have achieved a certain stated degree of autonomy.

Thus small, closely knit communities have a very considerable measure of homeostatis; and this, whether they are highly literate communities in a civilized country or villages of primitive savages. Strange and even repugnant as the custom of many barbarians may seem to us, they generally have a very definite homeostatic value, which it is part of the function of anthropologists to interpret. It is only in the large community, where the Lords of Things as They Are protect themselves from hunger by wealth, from public opinion by privacy and anonymity, from private criticism by the laws of libel and the possession of the means of communication, that ruthlessness can reach its most sublime levels. Of all of these anti-homeostatic factors in society, the control of the means of communication is the most effective and most important.

The mongoose begins with a feint, which provokes the snake to strike. The mongoose dodges and makes another such feint, so that we have a rhythmical pattern of activity on the part of the two animals. However, this dance is not static but develops progressively. As it goes on, the feints of the mongoose come earlier and earlier in phase with respect to the darts of the cobra, until finally the mongoose attacks when the cobra is extended and not in a position to move rapidly. This time the mongoose's attack is not a feint but a deadly accurate bite through the cobra's brain.

In other words, the snake's pattern of action is confined to single darts, each one for itself, while the pattern of the mongoose's action involves an appreciable, if not very long, segment of the whole past of the fight. To this extent the mongoose acts like a learning machine, and the real deadliness of its attack is dependent on a much more highly organized nervous system.

To use a biological analogy, the parallel system had a better homeostatis than the series system and therefore survived, while the series system eliminated itself by natural selection.

We thus see that a non-linear interaction causing the attraction of frequency can generate a self-organizing system . . .

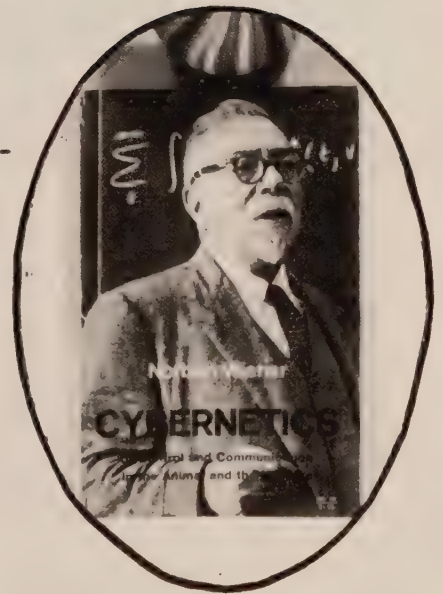

Cybernetics – or Control and Communication in the Animal and the Machine

Norbert Wiener
1948, 1961; 212 pp.

\$1.95 postpaid

from:
The MIT Press
Cambridge, Mass. 02142
or
WILEY-INTERSCIENCE CATALOG

Eye and Brain

I can't think of another book as well-made as this one. It is well designed, illustrated, and diagrammed. The writing is excellent, the subject matter important and new. The book is inexpensive. Altogether *Eye and Brain* lets you see how crappy most books are.

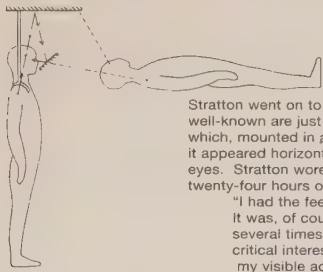

Stratton went on to perform other experiments which though less well-known are just as interesting. He devised a mirror arrangement which, mounted in a harness, visually displaced his own body, so that it appeared horizontally in front of him, and at the height of his own eyes. Stratton wore this mirror arrangement for three days (about twenty-four hours of vision) and he reported:

"I had the feeling that I was mentally outside my own body. It was, of course, but a passing impression, but it came several times and was vivid while it lasted. . . . But the moment critical interest arose, the simplicity of the state was gone, and my visible actions were accompanied by a kind of wraith of themselves in the older visual terms.

Why should the perceptual system be as active in seeking alternative solutions as we see it to be in ambiguous situations? Indeed it seems more active, and more intellectually honest in refusing to stick with one of many possible solutions, then in the cerebral cortex as a whole—if we may judge by the tenacity of irrational belief in politics or religion. The perceptual system has been of biological significance for far longer than the calculating intellect. The regions of the cerebral cortex concerned with thought are comparatively juvenile. They are self-opinionated by comparison with the ancient striate area responsible for vision.

Held found that only the active kitten developed perception, the passive animal remaining effectively blind. He thus suggested that active touch is essential to perceptual development.

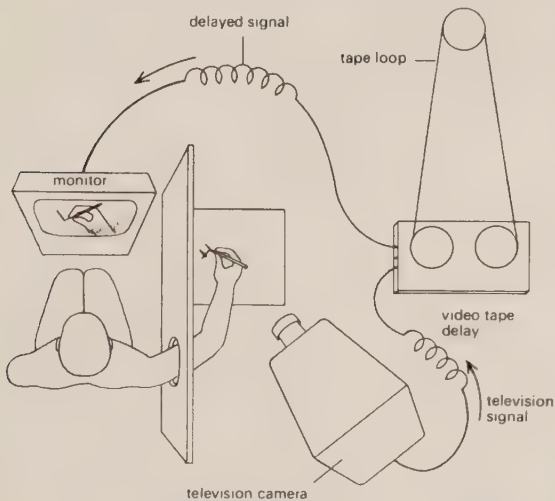

An elaboration of the television technique makes it possible to displace retinal images not only in space, but in time. Temporal delay of images is a new kind of displacement, and promises to be of the greatest importance. The method is to use a TV camera and monitor, with an endless tape loop so that there is a time-delay between the recording from the camera and the playback to the monitor. The subject thus sees his hands (or any other object) in the past; the delay being set by the gap between the Record and Play-back heads.

This situation is not only of theoretical interest, but is also of practical importance because controls used in flying aircraft, and operating many kinds of machine, have a delay in their action: if such delay upsets the skill, this could be a serious matter. It was found that a short delay (about 0.5 seconds) made movements jerky and ill co-ordinated, so that drawing became almost impossible, and writing quite difficult. Practice gives little or no improvement.

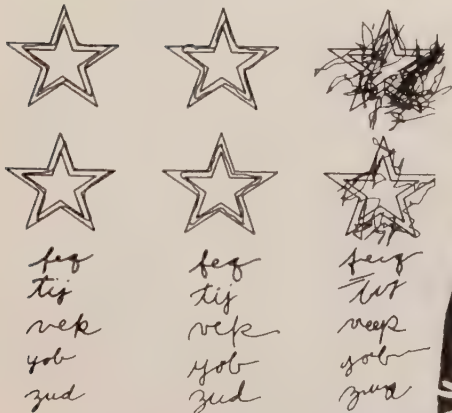

Eye and Brain - The Psychology of Seeing
R.L. Gregory
1966; 254 pp.

\$2.45 postpaid from:
McGraw-Hill Book Company
Princeton Road
Hightstown, N.J. 08520
1400 Market Road
Moberly, Missouri 63062
8700 Wood Highway
Novato, California 94947
or
WHOLE EARTH CATALOG

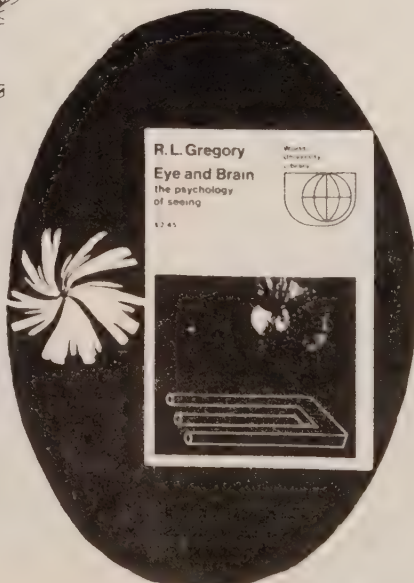

Design for a Brain

This is a reputation review. Ashby's book is found prominent in the bibliography and footnotes of every text we've seen on computers and the mind. It's technical going to read but worth it for the insights of prime work.

Finding an optimum is a much more complex operation than finding a value that is acceptable (according to a given criterion). Thus, suppose a man comes to a foreign market containing a hundred kinds of fruit that are quite new to him. To find the optimum for his palate he must (1) taste all the hundred; (2) make at least ninety-nine comparisons, and (3) remember the results so that he can finally go back to the optimal form. On the other hand, to find a fruit that is acceptable he need merely try them in succession or at random (taking no trouble to remember the past), stopping only at the first that passes the test. To demand the optimum, then, may be excessive; all that is required in biological systems is that the organism finds a state or a value between given limits.

The development of life on earth must thus not be seen as something remarkable. On the contrary, it was inevitable. It was inevitable in the sense that if a system as large as the surface of the earth, basically polystable, is kept gently simmering dynamically for five thousand million years, then nothing short of a miracle could keep the system away from those states in which the variables are aggregated into intensely self-preserving forms.

This is the learning mechanism. Its peculiarity is that the general pattern delegates part of its control over the organism to the environment. Thus, it does not specify in detail how a kitten shall catch a mouse, but provides a learning mechanism and a tendency to play, so that is the mouse which teaches the kitten the inner points of how to catch mice.

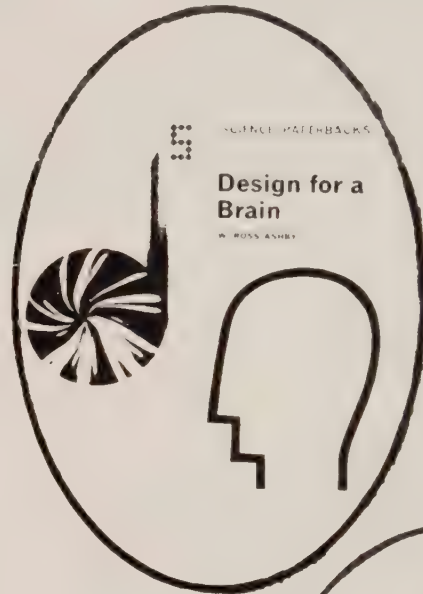

Design for a Brain
W. Ross Ashby
1952, 1960; 286 pp

\$2.85 postpaid

from:
Barnes & Noble, Inc.
105 E. 42nd Avenue
New York, N.Y. 10003
Eagle Bookstore
171 W. Madison
Chicago, Illinois 60602
or
WHOLE EARTH CATALOG

Communication 35

Education Automation

Education Automation
R. Buckminster Fuller
1962; 88 pp.

\$1.95 postpaid

from:
Southern Illinois University Press
660 Grand
Carbondale, Illinois 62903
or
WHOLE EARTH CATALOG

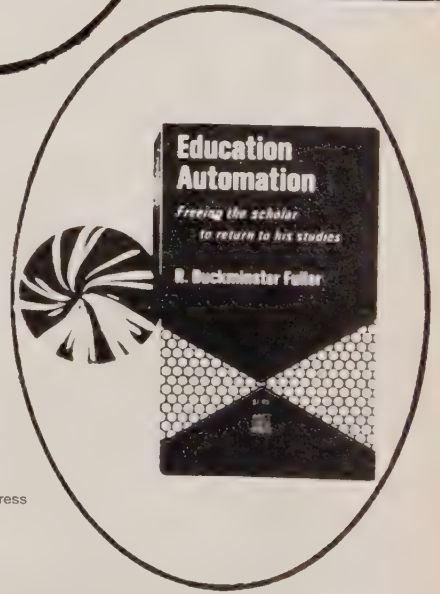

This book is listed under "Communication" rather than "Learning" because Fuller is mainly concerned with access in this book: designing ready access to comprehensive and replicable information and designing mobility as the basis of education.

I would say, then, that you are faced with a future in which education is going to be number one amongst the great world industries, within which will flourish an educational machine technology that will provide tools such as the individually selected and articulated two-way TV and an intercontinentally net-worked, documentaries call-up system, operative over any home two-way TV set.

We also find that generally speaking The geographically larger the physical task to be done, the duller the conceptual brain that is brought to bear upon the integration of the scientific discoveries and their technically realized applications. Finally, we get to international affairs, and you know what is happening today.

I would counsel you in your deliberation regarding getting campuses ready now to get general comprehensive environmental controls that are suitable to all-purposes like a circus. A circus is a transformable environment.

Intelligent Life in the Universe

Methodically blow your mind. The information in this book, mutually massaged by the American and Soviet co-authors, proceeds from superb introductions to evolutionary astronomy and biology, through a complete presentation of recent discoveries of astronomy and space science, to brilliant speculation on the parameters of inter-civilization communication. It's the best general astronomy book of recent years but that's nothing next to its impact on all the biggest questions we know.

The existence of more than one universe is impossible, by definition.

In our discussion up to this point, we have considered only interstellar radio contact among civilizations at or just slightly beyond our present state of technical advance. Yet the bulk of technical civilizations in the universe may be immensely more advanced than ours – perhaps even billions of years beyond. The Soviet astrophysicist N.S. Kardashev, an associate of I.S. Shlovskii at the Sternberg Astronomical Institute, has considered the possibility of the detection of signals from such greatly advanced civilizations. He classifies possible technologically advanced civilizations in three categories: (I) A level of technological advance close to that of the contemporary terrestrial civilization. The rate of energy consumption is about 4×10^{19} ergs sec⁻¹. (II) A civilization capable of utilizing and channeling the entire radiation output of its star. The energy utilization would then be comparable to the luminosity of our Sun, about 4×10^{33} ergs per second. In Chapter 34, we will consider a specific proposal for the harnessing of such power. (III) A civilization with access to the power comparable to the luminosity of an entire galaxy, some 4×10^{44} ergs per second.

Taken at face value, the legend suggests that contact occurred between human beings and a non-human civilization of immense powers on the shores of the Persian Gulf, perhaps near the site of the ancient Sumerian city of Eridu, and in the fourth millennium B.C. or earlier. There are three different but cross-referenced accounts of the Apkallu dating from classical times.

Almost any other of the many accounts of alleged contacts of human beings with the crews of flying saucers – accounts which regale the flying saucer societies – follow the same pattern and stress the same points. The extraterrestrials are human, with few even minor physical differences from local cosmetic standards. (I know of no case of Negro saucerians, or Oriental saucerians, reported in the United States; but there are very few flying saucer reports made in this country by Negroes or by Orientals.)



Hardcover edition

Intelligent Life in the Universe

I.S. Shklovskii and Carl Sagan
1966; 509 pp.

\$9.95 postpaid

from:

Holden-Day, Inc.
500 Sansome Street
San Francisco, California 94111

or  postpaid

Delta Books
c/o Montville Warehousing Co., Inc.
Changebridge Rd.
Pine Brook, N.J. 07058
900 Pratt Blvd.
Elk Grove Village, Illinois 60007
1104 S. Lawrence Street
Los Angeles, Calif. 90021
or
WHOLE EARTH CATALOG

But how can a natural satellite have such a low density? The material of which it is made must have a certain amount of rigidity, so that cohesive forces will be stronger than the gravitational tidal forces of Mars, which will tend to disrupt the satellite. Such rigidity would ordinarily exclude densities below about 0.1 gm cm^{-3} . Thus, only one possibility remains. Could Phobos be indeed rigid, on the outside – but hollow on the inside? A natural satellite cannot be a hollow object. Therefore, we are led to the possibility that Phobos – and possibly Deimos as well – may be artificial satellites of Mars.

"Well, ladies and gentlemen," Struve concluded, "it was pretty dull on Epsilon Eridani and Tau Ceti eleven years ago."

With 10^{11} stars in our Galaxy and 109 other galaxies, there are at least 10^{20} stars in the universe. Most of them, as we shall see in subsequent chapters, may be accompanied by solar systems. If there are 10^{22} solar systems in the universe, and the universe is 10^{10} years old – and if, further, solar systems have formed roughly uniformly in time – then one solar system is formed every $10^{16} \text{ yr} = 3 \times 10^7$ seconds. On the average, a million solar systems are formed in the universe each hour.

The McGraw-Hill Encyclopedia of Space

Merry Christmas? A big candy-colored multi-national compendium of Earth's effort to get its rocks off. If the cost gets you, wait eight months until it's remaindered.

The McGraw-Hill Encyclopedia of Space
1968; 831 pp.

\$27.50 postpaid

\$23.95 postpaid before January 1, 1969

from:
McGraw-Hill Book Company
Princeton Road
Hightstown, N.J. 08520
Main Road
Mpls., Missouri 63062
8171 Redwood Highway
Novato, California 94947

The information contained in a single human sperm cell is equivalent to that of 133 volumes, each of the size and fineness of print of Webster's Unabridged Dictionary.

So, by an interesting coincidence, the distances between the stars in interstellar space, relative to their diameters, are just about the same as the distances between the atoms and molecules in interstellar space, relative to their diameters. Interstellar space is as empty as a cubical building, 60 miles long, 60 miles wide, and 60 miles high, containing a single grain of sand.

Radio astronomers may be interested to know that the so-called "brightness temperature" of the Earth at television wavelengths is some hundreds of millions of degrees. This is 100 times greater than the radio brightness of the sun at comparable wavelengths, during a period of low sunspot activity.

▽ An advanced technical civilization is trying to communicate with us. But how can we possibly understand what they are saying? They are not likely to speak English or Russian. They have had a different evolutionary history. They are on a planet with perhaps an entirely different physical environment. Their thought

Decode this:

```
11110000101001000011001000000010000010100
10000011001011001111000001100001101000000
00100000100001000010001010100001000000000
00000000001000100000000001011000000000000
0000001000111011010110101000000000000000
0000100100001110101010100000000101010101
0000000001110101010110101100000001000000
000000000010000000000000001000100111111000
00111010000010110000011100000001000000000
10000000010000000111110000001011000101110
100000001100101111010111100010011111001
0000000000011111000000101100011111100000
10000011000001100001000011000000011000101
001000111100101111
```

FIGURE 30-1. A hypothetical interstellar message due to Frank Drake. The 551 zeros and ones are representations of the two varieties of signals contained in the message. The problem is to convert this sequence of 551 symbols into an intelligible message, knowing that there has been no previous communication between the transmitting and receiving civilizations.

into this:

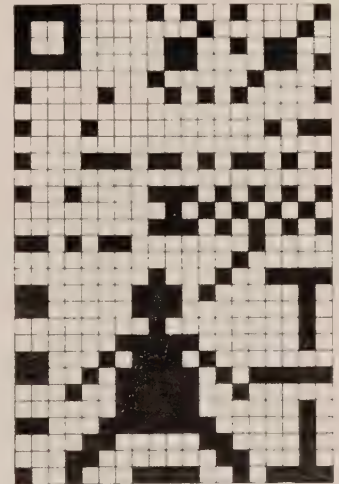

Now decode this for physiological, astronomical, chemical, mathematical, social, historical, and linguistic information.

36 Communications

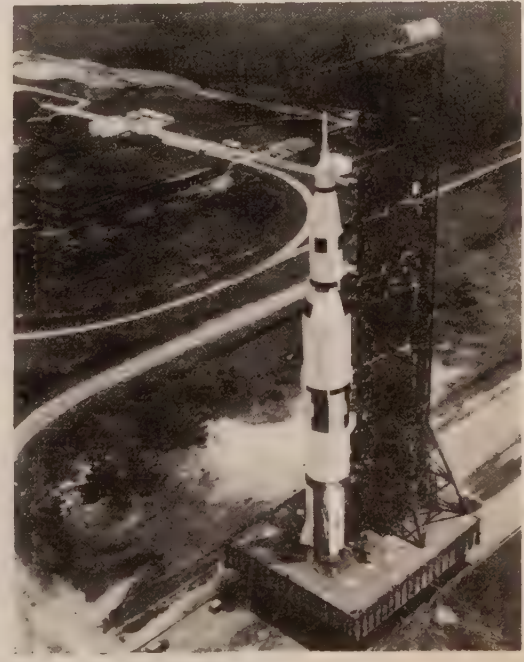

Lafayette and Allied Catalogs

Quantities of gear, Plug in, link up, incorporate.

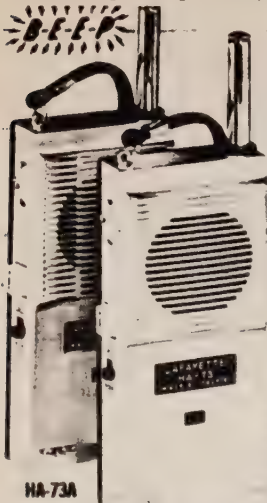

VECTOR ETCHED CIRCUIT KIT

Designed for making low cost etched circuits with the least amount of bother. Circuit can be sketched on grid layout paper provided. Once best circuit is found, Vectorsist can be used to transfer circuit to copper-clad board. Board is then put in bag containing chemical solution and agitated. Circuit takes less than 10 min. to etch. Kit includes two 1/2x6 1/2 phenolic boards; one sheet Vectorsist with assorted pad layouts, lines, circles, and connector patterns; etching chemical; grid layout paper; "practice" copper-clad pieces.



2 CHANNEL 7-TRANSISTOR SUPERHET CB WALKIE TALKIE HA-73A

- Built-in Call Alert
- Powerful Push-Pull Audio
- Battery Eliminator Jack

New power boost reflex circuit utilizes 7 transistors to achieve higher sensitivity for extended range. 2-channel operation permits greater flexibility. Call alert system sends or receives a pleasant alerting tone for convenient calling. Also features Battery Eliminator Jack for 117 Volts AC operation with optional battery eliminator. Case features beautiful die-cast chrome high-lighted front panel. Supplied with carrying strap, telescoping antenna, battery, and plug-in crystals for channel 9. Size: 5 1/2 x 1 1/4 x 2 3/4". Imported. Shpg. wt., 3 lbs. Net ea. \$15.95

2 CHANNEL 7-TRANSISTOR SUPERHET WITH CALL ALERT

No License Required
FCC Regulation Part 15
496 Lafayette Cat. No. 690

15.95 Each

Heathkit

Between readymade and do-it-yourself is do-it-yourself: Heathkit. It's good electronic equipment of a wide variety. (Current catalog lists Servo Chart Recorders, Analog Computers, Combo Organs.) Assembling yourself saves 25-40%, plus education, minus time.

[Suggested by Arthur Brand]

Heathkit Catalog Free

1969: 115pp.

from: Servo Products Corporation
167
Southfield, Michigan 48085

Heathkit Visual-Aural Signal Tracer . . . Speeds Trouble-shooting

• Ideal for trouble-shooting transistor & tube-type AM receivers & audio equipment • Traces RF, IF, and audio signals • Locates troublesome noisy or intermittent components • Convenient audio/RF probe with switch • Doubles as a test amplifier or speaker

A QUICK, SAFE WAY TO TROUBLE-SHOOT TRANSISTORIZED CIRCUITRY . . . applies no voltage to circuit under test. Safe for delicate transistor circuits easily damaged through ordinary vacuum tube testing procedures. And even the minute signals of phono pickups, etc., can be checked out, since the IT-12 features a high-gain amplifier with adjustable level control. A worthwhile investment for time-saving test facilities.

Kit IT-12, 6 lbs. \$26.95

Export model available for 115/230 VAC, 50-60 Hz; write for prices.

IT-12 SPECIFICATIONS—Power supply: Transformer operated. Power requirements: 117 volts 50/60 Hz AC. 25 watts. Tube complement: 12AX7, 12CA5, 16Z9. Speaker: 3 1/2" PM. Probe and test leads: 4" input lead for RF and audio with switch; probe body, 2-3" panel test leads with alligator clips. Dimensions: 4 1/2" W x 7 1/2" H x 4 1/2" D.



Practice your guitar playing in private . . . only you can hear when you use this handy little unit. Or use two pairs of headphones so just you and your teacher can hear your playing. The all-transistor circuit is powered by a miniature 9 v. battery (not included) which will last up to 60 hours. This compact amplifier plugs directly into your guitar and will drive one or two pairs of stereo or monophonic headphones. Tone and volume may be varied by your guitar controls. The amplifier automatically turns on as you plug it into your guitar. Build it in one evening.

Kit TA-58, 2 lbs. \$11.95



GW-22A
\$56.50

Kit TA-58
\$11.95

New Heathkit Guitar Headpiece Amplifier For Private Practice and Instruction

Modern Business Forms

This item is listed in response to queries from friends and correspondents who like the WHOLE EARTH CATALOG stationary and want some. Drawing Board has a good range of inexpensive and untroublesome business forms, personalized, but not pretentious.

[Suggested by Richard Raymond]

Modern Business Forms Catalog

47 pp.

Free

from: Drawing Board, Inc.
1000 Mount Row
Dallas, Texas 75221

WINDOW ENVELOPES (ITEM EV3-G)
Especially designed for use with Note-O-Gram III and Message Letter III on the next page. This envelope matches your letter forms in color, layout and type style giving your correspondence a distinctive look that gets attention and quick results.

Price Schedule
Prices include personalizing in type style shown or with your mounted cut. If we must make cut, add \$6.50 and include clear copy of desired artwork.

ITEM	500	1000	2000	3000	4000	5000
N3-R73 Note-O-Gram III	\$14.95	26.75	47.60	65.85	82.00	97.50
EV3-G						
Note-O-Gram III Envelope	\$ 8.85	13.85	23.10	34.50	45.30	55.75

A distinctive new design: NOTE-O-GRAM III

Get out twice as much correspondence with this modern, efficient 3-part letter form that eliminates addressing envelopes and gives both the sender and recipient copies of every message and reply.

Proven in thousands of offices across the country. Note-O-Grams are perfect for all routine correspondence. They always get attention and bring fast replies.

Easy as A-B-C to use
A: Write or type your message on the white part and snap out the yellow copy for later follow-up. B: Fold the completed message just once and slip into a standard #10 window envelope. There's no addressing of envelopes needed, a real time saver. C: The recipient replies on the white part and keeps the pink copy. This gives both parties the completed message on one sheet of paper.

Eico 70-Watt Stereo Phono System
Separately, \$315.80. Delivers first-rate performance at a low price. Factory-assembled, ready to plug-in-and-play Eico "Corina" 3070 70-Watt Solid-State Stereo Amplifier boasts silicon transistors. Includes walnut finish metal case. Garrard Synchro-Lab SL55 4-Speed Automatic Turntable has oversize platter, cueing feature. With base, Shure M32E Stereo Cartridge with elliptical diamond stylus. Two Allied 3005A 3-Way Walnut Speaker Systems with 10" woofer, 6" midrange, 3 1/2" tweeter. With cables hi-fi booklet. Shpg. wt., 65 lbs. 13 C 0349 D4U. \$19 Monthly 249.25

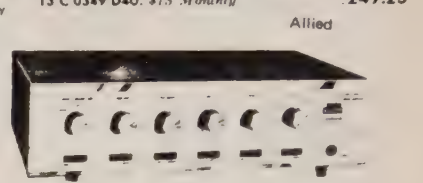

Allied Catalog 1969: 535 pp.
Free from: Allied Electronics, Inc. 100 Western Avenue Chicago, Illinois 60680

LAFAYETTE VARIABLE TUNING CONDENSER FOR CB & 10 METER RIGS
• Used in Famous Lafayette HE-20A and HE-15A Transceiver
A single ganged, variable tuning condenser offering unlimited possibilities to the experimenter, ham, and hobbyist in building Citizen Band Transceivers and 10 Meter rigs. This condenser is used by Lafayette engineers in their famous HE-20A and HE-15A Transceivers. The unusually fine vernier action of the tuning shaft allows for the very precise adjustment needed to select the closely spaced channels of the 27 MHz Citizen's Band frequencies. Rotates thru a full 180°. Single ganged, having a shaft with an overall length of 1 1/4 inches. Can be top or front panel mounted. Well constructed with a minimum capacity of 6.5 mmf., and a maximum capacity of 13 mmf. Dimensions 1 1/2 x 1 1/4 x 1 1/4 inches excluding shaft. Shpg. wt., 3 oz. 32 T 0917 Net 1.95



Kit IT-12 \$26.95

Use Heath's Free Technical Consultant Service—Write Them On Any Kit Subject

5-Channel, 5-Watt CB Transceiver . . . Choice Of Fixed Or Mobile

• 5-crystal-controlled transmit & receive channels • Superhet receiver with RF stage • Built-in squelch & automatic noise limiter • Push-to-talk microphone • Easy to build
A HOST OF OPERATING CONVENIENCES like 5 crystal-controlled transmit and receive channels . . . sensitive superhet receiver with RF stage . . . built-in squelch and automatic noise limiter . . . built-in speaker plus external connectors for adding an extra speaker if desired. Includes PTT microphone, power cable and crystals for one channel (specify frequency). Choose the AC model for "fixed," and the DC version for "mobile" operation. Choose them both and save an extra 5%. Use must comply with FCC regulations.

Kit GW-22A (117 v. AC), 13 lbs. \$56.50
Kit GW-22D (6 or 12 v. DC), 13 lbs. \$58.50
GENERAL DESCRIPTION—Receiver: 5-tube superheterodyne with RF stage, crystal-controlled, up to 5 of the 7 channels as determined by the particular crystal(s) installed. Sensitivity: 1/2 microvolt for a 10 dB signal-to-noise ratio. Transmitter: 5-watt output per channel, 5-watt total. Nominal power requirements: 117 v. AC, 25 watts. 50/60 Hz AC, 50 watts. GW-22D: 6 volts DC, 8.0 amperes; 12 volts DC, 4.5 amps. Dimensions: 10 1/2 x 6 1/2 x 9 1/2" W.



Accurate, specific information on what's new in equipment, techniques, standards, and the attitudes of technicians using them. Also gossip and news about who's doing what where. Covers all aspects of professional filmmaking from Hollywood Super Panavision 70mm to 8mm educational loops.

The ads, fully as important as the text, are mouthwatering for those with an appetite for Eclairs and such.

If you read it regularly you'll never need Baddeley - you'll know how it's really done. Often the information is directly and simply usable; sometimes it stimulates visions of the super-cinema of the future. When in school I consulted back issues for a psychology paper on perception. The articles are really interesting and, best of all, there is no film criticism, so you avoid all those negative emotions.



(Suggested by Gordon Ashby
Reviewed by Sandra Tcherepnin)

For the 16mm film-maker who can't afford the real thing—a creditable substitute set-up to aid in cutting sync-sound film

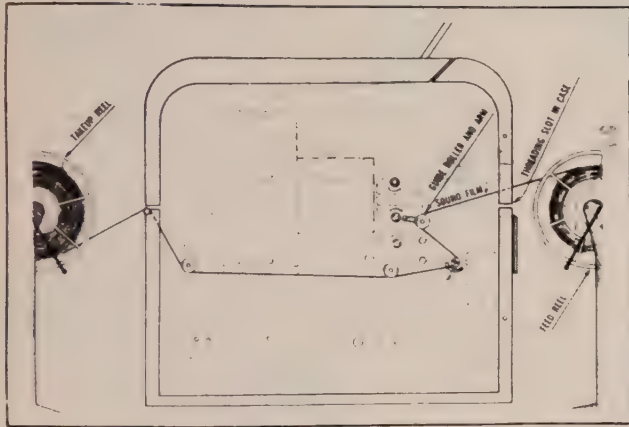

Design for using the recording pattern necessary in order to use the Bell & Howell Model 203 in a sound studio. Operational details are explained in the text of the book. The recording guide roller mounted on a metal axle is attached to the chassis of the projector using the front set screw. The motor is mounted on a special bearing assembly of bearing in 3,000 rpm. See the text for details.

39 Communications **"THE NEW DIMENSION"**

Several classic methods for creating Special Effects—with and without an Optical Printer

8mm is on the verge, and by verge, I mean it is about 8 1/2 months pregnant, of delivering to us a great big, brand new opportunity to mold and shape something entirely new.

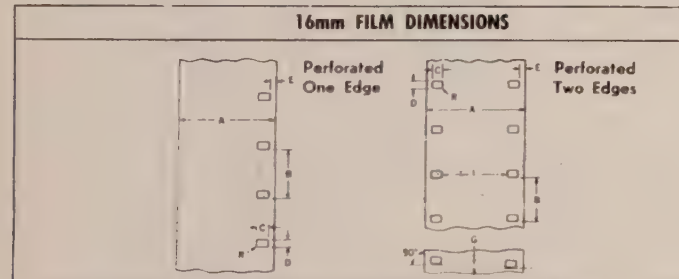

FILM	ASA STAND.	FILM DIMENSIONS (Inches)									
		A	B	C	D	E	G	I	L*	R	
16mm 2R-3000	PH22.5	0.629	0.3000	0.0720	0.0500	0.036	0.001	0.413	30.00	0.010	
16mm 1R-3000	PH22.12	0.629	0.3000	0.0720	0.0500	0.036			30.00	0.010	
16mm 1R-2994	PH22.109	0.628	0.2994	0.0720	0.0500	0.0355			29.94	0.010	
16mm 2R-2994	PH22.110	0.628	0.2994	0.0720	0.0500	0.0355	0.001	0.413	29.94	0.010	

*This dimension represents the length of any 100 consecutive perforation intervals

For the film-maker on a budget—a way to make equipment serve a double-duty purpose

Anyone who edits film may be interested in the mechanical 16mm system I use. It is simple and economical

American Cinematographer Manual

Indispensable data book, used by American cinematographers. Expensive, because it is absolutely comprehensive, up to date, from Hollywood, and has no competitors

American Cinematographer Manual
Joseph V. Mascelli, A.S.C., ed.
604 pp.

\$12.50 postpaid

from
The American Cinematographer Manual
P.O. Box 2230
Hollywood, California 90028
or
WORLDWIDE CATALOG

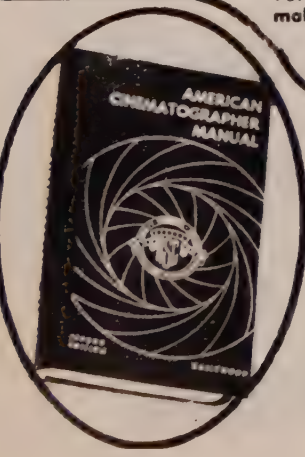

More than 600 pocket-size pages of concise, practical, informative text, tables, charts, diagrams, drawings and listings of all the latest production equipment and filming techniques in use today!
Key word printed on the edge of every right-handed page provides INSTANT INDEX for quickly locating desired data!

\$6.00 for one year (monthly)

from
American Cinematographer
1000 North Orange Drive
Hollywood, California
90028



Question: In what unusual ways did you utilize the telephoto lenses you mentioned earlier?

Wexler: The 400mm lens was especially useful in the polo sequence because it focuses down to 15 feet. We were able to focus on something very sharply at 15 feet and then, by throwing the focus back to something at infinity, make the foreground object literally disappear. We used that effect, forward in reverse, several times. For example, the opening scene of the polo sequence is a shot of thundering horses' hooves, over-cranked for slow motion, with heat waves shimmering through the frame. Then, as they come toward you, the focus goes to a polo ball which literally fills the frame, and there's a sharp "whack" as the mallet drives it out of frame. It makes a pretty good beginning for the sequence.

On the streets and in the buildings of Boston, a Hollywood motion picture crew films sequences for a high-style tale of bank robbery for kicks

Try not to be put off by the word "documentary."

This is a book for times when you are starved for some lean and specific information. It covers all conventional aspects of filmmaking: subtle items, which can really best be learned by the experience of seeing and working on films (use of dissolves, effect of different lens lengths, etc.); necessary conventions, like systems of marking workprints, and technical facts about equipment; and the hundreds of little hints and tricks, some whimsical some incredibly mundane, which technicians have hit upon by trial, error and inspiration over the years. All of these are discussed in the same thorough, detached, insensitive way. But at least the basic information is there so you can get it if you need it. This book will not help you to learn filmmaking - you'll have to bring along the enthusiasm and involvement - so start filming and then use it when you have to.

(Reviewed by Sandra Tcherepnin)

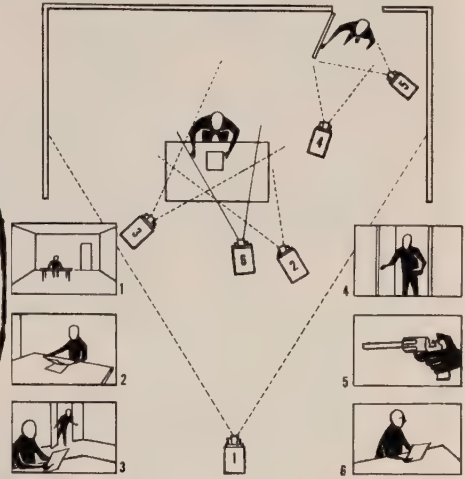

CONVENTIONAL CUTTING ROOM SIGNS. 1. Unintentional joint. 2. Unintentional joints made to insert a patch replacing a damaged portion of work-print. Ignore when matching master. 3. Extended scene. 4. Fade out and fade in. 5. Dissolve. These signs are drawn on the work-print by the editor, usually with a Chinagraph pencil, to guide the person matching the master.

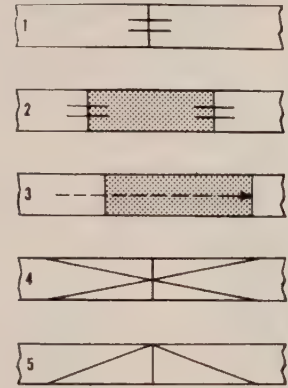

"The Film Works" in San Francisco

Groot Productions and Patterson & Hall have formed "The Film Works," San Francisco's newest and possibly most complete establishment for "source-in-depth" creative film production for television, business and education. Offices are at 425 Bush Street, San Francisco, Calif. 94108, telephone 362-5230.

The Technique of Documentary Film Production

1963; 268 pp.

\$10.00 postpaid

from
Communications Arts Books
Harcourt Brace, Publishers, Inc.
157 West 40th Street
New York, N.Y. 10022

If we see a man in medium shot and then take a closer look at him in close-up, he must be in the same position in both shots - or, to be more precise, he must be in the same position at the end of the medium shot as when we cut to him at the beginning of the close up. In real life this would automatically be so; when we film him we must somehow ensure that it is so despite the fact that, in changing our lens or camera position, there has been a lapse of time. On the face of it, this point appears obvious. It is all the more surprising, therefore, that many beginners fail to appreciate it and assemble their shots with serious continuity errors between them, thinking that the audience will not be bothered by them.

Avoiding Paper Rustle

There is, for instance, that very basic requirement of ensuring that the turning of pages or the rustling of the script is not picked up by the microphone. This is usually got around by mounting the pages of the script separately on cardboard. There is still the problem of how to attach the sheets to the boards. Rubber bands are commonly used, but they can become caught in the adjacent board and emit a loud "twang"! Paper clips are an alternative, but there is a great tendency for one board to become attached beneath the clip on the next just at the moment when it is necessary to move quickly to a fresh page. A possibility is to use an adhesive such as Cow gum, but this may take longer. An ingenious alternative is to type the script on blotting paper which will not, of course, rustle. The drawback here is that it is not easy to take a carbon copy when typing on blotting paper - unless the blotting paper is the carbon copy, in which event the commentator may not find it clear enough to read.

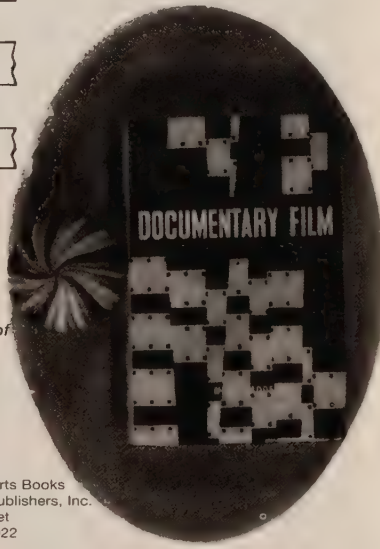

The Techniques of Television Production

I'm coming to believe that good how-to writing mostly depends on good diagramming. Millerson has mastered that, so you're inclined to believe that he knows his television. Certainly he covers the ground in a thorough fashion: studio layout, TV picture and camera, TV lighting, sound, film reproduction, sets, make-up, organization, imagery, camera control, editing, sound composition, production method, titling, effects, and color. The book can make a more critical viewer of you. Or it can give you some skill to go with the power when you demand and get some control of the half-hour educational program about your scene.

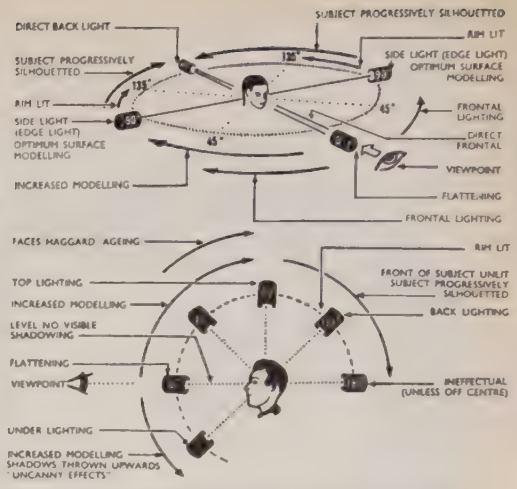
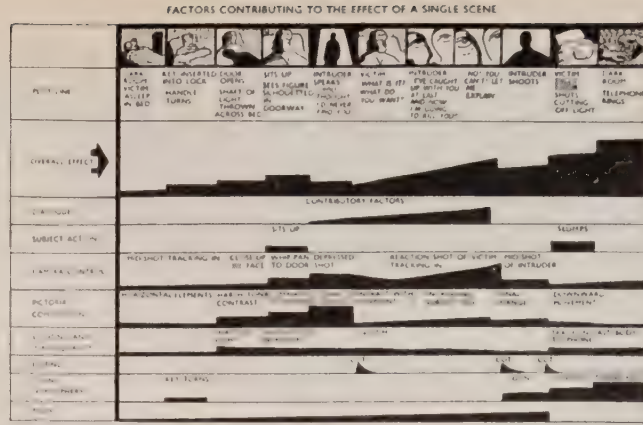

INSTRUCTIONS TO SWITCHER (vision mixer)

Instructions	Meaning
Take one: Cut to One: Cut One	Switch to Camera 1's picture.
Fade-up Two Stand by to fade Two: Ready to fade Two Fade: fade out: fade to black	Turn Camera 2's video-fader up from zero to full. Prepare to fade Camera 2's picture out.
Stand by to mix: dissolve Two Mix to Two: dissolve to Two	Turn transmitted camera's video-fader down from full, to zero. Warning before mixing-cue. Mix from present camera being transmitted, to Camera 2's picture. Warning before superimposition-cue.
Superimposing Three: ready to super Three Superimpose: add Three	Fade Camera 3's picture up, adding it to existing sources.
Take Two out: lose Two	Remove (usually fade) Camera 2's picture from transmission; leaving the rest.

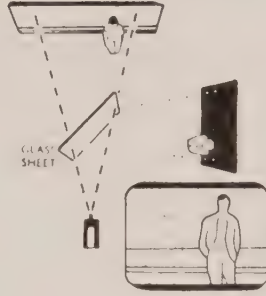

The Technique of Television Production

Gerald Millerson
1961; 1968; 440 pp.

\$7.20 postpaid from
Communication Arts Books
Holt Rinehart & Winston, Publishers Inc.
100 Madison St.
New York, N.Y. 10016



CROWDS can be simulated by using selective viewpoints (left) and carefully positioned subjects crowded together along the lens axis (centre). Also by augmenting subjects with a background of a crowd scene (moving back-projection, photo-mural, painted cloth) or using dummy or cut-out foreground figures (right).

Communications 39

Auto Repair Manual

Said to be the standard of the business, Chilton's Auto Repair Manual comes out yearly in the Fall (1969 is just out), but it covers American cars since 1960 (including Volkswagen). Covers indeed: in addition to sections on trouble shooting and repair of various units (alignment, brakes, carburetor, clutch, starter, steering, suspension, etc.), there is about 30 pages on each make of car (37 in all). If you're not interested in Detroit, Chilton publishes individual manuals authored by Harold T. Glenn on foreign cars, VW (\$3.95), trouble shooting (\$1.95), as well as a non-Glenn "Motorcycle Repair and Tune-up Guide" (\$3.95). [Hey, would somebody out there mind telling us the difference between Glenn's Auto Repair Manual (\$9.95) published by Chilton, and Chilton's Auto Repair Manual (\$11.00)?]

[Suggested by Jay Baldwin.
Reviewed by Know Nothing]

JUMPING OUT OF HIGH GEAR

- Misalignment of transmission case or clutch housing
- Worn pilot bearing in crankshaft
- Bent transmission shaft
- Worn high speed sliding gear
- Worn teeth in clutch shaft
- Insufficient spring tension on shifter rail plunger
- Bent or loose shifter fork
- End play in clutch shaft
- Gears not engaging completely
- Loose or worn bearings on clutch shaft or main shaft.

STICKING IN HIGH GEAR

- Clutch not releasing fully.
- Burred or battered teeth on clutch shaft.
- Burred or battered transmission main shaft.
- Frozen synchronizing clutch
- Stuck shifter rail plunger
- Gear shift lever twisting and binding shifter rail.
- Battered teeth on high speed sliding gear or on sleeve.
- Lack of lubrication.
- Improper lubrication.
- Corroded transmission parts.
- Defective main shaft pilot bearing

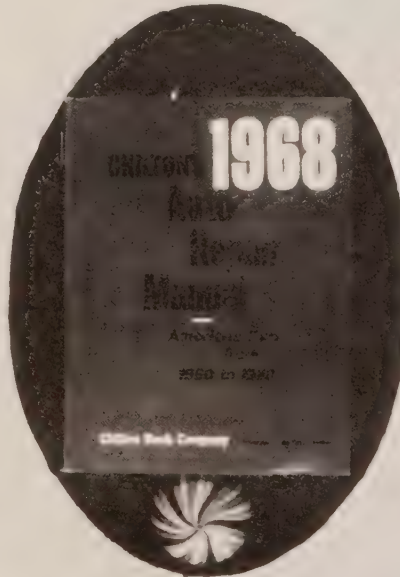

from
Chilton Book Company
Automotive Service Dept
7300 York Road
Philadelphia, Pa 19106

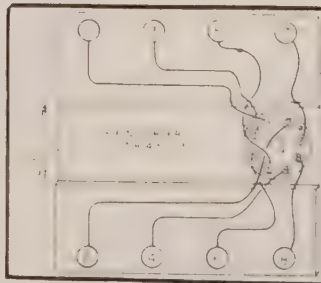
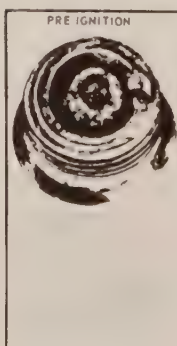
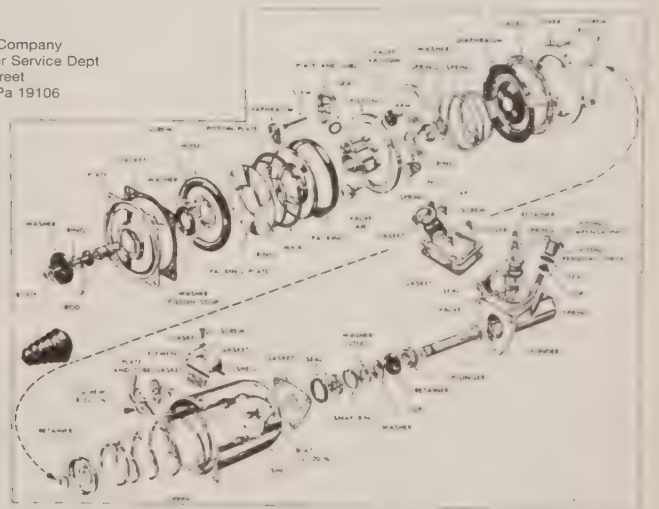

Firing Order

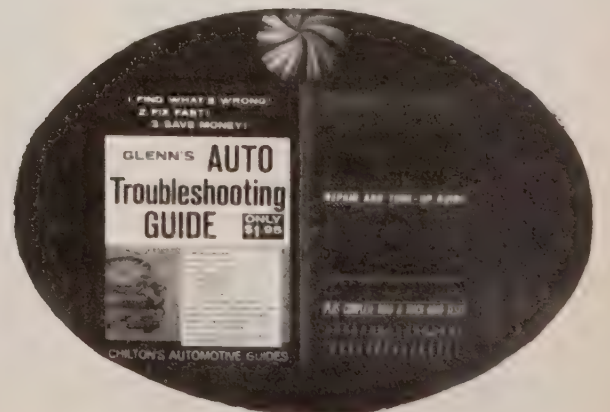

Books

What we have here is the first hip trade journal. "Books" is a scruffy newspaper made from somewhere inside the world of publishing. It pirates good stuff from new and interesting books almost as baldly as the CATALOG, and it revels in downtown gossip of who's happening. Good source of news about the intellectual wing of the current political-theatrical upwelling.



"Ho Chi Minh's Daughter" — "I have learned my English in bed. I mean it. Because I use to read many books, in bed. Because I use to listen to what my clients say, in bed." — is at last being published.

VIA I. Ecology in Design: The Student Publication. Selection of photographs prepared by graduate school of Fine Arts of the U. of Pennsylvania. Grossman \$5.00.

Birth of a Notion

Books Jerome Agel, ed.

\$3.00 for one year (monthly).

111 Avenue
K, N.Y. 10022

Books
EXPLORE

The seminal book of 1969 will be Alvin Toffler's "Future Shock," published by Random House. No firm publication date has been set.

Future shock is a time phenomenon, the dizzying psychological shock suffered by people when they are forced to adapt and re-adapt repeatedly to an accelerating pace of changes in society. Hippies, Mr. Toffler writes, are already suffering from future shock.

Cass Elliot — I've never had my chemistry changed by a movie before as it was by "2001."

Vidal's "Myra Breckinridge," Bantam Books has purchased for \$1500 the 16-foot-high, 500-pound fiberglass statue in Hollywood that was photographed for the book cover and plans to tour it coast-to-coast, then offer it to a New York museum. The statue was used to advertise the Sahara Hotel of Las Vegas. Bantam considered a "Myra Breckinridge" contest, with the winner getting a round-trip to Denmark, but decided



The Blue Meenie

Arthur C. Clarke's "Childhood's End" and Robert Heinlein's "Stranger in a Strange Land" have been optioned for the movies . . .

BOOKS/March, 1968 5

—From "The Wind in the Willows"

"Now that I'm here, where am I?"

—Janis Joplin, West Coast blues-rock star after a stunning debut in New York, where it counts.

"The Poetry of Motion! The REAL way to travel! The ONLY way to travel! Here today — in next week tomorrow! Villages skipped, towns and cities jumped — always somebody else's horizon! O bliss! O poop-poop! O my!"

BOOKS/March, 1968 3

Subject Guide to Books in Print

Subject Guide to Books in Print
Annually in the Fall; 2724 pp. (1967)

\$18.25 postpaid

Subject Guide to Forthcoming Books

\$7.50 for one year (bi-monthly)

111 Avenue
K, N.Y. 10036

We use it; maybe you can. In one fat book are all the titles in print, along with cost and publisher, listed by subject category. Addresses or publishers are given in the front of the book. Outside of a library, there's no better way to find out what's available in a particular area. If you're trying to stay current in your field, the bi-monthly Subject Guide to Forthcoming Books may be preferable.

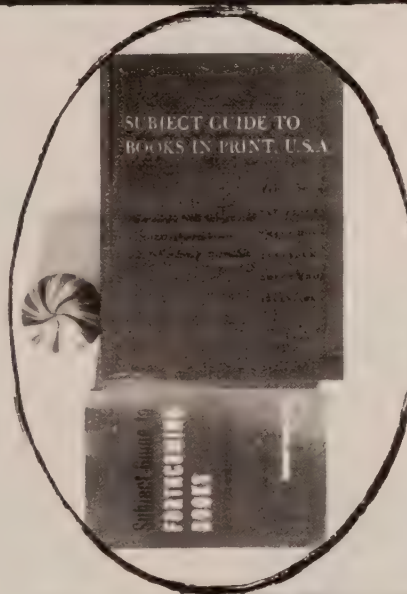

Electronics

Includes Radio & TV Technology

A B C's of Electronic Test Equipment Smith D A rev
1968 295 pp 2.95 Sams
Advanced Techniques for Troubleshooting with the
Oscilloscope Gootman R L Nov 10 1968
7.95 pap 4.95 GL TAB Bks
Advanced & Extra Class Amateur License Handbook
Fyle H S 2nd ed Aug 1968 pap 3.50 Sams
Alan Hissman & the "Time of Time" Ward J Aug 3
1968 4 1/2" pap Doubleday
Anglo American Microelectronics Equipment Data
1968 1969 2 Vols Ed by Dummer G W &
Robertson J M Aug 1968 46 00 na 90 00 set
Pergamon
Antennas in Inhomogeneous Media Gates J Aug
1968 12 00 Pergamon
Art & Science of Photography Newhall B et al date not
set pap 2.95 Century Hve
Broadcast Station Operating Guide Robinson S Sep
20 1968 9.95 pap TAB Bk
Choice of Weapons Parks G (YA) Nov 1968 pap
0.75 Noble
Classical Network Theory Belevitch V Sep 1968
15.75 Holden Day
Closest Circuit TV for Engineers & Technicians
Shogalter L C Oct 1968 8 00 Sams
Lotor TV Servicing Buchalaum 2nd ed Jul 10 1968
9.95 PH
Communications with Electricity-Electronics Culpepper
M A (Eli) Nov 22 1968 price not set McKnight
Computer Programming Principles, Vol 2 Fortran
Wimmert R J Sep 1 1968 pap 4.95 HR&W
Computer Programming Principles, Vol 2 Machine
Assembly Language Wimmert R J Sep 1 1968
pap 4.95 HR&W
Data Acquisition & Processing in Biology & Medicine
Vol 5 Ed by Enslin K Aug 1968 16 00
Pergamon

Electrical & Electronic Signs & Symbols Midleton R
G Jul 1968 pap 4.50 Sams
Electrical Installations Technology Whitfield J Jul
1968 7 00 pap 5.50 Pergamon
Electronic Cable Handbook Belden Manufacturing
Company Engineering Staff 2nd ed 1 inc 1968 pap
4.50 Sams
Electronic Devices & Circuits, Vol 1 Pridham G J Aug
1968 7 00 pap 5.00 Pergamon
Electronics for the Beginner Stanley J A 2nd ed Sep
1968 pap 3.95 Sams
Electronics Handbook for the Electrician Sands L G
Oct 1968 5.95 Chilton
Equidensitometry Lau E & Krug W Nov 1968 18 00
Focal
Expansion Joints in Bridges & Roads Koster W Nov
1968 29 50 Transatlantic
Exposure Record Adams A Jul 15 1968 lea spiral
bdg 4.95 Morgan
Faces of Japan A Photographic Study Lensen G A
Nov 1968 30 00 Diplomatic
Faces of Japan A Photographic Study Lensen G A 1st
ed Nov 1968 27 50 Diplomatic
Faults in Photography Causes & Correctives Fritsche
K Sep 1968 12 50 Hastings
Film Makers Guide Branston B Jul 1968 6 75
Hilary
Five Girls Haskins S Oct 1 1968 pap 1.45 Bantam
From Electrons to Power AC DC Woolman M &
Valentine C G Jul 1968 text ed 9 20 Glencoe
Fun with Lupa Stash J G Aug 1968 5.95 A S
Barnes
Golden Web A History of Broadcasting in the United
States Volume 2 1933-1953 Barnouw E Oct 31
1968 9 00 Dutton U P
Gordon Parks A Post & His Camera Parks G Intro by
P Kunhardt Jr Pref by S Spenner Nov 21 1968
8 95 Studio Viking Pr
Ham Radio Incentive Licensing Guide Simon B Sep
1 1968 6 95 pap 3 95 TAB Bks
Handbook of Modern Halftone Photography Noemer E
F rev ed Aug 1968 11 80 Pagra Supply
Handbook of Vacuum Physics Pts 4 & 6 Ed by Beck A
H Aug 1968 6 00 Pergamon

Art Prints

Since 1949 UNESCO has been trying to update and internationalize the world of Art Prints. They have a central archives of prints, and a committee of experts who decide which prints to include in their catalogs. The criteria are: quality of print, significance of the painter, and importance of the painting.

There are two UNESCO print catalogs: Catalogue of Colour Reproductions of Paintings Prior to 1860 and the same of paintings 1860 to 1965. Both are understandably limited in scope by what quality prints are available. Paintings 1860 to 1965, the only one on hand to review, is further limited by the imbalanced outdated European standard used to select the 1590 prints presented. 225 painters are represented, allowing approximately 7 prints per painter. Yet there are 92 Picassos, 72 Renoirs, 61 Klees, 25 Manets, 50 Monets, 18 Kokoshkas(?) 18 Legers(?) and 36 Dufys(!) etc. Hence: 1 Dali, 1 Duchamp, 1 Ernst, 1 Wyeth, 0 De Chiricos. Further: questionable selection among 5 Magritte and 6 Munch. Not represented are contemporary Americans Albers through Zavorskas.



GAUGUIN

430 LA FEMME DU ROI (LA FEMME AUX MANGIERS) / THE KING'S WIFE / LA ESPOSA DEL REY. 1896

Huile sur toile, 97x130 cm - Oil on 38 1/4 x 51 1/4 in.
Gosudarstvennyj muzej izobrazitel'nyh imeni A. S. Puškina, Moskva

Reproduction: Offset, 21,3x28 cm - O 8 1/4 x 11 in.
Unesco Archives: G.268-69
Editions Est-Ouest
Editions Est-Ouest, Bruxelles, 50 FB

Out of place are three Australian aboriginal paintings.

Much is missing from this catalog yet it can still be useful. It lists only quality prints. Each entry includes the painter's name, place and dates of his birth and death, a black & white photo of the painting, its name, date, medium, size and the collection in which it rests. The printing process, printer (when possible) and publisher are given for each reproduction as well as the UNESCO archives number, dimensions and price (in currency of country where published when possible). Also there are lists of publishers and printers and information on purchasing prints.

Catalogs are trilingual in French/English/Spanish and all dimensions are given in both inches and centimeters.

If you want good prints for the classroom or other irritating empty space — try these catalogs. [Reviewed by Joe Bonner]

Catalogue of Color Reproductions of Paintings Prior to 1860

Catalogue of Color Reproductions of Paintings 1860-1965

1966; 561 pp.
\$7.00 each, postpaid

111 Avenue
K, N.Y. 10036

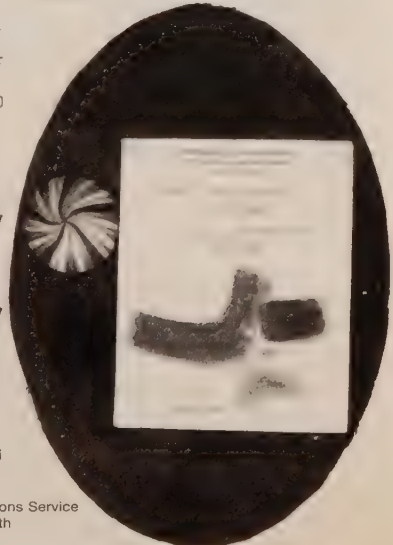

The Modern Utopian

Intentional communities by now constitute a realm of activity worth having a magazine. This is the magazine, and it is very good. Dick Fairfield, who edits *Modern Utopian*, clearly has knowledge of the traditions behind intentional communities as well as notions about their possible futures. His information network is broad, so reports of current communities are wide as well as deep. As we're going to press, *Modern Utopian* is organizing an information service for individuals wanting to find a community to suit them and vice versa.

Starting a community farm is an incredibly difficult thing. We didn't fully realize this when we began. Setting up a new farm -- or rather, rehabilitating an old and neglected one -- was at least a season's work. Not to mention compensating for the work which should have been done the previous autumn.

SOUTH AMERICA TAKE IT AWAY

In the Chaco of Paraguay, fertile land is almost free, taxes are low, government interference is small. Some groups operating communities there, such as the pacifist Bruderhof, are granted a 10-year exemption from certain import tariffs, and permanent exemption from conscription by the military. Immigrant Group Settlements in Paraguay is a good book by a professor at Bethel College, a Mennonite school in Kansas.

The cool Brazilian highlands have less fertility than the Chaco, but the climate is better, as are the political and cultural environment. Land 300 miles north of the new capitol, Brasilia, sells for \$2 an acre, taxes are low, tariff exemptions are granted, and U.S. citizens have the same rights as Brazilians. Fall-out is less in the Southern Hemisphere. For free brochure on Brazil land, write Selig Bros. Real Estate Co., P.O. Box 26034, Indianapolis, Ind. 46224.

--Gerald Baker.

Whether it is guarding a shrine, making electric music, applying Gestalt Therapy or feeding transient hippies, all viable communities have a conscious intent and meaningful function. As opposed to the lack of meaningful direction in today's American society, a conscious sense of purpose is the actualizing force if the community is to be more than a particularization of the social malaise it seeks to answer. Functions may change, sometimes with a rapidity which causes misunderstanding within the community; these changes, how they occur, and the control of change must be understood throughout the community.

The Realist

Green Revolution

If *The Realist* is the father of recent underground newspapers, *Green Revolution* is the mother of community newsletters. Both are kind.

The Realist
Paul Krassner, ed.

Green Revolution
Mildred Loomis, ed.

\$3.00 for 10 issues

\$3.00 for one year (monthly)

from The
59
New

from
Sch
He
Fre

Books On Community in the Heathcote School of Living Library

Island, by A. Huxley, Bantam, 95¢.

Walden Two, by B. F. Skinner, Macmillan, \$1.95.

Animal Farm, by George Orwell, Signet, 75¢.

California Utopian Colonies, by R. V. Hinds, Yale Univ. Press, \$1.45.

American Communities, by R. V. Hinds, Corinth, \$1.45.

Communitas, by Paul Goodman, Vintage, \$1.25.

Patterns of Anarchy, by Krimmerman-Perry, Doubleday, \$1.95.

Stranger in a Strange Land, by R. A. Heinlein, Berkley, 95¢.

Utopia, by Sir T. More, Washington Square Press, 45¢.

Harrod Experiment, by Robert Rimmer, Bantam, 95¢.

Compulsory Miseducation and Community of Scholars, by Paul Goodman, Vintage, \$1.95.

Go Ahead and Live!, by M. J. Loomis, Philosophical Library (order from School of Living), \$4.00.

Kibbutz, Venture in Utopia, by M. E. Spiro, Schocken, \$1.95.

Young Church in Action, by J. B. Phillips, Macmillan, 95¢.

To the Finland Station, by Edmund Wilson, Doubleday, \$1.95.

Brook Farm, by L. Swift, Corinth, \$1.95.

Brave New World, by A. Huxley, Bantam, 75¢.

Brave New World Revisited, by A. Huxley, Perennial, 50¢.

Republic, by Plato, Modern Library, \$1.95.

Looking Backward, by E. Bellamy, Signet, 75¢.

1984, by George Orwell, Signet, 75¢.

Anthem, by Ayn Rand, Signet, 60¢.

The Green Revolution



The Modern Utopian / A Way Out
Dick Fairfield, ed.

\$4.00 for one year (bi-monthly)

from: The Modern Utopian
240 Monte Avenue
Berkeley, California 94709

Dear Friends,
I have spent over twenty years in what is now called the "Hippie Movement", living in short-lived communes based on an anarchistic freedom and long-lived communes based on religion, taking part in political activities such as CORE work in the early 50's and the political action era of the Sexual Freedom League, and writing for, drawing for and editing little literary reviews and underground newspapers. This experience has brought me, gradually and reluctantly, to certain conclusions that I'm pretty sure some of your readers will dispute, yet to me they seem inescapable.
First, those communities based on freedom inevitably fail, usually within a year.
Second, those communities based on authority, particularly religious authority, often endure and survive even against vigorous opposition from the outside world. (The best example of the strength of religious authoritarianism is the monasteries and nunneries of the Catholic Church.)
How, then, can an intentional community possibly be superior to conventional society? If the intentional community hopes to survive, it must be authoritarian, and if it is authoritarian, it offers no more freedom than conventional society. I am not pleased with this conclusion, but it now seems to me that the only way to be free is to be alone.
ORO, El Cerito, Calif.

BEAUTIFUL NATURAL GRAIN CEREAL - PUT ALL THE GRAINS IN A LARGE CAN - MILK - THIS CAN WILL LAST 4 PEOPLE 2 MONTHS - EAT IT EVERY DAY AND STRENGTH WILL COME TO YOU - WASH MILK AND HONEY OVER IT - MILK AND SUGAR - COOK IT LIKE OATMEAL - FOR CAMPING ADD WATER

6 lbs of OATS	2 oz SOY LECITHEN
6 lbs WHEAT FLAKES	3 oz GROUND CHIA SEEDS (USE BLEACHED TO GRIND)
6 lbs RYE FLAKES	2 lbs NUTS
3 lbs WHEAT GERM	1 lb SOY FLOUR (OR CORN FLOUR)
3 lbs SUNFLOWER SEEDS	3 lbs SESAME SEEDS
1 1/2 lbs PUMPKIN SEEDS	
4-6 lbs RAISINS	ORGANIC FAMILIA
3-5 lbs DRIED FRUIT	
3 oz RICE POLISHINGS	

ADD ANY SOFT CHEWABLE GRAINS YOU LIKE - KEEP ADDING TO IT - ALWAYS CHANGING

eat and enjoy

"Dinner begins with a song followed by a short meditative silence. Sometimes a record is played, or the news listened to. During dinner we report on the day's happenings at our jobs, things we've read, and discuss the news. Around dessert we share the day's mail. Then dishes and lunch-packing. Usually Connie and Rae--either separately or together--prepare dinner. The men usually either wash or rinse dishes. Connie packs lunches one week, Rae the next.

Planning, and even engineering, are therefore vital to the community. Skinner put an architect into the original planning group of his Walden II. Even if behavioral engineering is not to be a community concern, design must be considered, for defense against the state if for no other reason. But the real benefits are deeper. The established architecture of today, as exemplified by the code, has failed, and no longer creates viable environments for man. The new communities must design for a new life for man, and only through them can a new architecture of living and expanding be achieved.

All Watched over by Machines of Loving Grace

I like to think (and the sooner the better!) of a cybernetic meadow where mammals and computers live together in mutually programming harmony like pure water touching clear sky.

I like to think (right now, please!) of a cybernetic forest filled with pines and electronics where deer stroll peacefully past computers as if they were flowers with spinning blossoms.

I like to think (it has to be!) of a cybernetic ecology where we are free of our labors and joined back to nature, returned to our mammal brothers and sisters, and all watched over by machines of loving grace. The Realist



The Realist

Community 41

IV. America a nation so incredibly wealthy in 1968 that all morality is based on EXCESS: true American career counselors now ask only one question.

"Do you want to produce garbage or do you want to collect garbage?"

Industrialist or politician?
Fishfarm or junkyard?
The young people want no part of it, of course, what with garbage their natural matrix & medium.

Produce it?
Collect it?

They want to fuck in it!
The career counselors build marvelous constructions of seduction & mystery, they trans-substantiate symbol money

into sex
into power
into death insurance
into pleasure.

But it's just THINGS, it's garbage, it's overflow & the young people know it.

They throw the career counselor out the window.
Who's going to collect the garbage?

who knows?
who cares?

Let's use it to act out our fantasies, use it for unimaginable gratifications.

The Realist



Kibbutz: Venture in Utopia

This book is a straight forward description on one Kibbutz. It is the history, the problems, and the moral codes of a community which began in 1920 and has grown steadily since that time. Over a span of several generations it has grappled with problems, both economic and social, which are similar to problems faced by the community movement in the United States today.

The book examines critically and sympathetically the issues of property, marriage, education, comfort, and communication as it has been dealt with over the various period of this Kibbutz.

While the book is of limited practical value as a how-to-do-it text, it offers a long term perspective on the difficulties and advantages of the community way of life.

[Reviewed by James Fadiman]

This is a community which was founded, for the most part, by middle-class intellectuals who deliberately chose to be workers. . . . Instead of aspiring to "rise" in the social ladder, they aspired to "descend". . . . This Tolstoyan attitude toward work could be evolved, it is not hazardous to say, only by romantic, urban intellectuals.

...the moral postulates of Kiryat Yedidim. . . are important not only because they constitute the basis for the social structure of the Kibbutz, but because they provide a clue to an important premise of its living: the premise that life is serious. It is serious because the realization of these values, rather than immediate pleasure or self-seeking, is taken to be the purpose of living.

The notions of the movement were simple. They included a revolt against tradition; a love of nature; a love of nation, which seemed to consist of a vague mystique of the "folk"; self-expression; emphasis on the emotional aspect of life; the gospel of "joy in work."

But this emphasis on youth and on the equality that exists between the young and the old create a potentiality for a condition of inequality - an inequality in which the young assume the superior, and the old the inferior, status.



Kibbutz: Venture in Utopia
Melford E. Spiro
1956, 1963; 266 pp.

\$2.25 postpaid

from
Anchor Books, Inc.
675 Avenue
New York, N.Y. 10016
or
WHOLE EARTH CATALOG

His job becomes more than a job and more than a way of making a living. It becomes a sacred task, a calling, in the religious sense of the term, dedicated, not to the greater glory of God but to the welfare of the group.

Instead of cooking and sewing and baking and cleaning and laundering and caring for children, the woman in Kiryat Yedidim cooks OR sews OR launders OR takes care of children for eight hours a day. She has become a specialist in one aspect of housekeeping. But this new housekeeping is more boring and less rewarding than the traditional type.

The kibbutz, it will be remembered, was originally conceived as a means to an end - the creation of the new man. Instead of the selfish, aggressive personality created by urban capitalism, there would emerge, as a result of the new social order, a kindly, altruistic personality. This end has not been achieved.

Dune

A more recent Hugo Award winner than *Stranger in a Strange Land*, *Dune* is rich re-readable fantasy with clear portrayal of the fierce environment it takes to cohere a community. It's been enjoying currency in Berkeley and saltier communities such as Libre. The metaphor is ecology. The theme revolution.

Too late, Jessica saw what was happening: the old woman was dying and, in dying, pouring her experiences into Jessica's awareness as water is poured into a cup. The other mote faded back into pre-birth awareness as Jessica watched it. And, dying-in-conception, the old Reverend Mother left her life in Jessica's memory with one last sighing blur of words.



Dune
Frank Herbert
1965; 544 pp.

\$.95 postpaid

from
Anchor Books, Inc.
675 Avenue of the Americas
New York, N.Y. 10036
or
WHOLE EARTH CATALOG

Groups Under Stress

This is a physiological study of the behavior of the three 10-man diver teams who spent 14 days 250 feet down in the Pacific in SEALAB II. The teams lived and worked in a 12'x57' cylinder under high hazard and high public visibility conditions. Their performances were exemplary, and this book seeks to 1) Explain the high performance level and 2) Improve methodology for such psychological studies in the field.

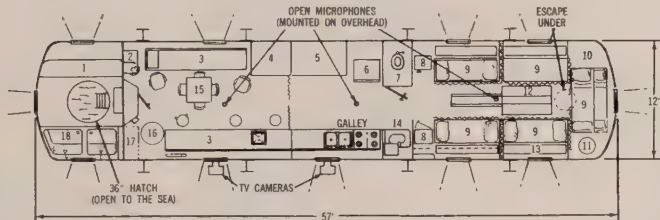

SEALAB II. Interior arrangement; Top removed-looking down. 1. Swim gear stow. 2. TV. 3. Lab bench. 4. Fan room. 5. Electric power and light. 6. Reefer. 7. Head. 8. Locker. 9. 2 Berths. 10. Stow. 11. CO₂ can. 12. Table. 13. Bench. 14. Lav. 15. Table and chairs. 16. Water heater. 17. Can stow/g. 18. Tub and shower.

Subjects under high fear found the task significantly more enjoyable than those in a low fear state. It was reasoned that individuals resolved their dissonance about being in the threatening situation by concluding that it was really a rewarding and enjoyable experience.

The pattern of correlations is highly consistent and indicates that men from smaller towns reacted more favorably to the stressful conditions present.

On one occasion, a diver, in his squeaky Donald Duck voice, said "I have a message for the earth people. Fuck you!"

42 Community

The book is technical, but it may be useful to groups who wish to improve their performances on one frontier or another, or to leaders who are interested in highly motivated teamwork, or to anyone wishing to analyse group doings.

COSTS AND REWARDS IN EXOTIC ENVIRONMENTS

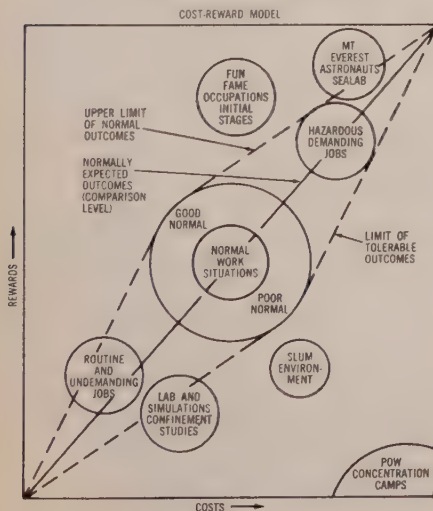

The question is why men are attracted to dangerous and demanding situations and why they make successful adjustments and perform well in highly stressful situations; correspondingly, why they reject, make poor adjustments and perform poorly in less stressful situations.

Then suddenly I realized that we made it. It was a real sense of well being, by golly, something like the Northwest Passage on a very tiny scale. We made it and even though it was only 250 feet from the habitat it was a real accomplishment. It was very pretty. It wasn't pretty as far as the scenic value, but it was beautiful in that it was what we were fighting to get to. The canyon rim.

People were nice to me than they were on the surface. And I was nicer to them than I am on the surface. This SEALAB bunch, we have a hell of a high esprit de corps. We all respect each other. And this is something. Even though you hate a guy's guts, you respect him.

I personally was amazed at how well we did get along under such cramped conditions. It seemed to me everybody just went out of their way to be nice. You were bumping into people and knocking their stuff over and they were bumping into you and knocking your stuff over. It seems to me that everybody was just overly polite about it because they realized this condition existed and if dissension ever once did get started it would spread like wildfire.

Q. You censored your emotions?

A. I censored my emotions. I don't know about the rest of the fellows. I sure did.

Firstborns reported significantly higher fear and lower well being while logging less diving time and making fewer sorties from SEALAB.

The significance of group support is well summarized in the sentiment expressed by a member of an Antarctic wintering over party who said: "If the rest of the guys get fed up and stop talking to you. . . that is worse than when they go off and leave you in a cravasse" (Rohrer, 1960)

Groups Under Stress-Psychological Research in SEALAB II

Roland Radloff, Robert Helmreich
1968; 259 pp.

\$5.00 postpaid from

Anchor-Century-Crofts
400 Avenue South
New York, N.Y. 10016
or
WHOLE EARTH CATALOG

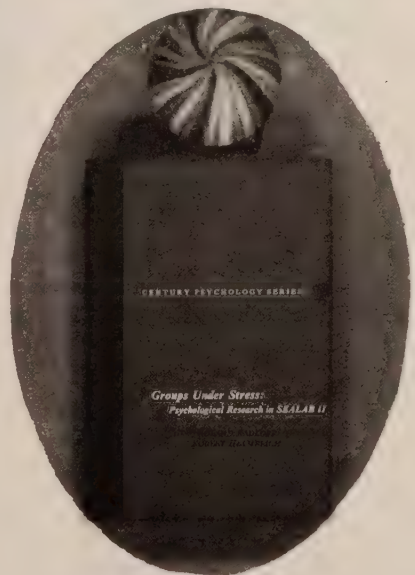

The Merck Manual

In 1850 type-packed pages this book covers most of the possible illness and injuries that can occur to human beings. Each difficulty is described, symptoms are discussed and suggested treatments are indicated.

The writing is extremely technical and is designed as a ready reference for practicing nurses and physicians. Unless you are at ease with the unusually colorful language of modern medicine you will need a medical dictionary to fully understand this book.

While a considerable portion of the advice given is sensible and does not require a doctor's presence, much of the book will not be of use to persons who do not have access to medical supplies. This book is not intended in any sense for primitive or simple living conditions; it does not describe alternatives if medical treatment is not available nor does it suggest folk treatments in lieu of hospitalization. However, if you want to understand what is going on when a member of your family or community is seriously ill, this volume can be helpful. There is an excellent index as well as a special section devoted to specific prescriptions and special therapies. The excerpts given below illustrate both the common-sense and the technical aspects of this volume.

[Reviewed by James Fadiman]

DISTURBANCES IN ELECTROLYTE (Mineral) METABOLISM
Dilutional hyponatremia will occur when excessive water is given to a patient in whom antidiuretic hormone activity (postoperatively, or in bronchogenic carcinoma, head injuries, or porphyria) or a low glomerular filtration rate is present. Movement of the water from cells in E.C.F. with glucose concentration may produce a temporary hyponatremia.



The Merck Manual
11th edition 1966; 1850 pp.

\$7.50 postpaid

from: Merck and Co., Inc.
Rahway, New Jersey 07065

PITUITARY-ADRENAL

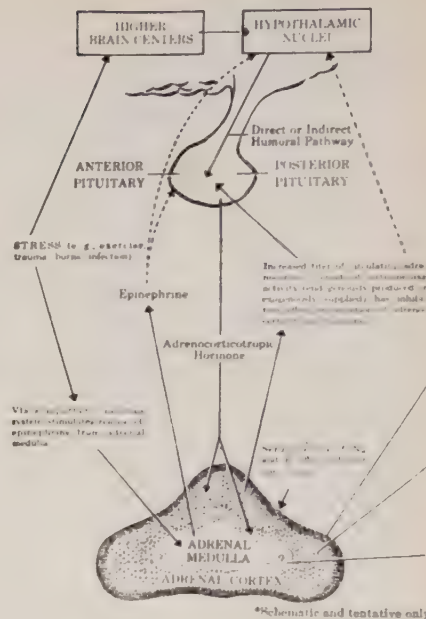

HEAT HYPERPYREXIA (sunstroke, heatstroke, thermic fever, siriasis)
Etiology: prolonged exposure to excessively high temperature or the direct rays of the hot sun, combined with exercise and lack of air circulation are the responsible factors.
Symptoms and Signs: Onset may be sudden or may follow complaints of weakness, headache, vertigo, anorexia, nausea and precordial distress. The temperature rises rapidly to 105 or 106 F. or higher. Convulsions and projectile vomiting may develop and are of serious import.
Treatment: heroic measures are indicated and must be instituted immediately. If the rectal temperature is 106 F. or over, an ice water tub bath or a blanket soaked in water is indicated, and the skin should be rubbed vigorously until the temperature falls.

[Innovator reports that many prescription drugs can be obtained without a prescription and at low cost from veterinary supply houses. - SB]

DYSPEPSIA ("indigestion")

Treatment
General: The patient should eat a balanced diet (see DIETS, Normal Diet). At least 1 hr/meal should be allowed. Food should be chewed thoroughly without haste and not constantly 'swilled down' with liquids. When possible meals should be taken in a pleasant, quiet, relaxing environment. Smoking immediately before meals should be prohibited. Food should be properly cooked, appetizing and eaten in moderate amounts. Following a meal, the patient should avoid excitement.

Land for Sale

If land's your fantasy, these two realty catalogs will give you the best idea of what are the prices you can expect in various regions of the U.S. and what sort of parcels are available. If you're set on one particular region, of course, you're probably better off shopping the local word-of-mouth market.

United Farm Agency Catalog Strout Catalog

Free

from: United Farm Agency
Cincinnati, Ohio
47th St.
City, Missouri 64112
and other local offices

Free

from: Strout Realty
San Diego, California
Green Street
San Diego, California 91101
and other local offices.



WATER-FRONT INNI
No. 966—1 acre. \$23,000. Completely furnished and equipped 3-story Colonial inn offers outstanding potential for ski lodge, guest hotel or private school. 1 level acre with



200-ft. frontage on picturesque lake with sandy beach. In small resort town. 1 1/2 miles to new interstate highway, within 3 miles of college, near 3 ski areas, 2-hour drive to Boston. Inn is in good repair, 21 rooms, 15 bedrooms, 6 baths, aluminum combination windows, basement, NEW baseboard hot-water



heating system with 3 zones, NEW artesian well. Once-in-a-lifetime opportunity at only \$23,000. UNITED, Bradford, N. H.

United Farm Agency

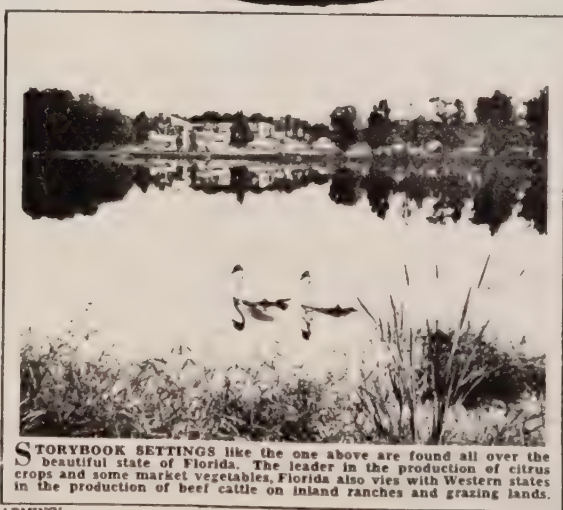

STORYBOOK SETTINGS like the one above are found all over the beautiful state of Florida. The leader in the production of citrus crops and some market vegetables, Florida also vies with Western states in the production of beef cattle on inland ranches and grazing lands.

United Farm Agency

FOR SUCCESSFUL FARMING!



No. 374 - 100 ACRES - \$27,500. 68 acres of high-yielding cropland. 2 springs, well for water. Spacious 8-room home; full basement, bath, furnace. 30x88 barn w/20 steel stanchions, barn cleaner, milk house, 275-gallon bulk cooler; double corncrib, granary, hog house, 2 silos, nearly new 40x80 metal machine shed, tile workshop. Excellent buy at \$27,500. STROUT, Reedsburg, Wis.

Strout

CROPS SAY "TOPS!"
No. 311 - 234 ACRES - \$50,000. Reputation for excellent corn, oats, hay production! Heavy loam soil - 130 acres tillable, 50 wooded. Well, spring, creek for water. Well-maintained 7-room & bath 4-bedroom home w/part basement. 34x86 drive-thru barn w/40 stanchions; 36x70 machine shed, 2 large corncribs, hen house. On school bus route, short drive to Reedsburg. Includes 45 head dairy cattle, 3 hogs in price of \$50,000. STROUT, Reedsburg, Wis.

BEST FOR BEEF!



Strout

Consumer Reports

If you're buying current models of anything you might as well get Consumer Reports and feel better about your choices. Like: here comes Christmas and Mom says what do you want and I say Mom I want sound and she says What and I say wait a minute and I look at the CR Buying Guide and under record players it says the Acoustic Research XA is the best and also a best buy so I say Mom I want an AR XA it costs 78 bucks is that OK and she says m OK and everybody feels good and it didn't take very long. Thank you Mom. Thank you Consumer Reports

The magazine also carries procedural advice on how not to get stung in the consumer jungle. Plus you get to lobby vicariously against danger and untruth in products.

Now what we need is a Consumer Reports of second-hand stuff.

Consumer Reports

\$6.00 for one year (monthly - December issue is Buying Guide)

from: Consumers Union
Cincinnati, Ohio
Mason, N.Y. 10550



present ownership for 9 years. 40x 80-ft. 2-story brick building, good condition. Hardware inventory included. 40x115-ft. lot. On state highway, 14 miles Syracuse. Disability prompts sale at \$47,000. UNITED, Sennett, N. Y.

United Farm Agency

Government Publications

Relatively expensive access to phenomenally inexpensive information. If you or your group don't have money and do need technique, this may be your best source. Many of the government publications are outstanding. By and by we hope to have reviews of many specific good ones in the CATALOG. One drawback: the government grinds fine but very very slow - shipments take forever.

Inventions Wanted by the Armed Forces and Other Government Agencies: Cumulative Vol. 2 [List]. Natl Inventors Council, 1964. 62 p. Free from the Council.
This hopeful inventory contains enough ideas to keep all of us hoping for some time.

Understanding the Atom Series. Atomic Energy Comm., 1963-67. Free from the Commission.

This extraordinarily handsome and informative group is published by the Division of Technical Information of the AEC. With some exceptions (recognizable by their titles), all of the group are intended to be as nontechnical as anything in this field can be. The entire series deals with every aspect of the subject, except the military; moreover, the series is aimed at several levels of understanding and background. Each of the titles is excellently illustrated. All carry reading lists. Since a great many of the titles have been issued very recently and were received too late by the compiler to permit individual annotation, only this broad introductory note is possible. The titles are recommended for school use and for the general public. The generous policy of the AEC, in making these very fine booklets freely available, deserves mention. Requests should be addressed to:

United States Atomic Energy Commission
P.O. Box 62
Oak Ridge, Tennessee 37830

Complete sets of the group are available free to schools and to public libraries, and to teachers who can make them available for reference or for use by groups.

Bark Canoes and Skin Boats of North America. E.T. Adney and H.I. Chapelle, Natl. Museum, Bull. 230 (1964). 242 p. il. \$3.25

SI 3.3:230

Of great historical interest. Also tells you (with plans) how to make these canoes.

Manual of Septic Tank Practice. Public Health Serv. 1960. 91 p. il. 40c FS 2.6:Se 6/2
A fine detailed guide to proper maintenance and repair.

Controlling Mosquitoes in Your Home and on Your Premises. J.A. Fluno, Agr. Dep., Home and Garden Bull. 84 (1962). 12p. il. 10c A 1.77:84



A Popular Guide to Government Publications

W. Philip Leady
1968; 363 pp. 3000 items

\$12.00 postpaid from
Crown University Press
Sales Department
Irvington-Hudson, N.Y. 10533
or
WHOLE EARTH CATALOG

Home Poultry Flock. Agr. Dept., Leaflet 497 (1965). 8 p. il. 5c A 1.35:497

A simple guide for the small scale producer.

Wood Handbook: Basic Information on Wood as a Material of Construction, with Data for Its Use in Design and Specification. Agr. Dept., Agr. Handbook 72 (1955). 528 pp. il. \$2.25 A 1.76:72

A good deal of the information here will be of interest to anyone working with common woods for building or carpentry.

Recipes [Navy-Marine Corps Recipe Serv.]. Navy Dept., Supplies and Accounts Bur., 1963. 738 cards, 5" x 8". \$8.25 per set. D 212.2R 24/963

Meant, of course, for very large servings indeed

Anthropology as a Career. W.C. Sturtevant. Smithsonian Inst., 1963. 20 p. 20c. Purchase from the Institution.

Family Guide: Emergency Health Care. Civil Defense Off., 1963. 60 p. il. Free from the Office.

The advice here is not intended to substitute for professional medical care; covering a wide range of illnesses and ailments, it tells you what to do in emergencies - everything from a toothache to childbirth.

Farming Terraced Land. P. Jacobson and W. Weiss. Agr. Dept., Leaflet 335 (1961) [1963]. 14 p. il. 15c A 1.35:335
Excellent illustrated guide to techniques involved.

The Armchair Shopper's Guide

This cheerful book is an uncommonly practical compendium of access. Listed here are all of the major and many of the minor mail order shippers in the world. To a large extent the shippers carry items not available locally. Each source is very well described and compared with its competitors. The Armchair Shopper's Guide is more general than us, and geared to wealthier readers, but if you use the WHOLE EARTH CATALOG very much, you can almost certainly use the Shopper's Guide.



The Armchair Shopper's Guide

Delphine C. Lyons
1968; 218 pp.

\$1.50 postpaid from
Essaness Special Editions
Simon and Schuster, Inc.
63 Avenue
New York, N.Y. 10020
or
WHOLE EARTH CATALOG

Culpeper House, Ltd., 21 Bruton St., Berkeley Square, London W.1, England (catalog free): This distinguished firm is owned by the British Society of Herbalists, so its standards of purity and quality are high.

Here you will find one of the largest available collections of herbs and herbal preparations for all purposes, including many types and blends not easily available here, at prices generally well below American levels. Medicinal preparations include all kinds of herb teas and blends at about 40c to 50c per 2-ounce pack; tonics and remedies, pills and ointments (slippery elm and marshmallow cream is around 60c; corn and wart paint costs 60c). Among culinary products are flavorings, herbs and spices (including combinations and blends of their own), most costing about 50c per ounce, with a few exceptions such as cardamons and mace blades, which hit a top of around \$1.20 per ounce). Oils, vinegars, and such esoteric items as carrageen moss and tree bark are also available.

In addition, there's a line of herbal and floral perfumes and toiletries, with such delightful names as Blue Champak, Sussex Violets, Syringa, or Sweet Beans (which suggest, they say, "a beanfield after a shower of rain") - plus potpourris and pomanders and, if you're brave, herb cigarettes at around 40c for a packet of twenty.

Stechert-Hafner, Inc., 31 East 19th Street., New York, N.Y. 10003 (catalog free): Featured here are scientific, mathematical, and medical books, many of which are also published under the aegis of this distinguished house.

Then a really splendid source, **The Guitar Maker,** 8665 West 13th Ave., Denver, Colo. 80215 (brochure free) has do-it-yourself guitar, sitar, dulcimer, Irish harp, and balalaika kits, beginning as low as \$8 for the dulcimer, and \$9 for the balalaika. For faint hearts, they'll sell the finished instrument at from around two and a half to three times the price of the kit.

W. Atlee Burpee Co., 18th & Hunting Park Ave., Philadelphia, Pa 19132 (catalog free): Probably the best known of all American seed houses, Burpee was founded in 1876, at a time when America imported almost all its seeds from Europe. Mr. Burpee - and, later, his famous cousin Luther Burbank - started a tradition of creating new flowers and vegetables through scientific methods, which the firm continues today under his son's direction. Every year several new varieties of plants are offered.

The familiar catalog with its handsome full-page color illustrations offers a comprehensive listing of seeds - about one-third are vegetables and the rest are flowers - plus garden supplies. A special feature is a page listing types of flowers most appropriate for various purposes, including "easy-to-grow" types for the amateur or unlucky gardener.

Every gardener, from the strictly amateur to the case-hardened professional, knows about Hyponex all-purpose plant food. However, some people don't know that the same firm, **Hydroponic Chemical Co.,** Copley, Ohio 44321 (brochure free) manufactures nine other plant food formulas, as well as special foods for particular plants. Don't let the firm's name fool you. Although their plant foods are, of course, useful in soilless gardening, they're meant for all kinds of plant culture, indoors and out. In addition, Hydroponic offers a famous line of garden and houseplant supplies, many of which are difficult to find locally. It's the only place I know of where you can get sand in small quantities - quarts are less than a dollar postpaid.

↑ Merchandise shipped postage free.

How to Get 20% to 90% Off on Everything You Buy

Well, yeah. Except the book smells of self-improvement. Somehow if you beat your neighbor for bargains it makes you a better person and this a better world. Sure.

There's nothing unique in this book, but all the corner-cutting techniques are here. The main advice is: trade your services or talents or whatever for what would otherwise cost you money. Most of the information won't be new to you, but the ideas that are will more than save you the price of the book - if you take the trouble, which all bargain-finding comes down to.

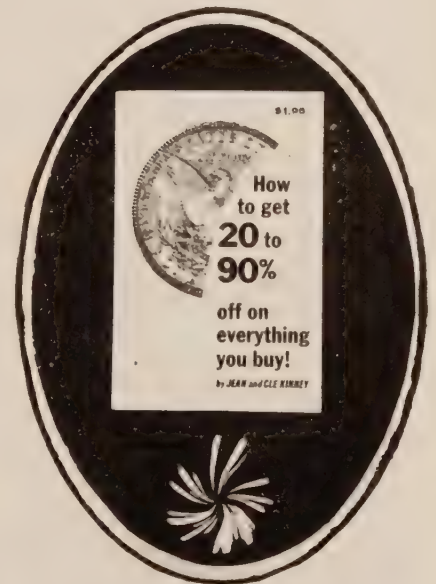

Here are five don'ts to keep in mind when bargaining:

1. Don't try to bargain at a chain store. The store has its prices set at the central office.
2. Don't try to bargain with a clerk in a privately owned store. Only the owner or a strong head of a department is a decision maker.
3. Don't try to cut the price of merchandise that has a set price in all stores. These "fair trade" items have prices set at the manufacturer's home office. Store owners who fiddle with these prices can lose their franchise.
4. Don't pretend to be an expert when buying from someone who knows more about the merchandise than you do.
5. Don't knock the merchandise!

How to Get 20% to 90% Off on Everything You Buy

Jean and Cle Kinney
1966; 255 pp.

\$1.95 postpaid from
Kinney Publishing Company, Inc.
Hall, Inc.
Essex Wood Cliffs, N.J. 07631

Innovator

The people who produce and read *Innovator* are very dubious about Society's chances just now. They expect an *Atlas Shrugged* sort of collapse, and they are preparing for it by defining and becoming proficient at a 'libertarian' way of life: philosophic and bodily survival amid order or chaos. Recently, *Innovator* has shifted emphasis toward bodily survival; carrying information on self-protection, nomadic techniques, community techniques, secure communications, and so forth.



Innovator is published quarterly. *Free Trade*, a supplement devoted to ads and correspondence, comes out monthly. [Suggested by Tom Duckworth]

\$1.00 *Innovator* for one year.
\$4.00 *Innovator* and *Free Trade* for one year.

from
 B. M. P. Greenbank
 Los Angeles, California 90034

The Retreater's Bibliography



Listed here are titles, costs, sources, and some capsule reviews of books relevant to living outside a system. Some of the categories overlap with *WHOLE EARTH CATALOG* listings, and we've found that sometimes we have more complete information, sometimes the *Stephens* do.

Retreater's categories include: *Camping and Survival, Finding a Proper Location, Food Supply and Domestic Animals, Building Your Own Home, Medicine, Education and Retreat Library, Recreation, Protection and Hunting, Land Mobility, Water Mobility, Waste Disposal, and General.*

The Retreater's Bibliography
 Don and Barbie Stephens
 1968; 18 pp.

\$9 50

from
 Enterprises, Ltd.
 Jerano Ave.
 Los Angeles, California 90041

The Book of Survival

The Book of Survival is hilarious to read aloud, which is fine, because the admonitions sink in via the laugh, and, next time you're running from an enraged bull, you remember about flinging down your jacket.



The Book of Survival

Anthony Greenbank
 1967; 223pp

\$5.98 postpaid

from:
 Harper and Row
 49 East 33rd Street
 New York, NY 10016
 Whole Earth Catalog

CREATURES FROM OUTER SPACE (STEPPING FROM FLYING SAUCER)

Avoid rapid forceful movement.
 Use no shrill sounds.
 Breathe quietly.
 Avoid giving a direct menacing gaze.



DOGS

Ordinary village dog in other countries is often dangerous. Semi-starved and savage, its bite can be fatal (if dog has rabies). Signs - glazed eyes/foaming mouth/staggering.

Stone them to keep at bay if they attack you.

With other big dogs try the following deterrents, in this order.

- (a) Hit on nose **HARD** and **FAST**.
- (b) Brace forearm in front of you, offering it to dog. When seized jam it to back of jaws and instantly bring over your other arm (palm flexed and facing floor) so bony edge of forearm forces into back of dog's neck as you force the head backwards and over the arm with a quick jerk. Rolling action

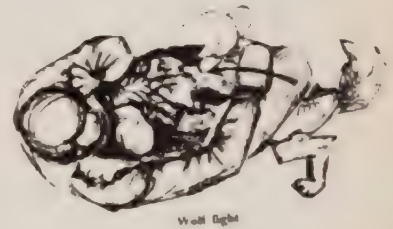

Wall Right



Kidney and head protection

When lying on the ground and being kicked try to keep rolling, shielding parts being kicked with arms. **BUT** Always protect head as priority. Clasp base of skull with both hands, bring wrists across ears and side of head and press elbows together. Bring knees up, crossing ankles to save genitals.

In all attacks it pays to shout/gasp/yell more than you need: Feign pain. Especially when on receiving end (lying on ground and being kicked). Attacker may be satisfied sooner when you appear in agony

PRECOLLISION ACTION WHEN NOT STRAPPED IN

1. DO OPPOSITE OF NATURAL INSTINCT TO PUSH AWAY FROM CRASH
2. FLING YOURSELF TOWARD POINT OF IMPACT...
3. WRAPPING ARMS ROUND HEAD...
4. TWISTING SIDWAYS AND LYING WITH FLANK ACROSS FRONT



Rope climbing using friction knots

FIGHTING DRUNK
 Humor.

If involved in brawl, drunks can offer astoundingly strong grip. Hit his stomach and this may make him sick.

EMERGENCY CHILDBIRTH

Happens anytime. Don't panic. Not unique situation. Let nature handle it with you helping it along

- Above all...
1. DON'T PULL BABY OR ITS CORD OR AFTERBIRTH ATTACHED TO OTHER END OF CORD
 2. TIE CORD AS SOON AS BABY IS DELIVERED.
 3. CUT CORD ONLY IF NO HELP LIKELY. IF HELP ON WAY, TIE CORD BUT LEAVE AFTERBIRTH ATTACHED.
 4. KEEP BABY WARM. PLACE BETWEEN MOTHER'S LEGS

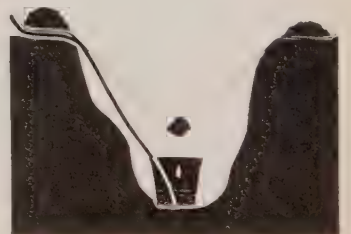

Survival still



The Survival Book

The Survival Book is the best we've seen of the military survival manuals. It was prepared in the late '50s by Allen, Nesbitt and Pond for the Air Force (downed pilots particularly). Mr. Allen tells us that if we customers hassle the publishers, Van Nostrand, they'll come out with a paperback edition.

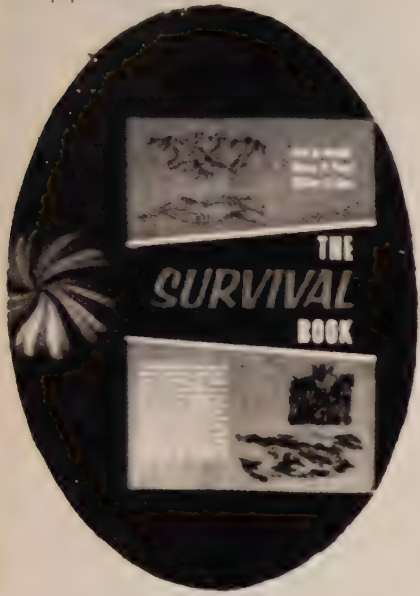

The fruit of all cactus plants is good to eat. Some cactus fruit is red, some yellow when ripe, but all are soft. Any of the flat leaf cactus plants like the prickly pear can be boiled and eaten as greens (like spinach) if you peel or cut off the spines first.

The Survival Book

Paul Nesbitt, Alonzo Pond, William Allen
1959; 338pp

\$8.50 postpaid from: D. Van Nostrand Company, Inc., 120 Alexander Street, Princeton, NJ 08540 or THE EARTH CATALOG

One of the authors once gave a 50-cent Swiss jackknife to a Tuareg noble in the Sahara. Later he received courtesies out of all proportion to the demands of hospitality. Finally the noble explained. "When you first came here you gave me a knife that closes. All my life I have wanted a knife that closes. You are my friend. Anything I have is yours."



Fig. 1. Areas Described in Book

DO'S AND DON'TS FOR THE TRAVELER IN ARABIAN DESERTS

Here are a few of the most important don't's. In general they apply to the deserts everywhere.

- Don't reprimand an offender in front of other people.
- Don't draw sand pictures or maps with your foot - stoop down and draw with your right hand.
- Don't swear at a native.
- Don't expose the soles of your feet to others. Sit tailor fashion or on your heels.
- Don't ask about a man's wife.
- Don't throw a coin at a man's feet. That is insulting.
- Don't try to gamble. It is forbidden.

And here are a couple of Do's worth remembering.

- Do have patience when dealing with desert people.
- Do act friendly.

Deserts are quite healthy places. Dry air is not favorable to bacteria. Wounds usually heal rapidly in the desert, even without treatment. Except in some oases of the Sahara, malaria does not exist in the desert. Venereal diseases, however, are prevalent in both the Gobi and Sahara, and are much more common in Mongolia than in Africa. But unless you lose all sense of proportion as to your immediate situation, you will not become involved in this aspect of desert life.

Give careful thought to the selection of equipment you will carry on the walkout. A 50-pound pack is a heavy load; 20 to 30 pounds is much more reasonable. The four most important equipment items for jungle travel and living off the land are the machete, the compass, the first-aid kit, and the parachute.

The highways of the jungle are the trails and the streams; use them if you have to do any extended travelling. The beds of small streams are usually used as trails by the natives, because it is easier to wade in shallow water than to push through thick undergrowth.

TABLE 1-1

CONDITIONS AT WHICH EXPOSED FLESH FREEZES

Wind Velocity, MPH	Temperature, °F
45	20
26	15
18	10
14	5
13	-0
9	-5
7	-10
6	-15
5	-20
4	-25
3	-30
2	-40

EXPECTED DAYS OF SURVIVAL AT VARIOUS ENVIRONMENTAL TEMPERATURES AND WITH VARYING AMOUNTS OF AVAILABLE WATER

	Max. daily in shade temperature, °F	Available water per man, U.S. quarts					
		0	1	2	4	10	20
NO WALKING	120	2	2	2	2.5	3	4.5
	110	3	3	3.5	4	5	7
	100	5	5.5	6	7	9.5	13.5
	90	7	8	9	10.5	15	23
	80	9	10	11	13	19	29
	70	10	11	12	14	20.5	32
	60	10	11	12	14	21	32
	50	10	11	12	14.5	21	32
WALKING AT NIGHT AND RESTING THEREAFTER	120	1	2	2	2.5	3	
	110	2	2	2.5	3	3.5	
	100	3	3.5	3.5	4.5	5.5	
	90	5	5.5	5.5	6.5	8	
	80	7	7.5	8	9.5	11.5	
	70	7.5	8	9	10.5	13.5	
	60	8	8.5	9	11	14	
	50	8	8.5	9	11	14	

Survival Arts of the Primitive Paiutes

Survival Arts of the Primitive Paiutes is a rare book: it shows in exhaustive well-illustrated detail how one tribe managed its daily survival. I wish someone would do a similar book on Eskimos.

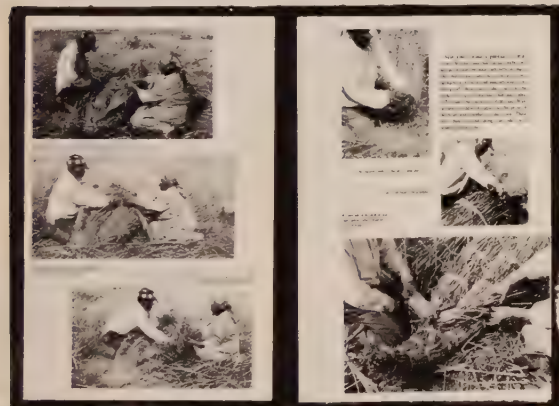

Survival Arts of the Primitive Paiutes

Margaret M Wheat
1967; 177pp

\$10.00 postpaid

from: University of Nevada Press, Reno, Nevada or THE EARTH CATALOG

When the boat was completed, Jimmy stepped in the center to form a deeper hollow. The finished boat was eight-and-a-half feet long but so light that it could easily be lifted with one hand

Shoveling hot coals from the breakfast fire onto the small, brown pinenuts in the winnowing tray, she began immediately to bounce and turn them, keeping them in constant motion to protect the basket from becoming scorched

When the nuts hissed and popped somewhat like popcorn, she knew they were cooked. This first roasting leaves the meat soft and translucent.

To play the game, two people on one side each concealed a pair of sticks or "bones" within their closed fists. One bone of each pair was plain, the other ornamental. The gesser on the opposing team had to choose in which hands the ornamented sticks were hidden. If the guess were correct, his side was awarded a tally stick. If not, his side lost a stick. The side winning all ten tally sticks claimed all the bets. The singers opposing the gesser shouted, waved, and beat the logs to confuse him, but he sat quietly, apparently oblivious to the distractions, concentrating on his choice. It is remarkable how often a good gesser won. Winners were never congratulated, nor were losers ever consoled. The game is still played in the Great Basin with stakes often running into hundreds of dollars

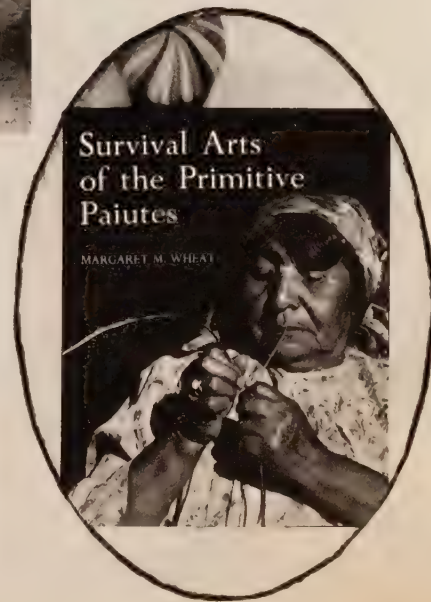
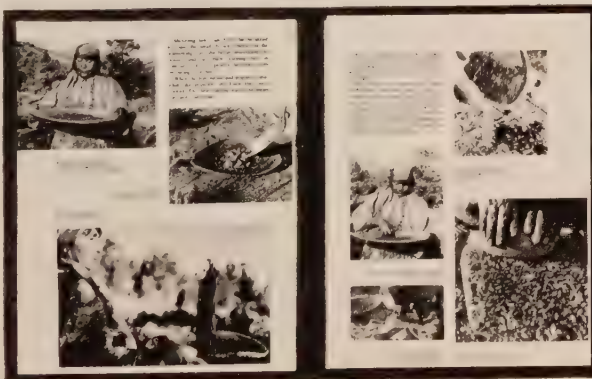

Camping and Woodcraft

When friend Roland goes camping he takes his Bible and his Kephart. I generally leave home the Bible.

How could anything written in 1916 still be so useful? One, it is a masterwork. Two, in Kephart's day when you went camping you really disappeared, so there's a valid nostalgia factor. But the main thing is, the book survives on its wealth of specific practical lore. Game: find the information that is outdated, sort it from the information that is correct and available nowhere else.

Camping and Woodcraft
Horace Kephart
1917, 1921, 1967; 479 pp.
\$6.95 postpaid

from:
The Macmillan Company
86 Avenue
N. Y. 10022
or
WORLD EARTH CATALOG



The charm of nomadic life is its freedom from care, and exposed to the vicissitudes of wilderness life, need a diet rich in protein, fats (especially in cold weather), and sweets. This may not agree with theories of dieticians, but it is the experience of millions of campaigners who know what their work demands. A low-protein diet may be good for men leading soft lives, and for an occasional freak outdoorsman, but try it on an army in the field, or on a crew of lumberjacks, and you will face stark mutiny.

Men working hard in the open, and exposed to the vicissitudes of wilderness life, need a diet rich in protein, fats (especially in cold weather), and sweets. This may not agree with theories of dieticians, but it is the experience of millions of campaigners who know what their work demands. A low-protein diet may be good for men leading soft lives, and for an occasional freak outdoorsman, but try it on an army in the field, or on a crew of lumberjacks, and you will face stark mutiny.

Muddy Water. - I used to clarify Mississippi water by stirring corn-meal in it and letting it settle, or by stirring a lump of alum in it until the mud began to precipitate, and then decanting the clear water. Lacking these, one can take a good handful of grass, tie it roughly in the form of a cone six or eight inches high, invert it, pour water slowly into the grass, and a runnel of comparatively clear water will trickle down through the small end.

Trees and Lightning. - I have never seen nor heard of, a beech tree that had been struck by lightning, although beeches are plentiful on many battle-scarred mountains where stricken trees of other species can be noted by the score.

One glance at a camper's fire tells what kind of a woodsman he is. It is quite impossible to prepare a good meal over a heap of smoking chunks, a fierce blaze, or a great bed of coals that will warp iron and melt everything else.

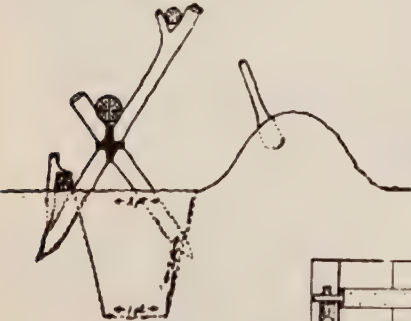

Fig. 113 - Latrine

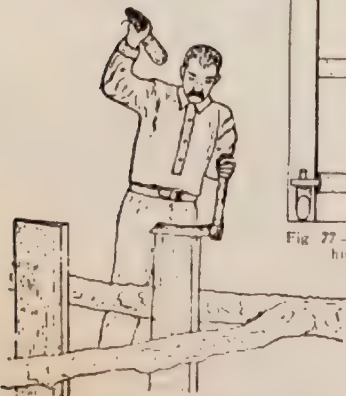

Fig. 77 - Cabin door (wooden hinges and latch)

Fig. 49 - Splitting with a Froe

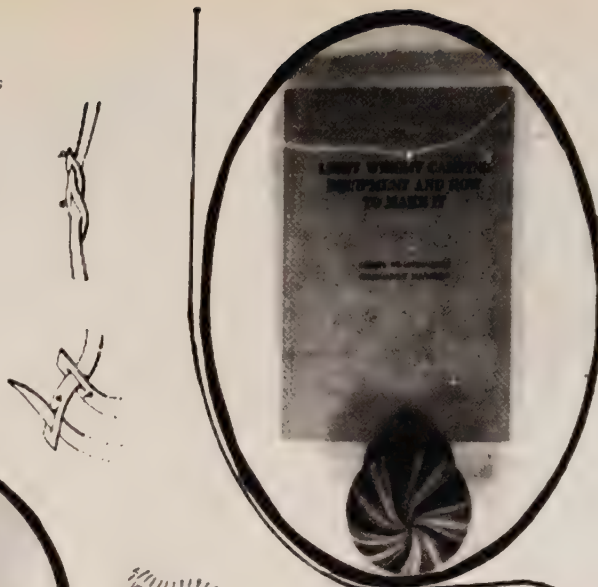

Fig. 68 - A Masked Camp

In Alaska, all animals leave for the snow-line as soon as the mosquito pest appears, but the enemy follows them even to the mountain tops above timber-line. Deer and moose are killed by mosquitoes, which settle upon them in such amazing swarms that the unfortunate beasts succumb from literally having the blood sucked out of their bodies. Bears are driven frantic, are totally blinded, mire in the mud, and starve to death. Animals that survive have their flesh discolored all through, and even their marrow is reduced to the consistency of blood and water. The men who penetrate such regions are not the kind that would allow toil or privation to break their spirit, but they become so unstrung from days and nights of continuous torment inflicted by enemies insignificant in size but infinite in number, that they become savage, desperate, and sometimes even weep in sheer helpless anger.

BENDING WOOD. - Small pieces of green wood can be bent to a required form by merely soaking the



Fig. 54 - Spanish Windlass (for bending wood)

pieces for two or three days in water, but if it is desired that they should retain their new shape, they should be steamed.

Rabbits are unfit to eat in late summer, as their backs are then infested with warbles, which are the larvae of the rabbit bot-fly.

Green Corn - If you happen to camp near a farm in the "Roasting-ear" season, you are in great luck. The quickest way to roast an ear of corn is to cut off the butt of the ear closely, so that the pith of the cob is exposed, ream it out a little, impale the cob lengthwise on the end of a long hardwood stick, and turn over the coals.

Skilligalee - The best thing in a fixed camp is the stock-pot. A large covered pot or enameled pail is reserved for this and nothing else. Into it go all the fag-ends of game - heads, tails, wings, feet, giblets, large bones - also the left-overs of fish, flesh and fowl, of any and all sorts of vegetables, rice, or other cereals, macaroni, stale bread, every thing edible except fat. This pot is always kept hot. Its flavors are forever changing, but ever welcome. It is always ready, day or night, for the hungry varlet who missed connections or who wants a bit between meals. No cook who values his peace of mind will fail to have a skilley simmering at all hours.

A woodsman, on the contrary, walks with a rolling motion, his hips swaying an inch or more to the stepping side, and his pace is correspondingly long. This hop action may be noticed to an exaggerated degree in the stride of a professional pedestrian; but the latter walks with a heel-and-toe step, whereas an Indian's or sailor's step is more nearly flat-footed. In the latter case the center of gravity is covered by the whole foot. The poise is as secure as that of a rope-walker

It is not nearly so much the "make" of rifle as the load it takes that determined the gun's shooting qualities. So, choose first a cartridge, then a gun to handle it.

A more highly prized kinnikinnick is made from the leaves of the bear-berry or uva-ursi (Aretostaphylos-uva-ursi), called sacaommiss by the Canadian traders, who sell it to the northern Indians for more than the price of the best tobacco.

Light Weight Camping Equipment and How to Make

It's all here: design, patterns, assembly techniques, light weight materials, and sources of the materials. Because of good information on what's needed for various environments, it's a useful book even if you aren't making your own stuff. An indispensable book if you are.

[Suggested by Roland Jacopetti]

Light Weight Camping Equipment

Gerry Cunningham
Margaret Hansson
1959; 130 pp.

\$2.50 1 lb. 2 oz shipping weight

5544
Colorado 80217

Parka



Here is a list of sources of supply for the materials. Following the addresses, the suppliers will be listed separately under various materials headings with the specific items they can supply.

- GERRY PO Box 5544, Denver Colorado 80217
- HOLUBAR, 1215 Grandview, Boulder, Colorado-catalog available
- RECREATIONAL EQUIPMENT INC., 523 Pike St., Seattle 1, Wash. catalog available
- THOMAS BLACK & SONS, Scottish Industrial Estate, Port Glasgow, Renfrewshire, Scotland - catalog available.
- TRAILWISE (The Ski Hut), 1615 University Ave., Berkeley 3, California - catalog available.
- SEARS ROEBUCK - local store or mail order catalog
- MONTGOMERY WARD - local store or mail order catalog
- Tent and awning suppliers, yard goods shops, leather wholesalers, luggage shops, marine outfitters, sailmakers, shoe manufacturers and repair shops, harness and saddle shops, mattress and bedding manufacturers, army surplus stores, hardware stores, dry goods departments, handicraft shops, notions departments

Backpacking

A well-regarded inexpensive book on backpacking, kept kept fairly up to date.

[Suggested by Roland Jacopetti]



Backpacking
R.C. Rethmel
1964; 120pp.

\$2.15 postpaid

from:
Th... gordo
Alk... any
io... texico

The Bean catalog is the model for the **WHOLE EARTH CATALOG**. Mr. Bean had a directness and integrity that shows through his catalog, his products, his service. The catalog has excellent items, especially outdoor clothing. An uncommonly pleasant company to do business with.

Catalog: **Free**

from L.L. Bean, Inc.
 Free, 1,
 1952

Bean's Maine Hunting Shoe

Mr. Bean first developed this boot in 1912. He was tired of coming home with wet and sore feet from wearing the heavy leather woodsman boots then in common use. Rubber boots were clammy feeling and too clumsy for all day walking. He decided to combine lightweight leather tops with all rubber bottoms, incorporating the best features of both types of footwear and doing away with the disadvantages. He called his new boot the Maine Hunting Shoe.

The practical advantages of this design were readily apparent to hunters and woodsmen. For bare ground walking it was light in weight, snug fitting, had a cushioned innersole and a non-slip chain tread outersole. For wet going and walking on snow, the waterproof bottoms were ideal. Mr. Bean invented the split backstay to eliminate chafing and by keeping all parts as light and flexible as possible he had a boot that could be used all day in perfect comfort. The Maine Hunting Shoe was an immediate success.



	6 in.	8 in.	10 in.	12 in.	14 in.	16 in.	
Elk-tanned:	\$16.00	\$17.00	\$19.00	\$20.00	*	*	Postpaid
Oil grain:	\$16.85	\$17.85	\$19.85	\$20.85	\$23.85	\$26.85	

*14 in. and 16 in. heights come with brown oil grain tops only. For lacing hooks add 50c.

Bean's Folding Sled

Strong enough to hold 1,000 pounds, yet weighs only 10 pounds. Originally designed to haul game into camp but is very useful for ice fishing, skating parties and for carrying food and equipment to camp. In case of accident may be used for hauling injured.

Length 48", width 18 1/2", height 6 1/2". Dimensions when folded — length 65 1/2" x 8 3/4" x 5".

May be carried on back seat of automobile.

When not in use may be folded and hung on wall taking very little space. Price, \$16.00 postpaid.



Re

Organized as a cooperative in 1938, Recreational Equipment, Inc. has grown to a membership of 79,000, with 2000 items listed in their catalog. These items are available at prices well below any other suppliers (with the exception of a few items, we're told). They are particularly strong on mountaineering equipment. Lifetime membership costs **\$1.00**.

[Suggested by Roland Jacopetti]

from Recreational Equipment, Inc.
 1515 North Avenue
 Seattle, Washington 98122



49 Nomadics

Adjustable Tent Poles. Lightweight aluminum 2-piece telescoping poles. Folding down to average 4'. Ideal for tarps, tent awnings, etc.
 B459C22 6' length, 18 oz. 1.85
 B489C23 7' length, 20 oz. 2.10
 B459C24 8' length, 22 oz. 2.45

[C] **Collapsible P-88 Tent Pole.** A four-section pole used with McKinley or Camper tents. Extends to 88" and collapses to 25" x 1 1/4" diameter. Weight 23 1/2 oz.
 6457C4 4.95

CO-OP CRUISER PACKS



The Cruiser contoured aluminum frame is the latest improvement in pack frames incorporating the strength and lightness of aluminum plus a contoured shape that makes backpacking a pleasure. We have designed a packbag made from a special 9 oz. waterproof nylon that is the heaviest weight pack cloth available, and is exclusive with us.

Cruiser Pack Frame. Made from tubular aluminum with heavy web back bands, padded shoulder straps and waist strap. Exclusive with us is the extra top bar for more rigidity.

Senior size frame, 15" wide, 31" long, for most adults, 2 3/4 lbs.

C346A6 10.00

Senior Co-op Cruiser Bag. The bag is 6" x 15" x 21" deep with a center pocket 1 1/2" x 10" x 8" deep, two side pockets 2" x 5" x 6" deep and two other pockets on the side which are 2" x 5" x 11" deep. All Cruiser bags attach to the frame by two cups suspended on the top rung and by two straps at the bottom, and are doubly reinforced at all stress points.

C678A10 Red or Sage nylon, 1 3/4 lbs. 12.95

C678A11 Red or O.D. cotton, 2 lbs. 9.95

[C] **Velcro Tape Closure.** The pull-apart closure that takes the place of a zipper. Although sold separately, both halves are needed for a closure. Grey color.

N315B14	1" hook, per foot	.35
N315B15	1" pile, per foot	.35
N315B16	2" hook, per foot	.70
N315B17	2" pile, per foot	.70

Mountaineering Medicine, a concise, handy guide to treatment of all sorts of ills and injuries in the mountains. By Dr. Fred Darville
 B389A75 1.00

DYNAMIC ROPE

In recent years, the Europeans have developed a new climbing rope using a solid core of parallel strands of nylon surrounded by a woven sheath. This has been found to be very strong and easy to handle, having less tendency to kink in use. Called "Dynamic," it has an elasticity of about 80% at rupture, thus giving greater protection to the climber during a fall. The tensile strength is, however, somewhat less. This new rope has been given the stamp of approval by the U.I.A.A. (Union International des Associations d'Alpinisme), who, through their testing, have set standards for maximum safety to climbers. Note: 9mm rope is recommended for double-line use.

[B] Mammot Dynamic Rope, Swiss made, red	
9mm x 120', 5 lbs.	B218A22 20.95
9mm x 150', 6 lbs.	B218A21 24.95

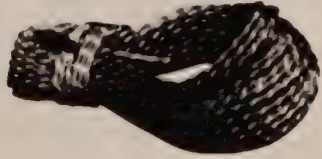

BULK PACKED FREEZE-DRIED FOOD

These larger quantities are suitable for expeditions. They must be re-sealed after only partial use to prevent spoiling.

3 Quarts in Polybags. Packed in cardboard cartons

Corn, whole kernel, 16 oz.	K404A13	2.95
Peas, garden, 16 oz.	K404A14	3.50
Strawberries, 8 oz.	K404A15	5.50
Peaches, 8 oz.	K404A16	4.50
Beef Patties, #10 tin, 1 3/4 lbs.	K404A33	9.75

#2 1/2 SEALED TINS

Alaska King Crab, net weight 4 1/2 oz. cooked K404A18 4.25

[A] [A] **Sierra Cup.** Stainless steel, all-time favorite, wire handle, nesting, 3 oz.
 H449C37 1.00

[B] **Nesting Aluminum Cup.** With folding wire handle, Swiss made
 3" diameter H206C22 .55
 3 1/2" diameter H206C23 .60

[C] **Bob Lane Cup.** Unique stainless cup, folds completely flat, does not leak, sturdy, weight only 3/4 oz.
 H536C7 1.25

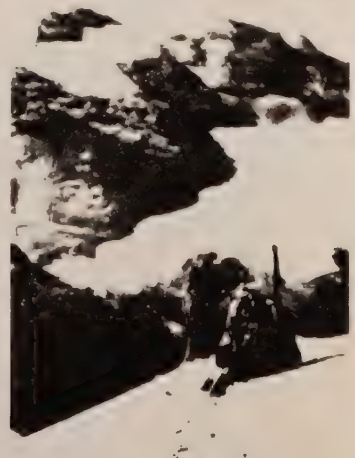

Mount Kennedy, 14,000'. In 1965, our men and equipment were on the first ascent of the peak named for the late President, and on the subsequent mapping research done in the area.

L.L. Bean cont.

Heavy Duty Belt

For hunters, fishermen and guides who require a solid leather belt for hard service. A fancy dress belt looks out of place on heavy hunting pants.



Made of high grade genuine cowhide with brass plated buckle
Two colors: Light Tan. Black. Sizes 24 to 48.

Width 1 1/4". Price, \$1.80 postpaid.

Bean's Insulated Boot Pant

Constructed same as Mackinaw of 21 oz. wool lined with quilted, foam rubber insulation. Extra warm, not bulky and hard wearing. Four deep, strong pockets with flaps on rear ones. Watch pocket, riveted suspender buttons and knit cuffs. Weight about 2 1/4 lbs. Dry cleanable.



Color: Bright Red and Black Plaid.
Men's sizes 30 to 50. Regular inseam.

Price, \$23.50 postpaid.

Wallabees

(For Men and Women)

A new design by Clarks of England for complete walking comfort. Fit perfectly on the first wearing.

Special "Nature Form" lasts fit the natural contours of the feet. Do not restrict them in any way yet provide firm support.

Glove leather uppers of full grained European calfskin suede. Extra thick, soft and supple. Wedge type soles of Plantation crepe rubber have a resilience not found in synthetic crepes.

Moccasin construction with hand sewed toe piece. Molded, orthopedic-type arch support enclosed in sponge rubber and bellows tongue and



vented leather insole. Firm heel counters, elasticized laces for snug, non-binding fit.

Color, Sand Suede.

Men's Ankle Height (above):

Sizes 7 to 13. Whole and half sizes. (No size 12 1/2.)

Medium width.

Price, Men's Ankle Height Wallabees, \$21.95 a pair postpaid.

Ladies' Low Cut (at right):

Sizes 5 to 10. Whole and half sizes.

Medium width.

Price, Ladies' Low Cut Wallabees, \$19.95 a pair postpaid.



Bean's Improved Sandwich Spreader

Professional quality of high grade stainless steel with mirror finish. Beautifully grained rose-wood handle. Brass rivets. Blade is stiff enough to dig out thick spreads or for turning. Flexible enough for easy spreading and frosting. Sharp serrated edge cuts sandwiches, cheese, vegetables, etc. Overall length 7 1/2". Blade 3 1/2".

Price, \$1.25 postpaid



Gerry Outdoor Equipment

The solidest reputation for innovative design in camping equipment belongs to Gerry Cunningham. (Now there's a statement that can be challenged. Do it.) Gerry packs, tents, parkas, sleeping bags, kiddie carriers, make up a well crafted well distributed line.

Gerry catalog Free

from:
Colorado Outdoor Sport
Equipment Co.
P.O. Box 344
Durango, Colo. 81301

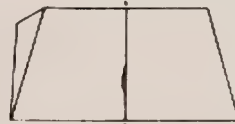
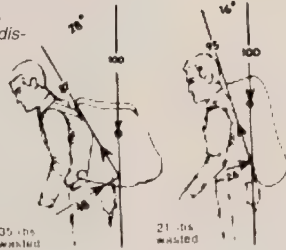

Durability. Crumpled-up newspaper will insulate. It will compress easily for packing. But once compressed, it will never regain its original thickness. Fine goose down, however, can be compressed lightly for months on end, yet it will always puff up to its original thickness within half an hour. Other materials tend to wear out, and lose thickness after each cycle of compression and release. Remember that thickness is warmth. So fluff up your bag as soon as the tent is up. Then fluff it up again before you crawl in. For more information on this subject send for my free booklet, "How to Keep Warm."

Dead air. All modern insulating materials depend on dead air to keep you warm. Any material that intercepts air at 1/4" intervals or closer will insulate sufficiently. There is no miracle insulation. If it deadens the air, one material is as good as another.

Thickness. The amount of insulation depends on thickness. To get a good night's sleep at 0° F., you need about 2 1/2 inches of dead air all around your body. Thickness can vary, but for every thin spot you need a compensating thick spot. Our Gerry sleeper thicknesses are measured under the same pressure of .034 oz./sq. inch as used in the Fed. Std. 148(a) Filling Power Test for Down (see Fig. 1). They are not fluffed up and then scanned across the top of the tubes.

Most manufacturers brag about how much down they put into a bag. We brag about how little we use. Comfort ranges for each sleeper are for temperatures at which even a person who sleeps cold will be warm.

Kaibab boots

Kaibab boots are the real thing: traditional Indian desert moccasins. Made of deerskin and horsehide, they are light, attractive, and durable — just the right amount of improvement over bare feet. Unfortunately there are innumerable imitations of Kaibabs, all terrible. The giveaway is the seam between sole and top: if the sewing is visible on the outside the moccasins are frauds and will fall off your feet in a few weeks. Real Kaibabs will last six months of steady use, and when you finally come through the soles, you can send the tops to Tucson for new soles (\$12.00) and get another six months. (One warning. Kaibabs on wet slick sidewalk are sudden death.)



49
Nomadics

Kaibab boots

\$18.75 mens
\$17.75 ladies

from
K
2
T
Lucksin
Stone



Foam pads

Lighter than an air mattress • Warmer than an air mattress • Can't leak and let you down • Compact — carries in same stuff sack as your sleeping bag • Pillow pocket at head end • Removable waterproof cover facilitates airing and drying.

1 Shortie 20-Pound Camp

Number: 9999 Weight: 1 lb. 2 ozs
Size: 36" long x 20" wide x 1 1/2" deep
Shipping Weight: 2 lbs.

\$8.00

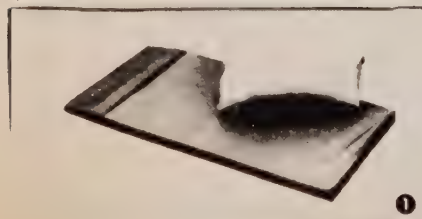

Gerry Kiddie seat

2 Lightest of all frame carriers • Aluminum tubing • Tough canvas duck seat supports baby snugly high • Can be used as car seat with adapter strap

Number: P952
Weight: 1 lb. 3 ozs Shipping Weight: 2 lbs. 10 ozs
\$11.00

his	lb.	oz.
Vagabond pack/frame	2	0
Wilderness sleeper	4	2
Shortie foam pad	1	2
Year-round tent/poles	5	0
1 1/2 qt. pot, lid, cup, spoon		10
3 lb. food	3	0
Poncho		14
TOTAL WEIGHT	16	12
hers	lb.	oz.
Vagabond pack/frame	2	0
Wilderness sleeper	4	2
Shortie foam pad	1	2
1 1/2 qt. pot, lid, cup, spoon		10
Aid kit, cord, flashlight		9
Poncho		14
1 lb. food	1	0
TOTAL WEIGHT	10	5



Hot Springs

It seems incredible that there would be such a book. Here are map location of all the known hot springs in the world, along with information on temperature, rate of flow, mineral content, and whether commercial or wild. You could travel the rest of your days from spring to spring, stopping at that Tatapani springs, on the west bank of the Sunkasi river ("3 springs forming small pool") 50 miles northwest of Mt. Everest, or the Hamman Ouled Sidi Abdeli ancient Roman baths, still flowing at 500 liters/minute, 81 F, 50 miles southwest of Oran, Algeria.

Published by the U.S. Geological Survey for a song, this directory fails to mention the plastic ice-water afterlife that awaits those who mess up wild hot springs.

Thermal Springs of the United States and Other Countries of the World—A Summary
Gerald Waring
1965; 383 pp.

\$2.75 postpaid
from Superintendent of Documents
U.S. Government Printing Office
Washington, D.C. 20402
WORLD EARTH CATALOG



The Explorers Trademart Log



Most periodicals that have anything to do with exploring are about it, for people who don't do it: useless. This magazine is for explorers, by explorers. The span of subject matter includes backpacking, diving, sailing, flying, spelunking, prospecting, archeology, photography, treasure hunting, mountaineering, and conservation. The magazine is new and growing. Somewhat jolly in tone, it is full of specific gossip on tools, access, and current explorations.

[Suggested by Mack Taylor]

\$3.00 per year (monthly)
from Explorers Trademart, Ltd.
P.O. Box 1667
Annapolis, Md. 21404

Thermal springs and wells in Argentina—Continued

No. on fig. 15	Name or location	Temperature of water (°C)	Flow (liters per minute)	Total dissolved solids (ppm)	Principal chemical constituents	Associated rocks	Remarks and additional references
55	El Saladillo de los Colorados.	34	Moderately large	4,560	Na, SO ₄ , Cl.	Precambrian(?) strata.	1 main spring and several small flowing wells.
56	Surgente de Copai de Guayapa, 15 km southwest of Patuquina.	22	Large	8,270	Na, SO ₄ , Cl.	do.	Flowing well. Water used for drinking by cattle.
57	Totoritas, in La Rioja. Pismanta, 8 km west of Jachal.	26; 40; 45		400; 356	NaHCO ₃ , Sr, SO ₄ , free H ₂ S.	Paleozoic strata.	Water used for bathing. 2 main springs. Water contains much Fe ₂ O ₃ and Al ₂ O ₃ . Ref. 912.
58	Quebrada de Huaco (Hedionda).	21-25	100	2,300-2,868	Na, SO ₄ ; much free H ₂ S.	Paleozoic limestone.	Several springs. Deposits of sulfur. Water used for bathing. Ref. 905.
59	El Volcan.	27.1		Moderately high	Na, SO ₄ , Cl; free H ₂ S.	Tertiary(?) deposits.	Water used locally.



FIGURE 15. California and Nevada—locations of thermal springs. (Chiefly from ref. 116)

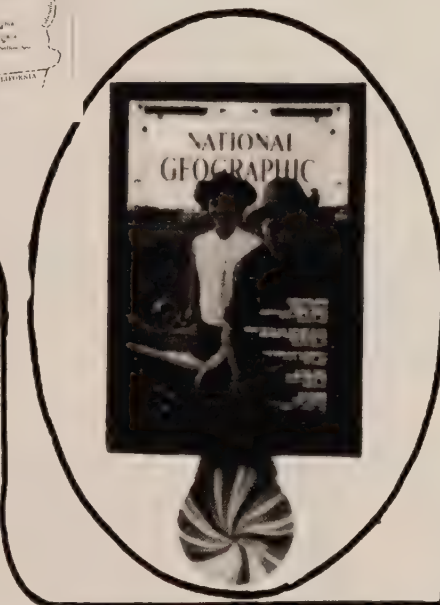
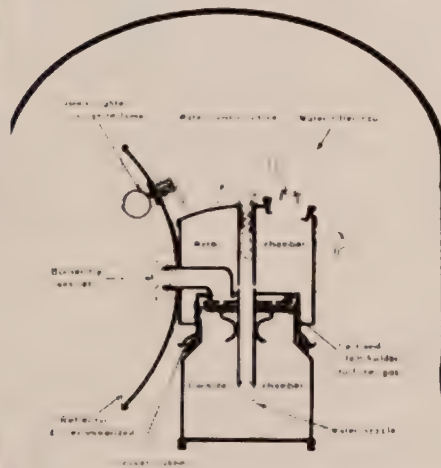
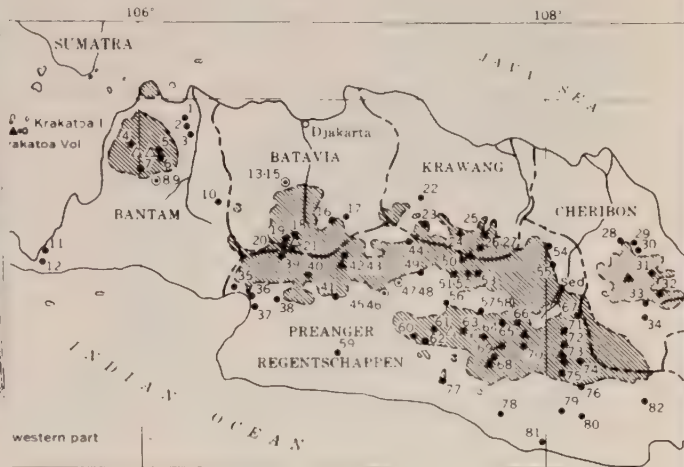

National Geographic

Everyone knows about National Geographic. This is just a reminder, or a tribute. Long live.

National Geographic

\$7.50 annual membership (\$9 outside U.S.)
12 issues

from National Geographic Society
Washington, D.C. 20036



Ship Out on a Freighter
DAVE COLLINS

The Viet Nam war has opened sea-going jobs for Americans with or without experience. All you need is good health, American citizenship, and a yen for far away places. Far East in this instance.

The "angle", and it is an angle, derives from the emergency crewing situation experienced by the Military Sea Transportation Service. M.S.T.S. is the ocean transportation organization for the Department of Defense. Approximately two thirds of the employees are military personnel. All ship's personnel are civilian merchant seamen of the non-union variety. Herein lies part of the "angle". No union means no seniority preference, therefore no waiting. It also means no job security and no union contract, however that shouldn't bother the casual seaman, because the pay and everything else is the same.

The other part of the "angle" involves a thing called the Merchant Mariner's Document which is a

prerequisite to employment on any American ship. Only during emergency situations will the M.S.T.S. accept applications from persons without a document. Viet Nam is just such an emergency and while it lasts the M.S.T.S. is helping new seamen to obtain their cards.

The Merchant Mariner's Document is issued by the Coast Guard and stays with the holder beyond his employment with M.S.T.S. Once you have it you can use it from then on, regardless of who you work for. By the way, non-union jobs do exist, and the man, who is on the scene, and has his "ticket" (M.M. Document), can usually find work. You can join the union, of course, and go for the long term benefits, however unions are in business for the career seamen and are not in the business of accommodating sometime sailors.

The no-budget voyagers of this country, have in the past, usually had to "go foreign" in order to

work their way to the far corners and exotic parts of the world, but now, for a little while, it can also be a money making proposition. Moreover, the money comes in double helpings anywhere within one hundred miles of Viet Nam. The shipping turn around in Viet Nam has in the past been notoriously slow due to poor port facilities, so this has meant hundreds of dollars extra to even the lowliest seamen. The extra money is in the nature of a hazardous duty compensation. It must be admitted though that the war has not been at all dangerous for the merchant seamen.

Anyone with a few months to spare and the necessary nautical desire can address initial inquiries to: Commander, Military Sea Transportation Services, Naval Supply Center, Oakland, California 94625.

Bon voyage!



Sierra Club

Sierra Club is currently going global in its considerations, publishing gorgeous books on non-U.S. wildernesses, promoting Earth national park, etc.

We aren't listing their exhibit-format books simply because they aren't strictly tools. They do publish useful specific locale books and if you're a member you get discounts on them. Other services to members include the monthly Sierra Club Bulletin and organized access to local and global wild places plus having a hand in obstructing dumb progress.

\$14.00 first year individual membership; \$9.00 subsequently

\$18.50 first year for husband and wife; \$13.50 subsequently

\$8.50 first year for member 12 to 21; \$3.50 subsequently

from
Sierra Club
1700
Berkeley, CA 94704



The Narrow Road to the Deep North

Following the example of the ancient priest who is said to have travelled thousands of miles caring naught for his provisions and attaining the state of sheer ecstasy under the pure beams of the moon, I left my broken house on the River Sumida in the August of the first year of Jyokyo among the wails of the autumn wind.

Determined to fall
A weather-exposed skeleton
I cannot help the sore wind
Blowing through my heart.

After ten autumns
In Edo, my mind
Points back to it
As my native place.

The Narrow Road to the Deep North and Other Travel Sketches
Basho
1689; 1966; 167 pp.

\$1.75 postpaid

from
City Lights Books
333
Berkeley, CA 94704

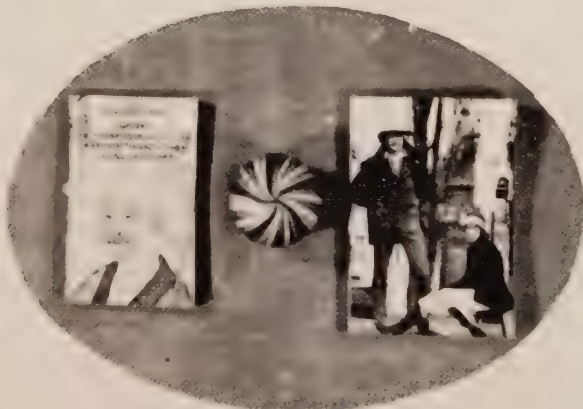

Trout Fishing in America

There was nothing I could do. I couldn't change a flight of stairs into a creek. The boy walked back to where he came from. The same thing once happened to me. I remember mistaking an old woman for a trout stream in Vermont, and I had to beg her pardon. "Excuse me," I said. "I thought you were a trout stream." "I'm not," she said.

A little way from the shack was an outhouse with its door flung violently open. The inside of the outhouse was exposed like a human face and the outhouse seemed to say, "The old guy who build me crapped in here 9,745 times and he's dead now and I don't want anyone else to touch me. He was a good guy. He built me with loving care. Leave me alone. I'm a monument now to a good ass gone under. There is no mystery here. That's why the door's open. If you have to crap, go in the bushes like the deer." "Fuck you," I said to the outhouse. "All I want is a ride down the river."

Trout Fishing In America
Richard Brautigan
1967; 112pp.

\$1.95 postpaid

from:
City Lights Books
1517
Berkeley Avenue
Berkeley, CA 94704
or
EARTH CATALOG

Sacred

To the Memory
of

John Talbot

Who at the Age of Eighteen
Had His Ass Shot Off
In a Honky-Tonk

November 1, 1936

This Mayonnaise Jar
With Wilted Flowers In It
Was Left Here Six Months Ago
By His Sister
Who Is In
The Crazy Place Now

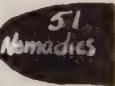

Toward a Theory of Instruction

We were going to carry Jerome Bruner's *Toward a Theory of Instruction* (\$3.95, Harvard University Press) here on account of his reputation, but on reading it I can't believe there isn't something better. If there is something better that you know about, would you tell us. If there isn't, would you mind reviewing this gentlemanly book? Fill this space, win a prize (\$10)

The Black Box

Officially, the name of this learning device is "The Inquiry Box." It was developed for Science Research Associates by Richard Suchman. It is a black wooden box (13 x 13 x 2"). On one side there are 3 small rectangular holds, the opposite side has one hole, and the remaining sides have 2 holes each. You don't know what's going on inside but something is. For example, there may be a string coming out of one hole and a rod sticking out of another hole. If you pull the string, the rod jumps. By pulling and pushing the things that stick out and by poking around inside with a stick you're supposed to figure out what arrangement of pulleys, pegs, springs and strings is inside.

There are an inexhaustible number of ways to arrange the insides with the components provided (see illustration). One kid can set up the "mystery arrangement" for another, you can set it up for them, they can set it up for you. At this certainly isn't limited to children. It's not at all a dull game for adults.

The Inquiry Box was designed for the teaching of theory building and theory testing to children. The teachers handbook gives you a very specific procedure to use the box by, but if you want to order (or make) just the box, you can learn a lot from using it any way you please.

[Suggested by Dick Suchman,
Reviewed by Jane Burton]



Inquiry Box set

\$19.96 Shipping Weight 4 1/2 lb.

from:
Science Research Associates, Inc.
211 Erie Street
Chicago, Illinois 60611

INQUIRY box theory sheet

Science Research Associates, Inc., 259 East Erie Street, Chicago
A Subsidiary of IBM **SRA**

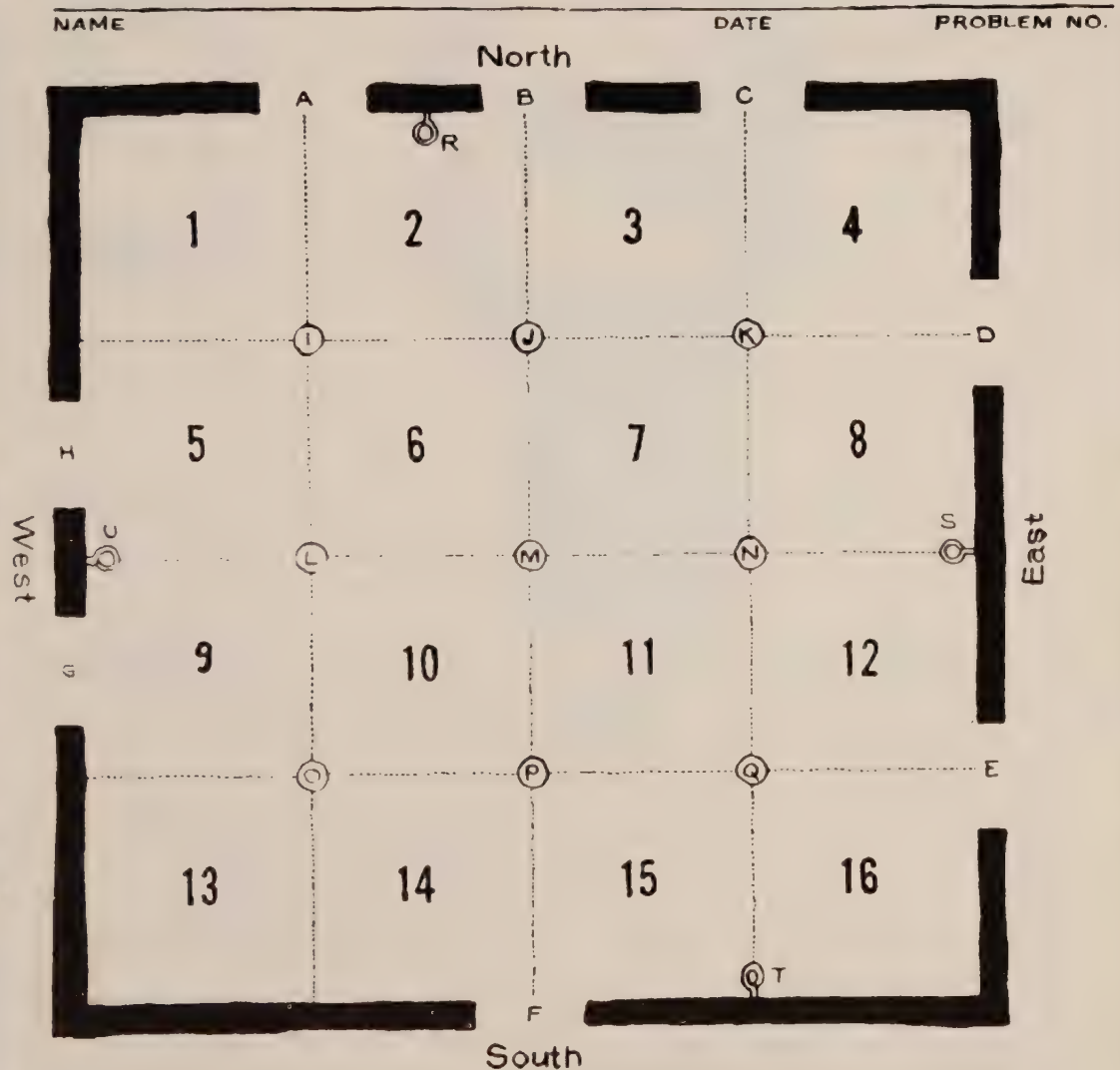

POSSIBLE LINKAGE COMPONENTS

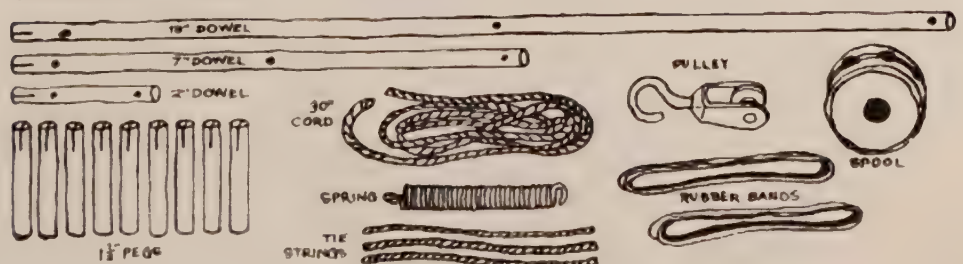

© 1967, Science Research Associates, Inc. All rights reserved. Printed in U.S.A.

Reorder No. 3-9383

Ita shærz with CUISENAIRE RODS a hie reputæshon for chænjing the formerly grim twø the nou-delættfoll. UEsually kids lerning twø read and riet or disceridg noe end bie the alodzick ov normal Inglish spellig. With the Ita alfabet, it's mor lodzickl and consistint. Riten lærgwidz becoms a twø insted ov a drag; the kids commens reedig and rietig on shær can them. læter on the mæk the shift twø normal ideotick spellig without pertickuelær stræn. Wun ov thes jeneræshons mæ not bother twø shift.

Ita has other applicæshons ic belieev. for wun, yø can beer riten lærgwidz better with it. An Ita translæshon ov FINNEGAN'S WAKE woud beë a reæl servis.

[A BETTER INFORMED REVIEW OF THIS SUBJECT IS NEEDED]

There's plenty of workbooks, manuals, library materials, etc. available from:
Initial Text Alphabet Publications, Inc.
20 East 100th Street
New York, N.Y. 10017

The best how-to-do-it introductory text I've seen is "The ITA Handbook for Writing and Spelling" Item No. 9-013. If you can get it by itself, it costs **\$1.50**. Promotional literature is free.

From the back cover of *Winnie-the-Pooh*

\$2.95 postpaid

published by E.P. Dutton
20 E. 10th Avenue South
New York, N.Y. 10003

The Initial Teaching Alphabet

devised in England by Sir James Pitman and introduced in 1963 in the United States, the Initial Teaching Alphabet (i t a) is used as a transitional teaching tool to help people learn to read. It has 44 symbols, each representing a sound, which take care of the phonetic irregularities of the traditional alphabet. After having learned to read with i t a, the beginner transfers with ease to the traditional alphabet.

The second year of experimentation with i t a in this country has shown remarkable effectiveness, not only in many first grades, but also in remedial reading, kindergarten reading readiness, and adult illiteracy classes.

Thær wox nœ wind twø blæ him neerer to the tree sœ thær hee stæd. hee cood see the huny, hee cood smell the huny, but hee coodn't kwiet reëh the huny.

after a littl whiel hee cauld down twø yœ. "Cristofer robin!" hee sed in a loud whisper.

"hællø!"

"ie thigk the bees suspect sumthig!"

"Whot sort ov thig?"

"ie dœn't nœ. but sumthig tells mee thæt thær suspishius!"

"perhaps thæ thigk thæt yø'r after thær huny?"

"It mæ beë thæt. yø never can tell with bees."

Thær wox another littl sielens, and then he cauld down twø yœ agæn.

"Cristofer robin!"

"yes?"



LIFE Science Library



Learn by leaving books around. These books anyway. They get picked up randomly, glanced into, and hours later you're still there on the john or wherever helplessly engrossed in diagrams explaining the design of musical instruments.

Rumor was, a few years ago during one of the Time-Life shuffles, that a lot of the best people there had gone into Time-Life books. I believe it. This series is well edited, illustrated, and authored. *Man and Space*, for example, is by Arthur C. Clarke; *Water*, by Luna Leopold and Kenneth Davis.

Most popular science books are badly behind the times. This series puts special emphasis on recent developments.

The books are only available by mail from Time-Life



PIECES OF A PICTURE
The object of this perception test is to fill in the missing pieces so that a familiar picture appears. If the test remains puzzling at normal reading distance, try it again from three or four feet before looking at the answer below.

A horse and rider
Light and Vision

Inc. A book comes every month or so, with a bill for **\$3.73**, and you either send the book back or pay up. Some are better than others, but we haven't sent one back yet.

While the outermost reaches of Jupiter's atmosphere are extremely cold, the internal temperature is probably quite high, due to a "greenhouse effect," in which the atmosphere acts as an insulator to hold in heat from the sun. Water might exist there, permitting the formation of the "organic soup" which sparked the first earthly seeds of life. It is now believed, in fact, that Jupiter's hydrogen-ammonia-methane type of atmosphere is what existed on the primitive earth in the days when life made its first appearance.

Although Jupiter's cloud cover is constant, most of the cloud markings we see there are quite transient, and disappear after a few days or weeks. However, there is one puzzling formation which has remained visible, on and off, for at least 130 years. This is the famous Great Red Spot, an oval shaped mass lying parallel to the planet's equator and not far from it, in the Southern Hemisphere. The Great Red Spot is considerably larger than our entire earth, yet it drifts around Jupiter like a gigantic raft; it has made several revolutions of the planet during the century that it has been under intense observation. The most popular theory holds that the Great Red Spot is a huge meteorological disturbance.

TWO LENSES IN ONE



Light and Vision
Bifocals - introduced to American in the 18th Century by Benjamin Franklin - help older people with rigid lens structure to focus at both near and far distances. The upper half of the spectacle lens gives slight correction for distant viewing. The lower half is for close-up work; it provides the increased refraction needed to compensate for the increasing rigidity - and the inability to focus - of the aging lens.

LIFE Science Library

from:
Time-Life Books, Inc.
Retail Sales Dept.
740 N. Michigan Ave.
Chicago, Ill. 60611

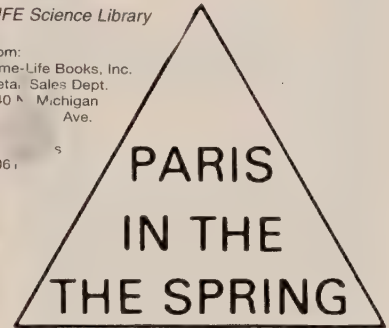

WHAT'S WRONG WITH THIS PHRASE?
At first glance, seemingly nothing. But with closer reading the repetition of the word **THE** becomes obvious. Because we generally read rapidly in word patterns rather than slowly, a word at a time, it is easy for the eye to skip over the extra **THE** and register the familiar phrase incorrectly.

Kaiser Aluminum News



Don Fabun is doing very well at his job of making Kaiser appear comprehensive and futuristic. The Kaiser Aluminum News that he edits comes out several times a year, each issue devoted to one large topic, such as communication, transportation, food crisis, etc. They are excellent compendiums of current thought, vividly illustrated and laid out. Best of all, they're free if you write Kaiser for single copies.

Inquire for their list at:
Public Affairs Department
Kaiser Aluminum and Chemical Corporation
Kaiser Building
Oakland, California 94604



The Road to Kwashiorkor
A 4-page booklet...
Inquire for your copy at:
Public Affairs Department
Kaiser Aluminum and Chemical Corporation
Kaiser Building
Oakland, California 94604

WFF 'N PROOF

The WFF 'N PROOF games came out of the ALL project (Accelerated Learning of Logic) at Yale Law School. This project was established in 1960 to develop materials to teach mathematical logic to elementary school students. The authors' first principle in designing the games was that they be fun to play.

The primary aim of WIFF 'N PROOF is to encourage a favorable attitude toward symbol manipulation activities in general and, incidentally, to teach something about mathematical logic and provide practice in abstract thinking.

[From the introduction to the WIFF 'N PROOF manual.]

WFF 'N PROOF is a series of 21 games. The first ones can be played by children (starting around age eight), the last ones are difficult enough to interest logicians. The first game can be bought separately under the name of just 'WFF'. It is the best game and children always like to play it. In it you learn what a WFF (well formed formula) is, and there is no nicer way of doing that. The rest of the games teach you about constructing logical proofs. They are more tedious and a good teacher can find ways of doing this which are more fun. There's no harm in getting the whole set, however, and using it as long as it works.

[Reviewed by Jane Burton]

WFF **\$1.50** postpaid
 WFF 'N PROOF **\$6.50** postpaid

from:
 WFF 'N PROOF
 P.O. Box 1
 New Britain, Conn 06501
 or book stores

Also worth investigating from WFF 'N PROOF are:

Tac Tickle **\$1.25** postpaid (We play it in bed)
 The REAL Numbers Game **\$1.25** postpaid
 On - Sets: The Game of Set Theory **\$4.50** postpaid
 Equations **\$3.50** postpaid
 The Propaganda Game **\$5.50** postpaid

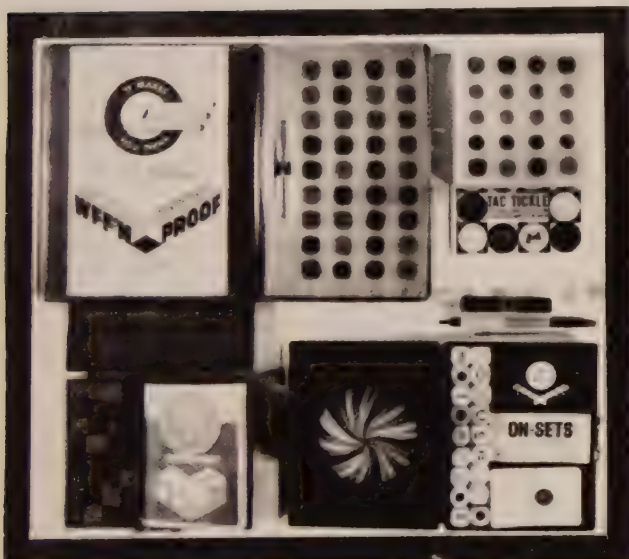

Dr. Nim

Arrange 15 matches in 3 rows with 3 in the first row, 5 in the second row, and 7 in the third row.

```

    ||| | |
    ||||
    |||||
    
```

This is a game for two players. You win by forcing your opponent to pick up the last match. When it's your turn, you play by taking as many matches as you like from any row (you may take the whole row if you like) but from one row only. This is the game of NIM and is actually a logical puzzle, for the first player can always win once he knows the winning strategy. The puzzle is to figure out that strategy.

Dr. Nim is a simple but amazingly clever computer which is programmed to play a perfect game of NIM with you. But Dr. Nim goes second so it is possible to beat him. He will win every time, however, until you figure out the winning strategy.

Dr. Nim is played with marbles instead of matches and the marbles are taken off the board by being released by a mechanical trigger. When it is Dr. Nim's turn to play you press the trigger once for him and then, if it's in his best interest to release more marbles, he will do so by running the marble over the trigger.

There's a good manual that comes with the game which tells you a little about computers and computer logic. It's the best way I know to give kids (or grown-ups) an idea of how computers work.

[Suggested and reviewed by Jane Burton]

from the Manual:

Man has a stream of consciousness, an identity, he thinks about himself, he philosophizes one minute and proceeds to solve a problem the next. He has a huge recognition memory that functions effortlessly. Having met a person only once, for example and seen him from only one angle, he recognizes him again in a different position. Of course, he has difficulty recalling his name, but his memory seems to be designed primarily for recognition, not recall. If he goes into a movie in the middle, he recognizes immediately the point at which he came in because he recognizes that he has seen and heard this part of the film before. Yet he cannot recall what the actors are going to say next. When they say the next sentences, he recognizes immediately that he has seen and heard them before, however.

from:
 Edmund Scientific Co.
 163 Fairport Building
 Barabara, New Jersey 08007

Dr. Nim
\$3.50 postpaid

or book stores



We Built Our Own Computers

Time was, kids built their own radios. Now it's rockets and computers, and so much the better. Once you've built one computer you have a far more sophisticated relationship with all computers. This British text, prepared by five school boys who indeed built their own computers, is an excellent introduction to hands-in technique.

[Suggested by Jane Burton]

We Built Our Own Computers

ed. A. B. Bolt
\$1.95 postpaid

from:
 Cambridge University Press
 32 Avenue of the Americas
 New York, N. Y. 10022



Electric Logical Computer Exeter

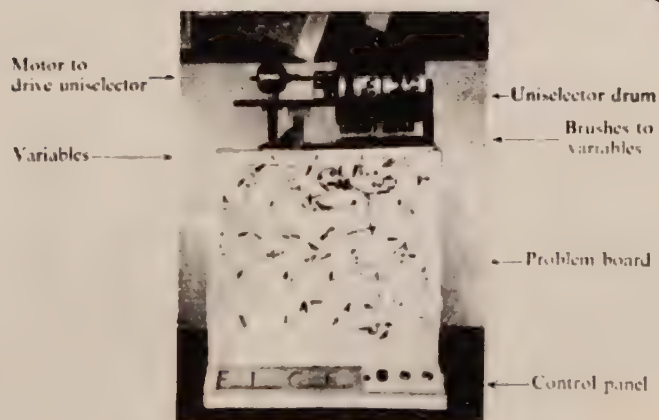

American Boys Handy Book

Dan Beard's *American Boys Handy Book* was first published in 1882. Out of print for a long time, Tuttle has finally reprinted it. This is barefoot-boy-with-cheek-of-tan stuff, detailed lore on how a boy may make his own world. Extraordinary book, highly recommended for funky schools or communities, especially if woods are handy.

[Suggested by Arthur Brand]

In a short time the room will be carpeted with red, all wool to remain undisturbed for a few years. The carpet through new holes made by these sharp teeth. A dog or a few cats be let into the room, that many rats will tell the tale of the massacre.

The Paper Pellet



The American Boys Handy Book

D. C. Beard
1882; 391 pp.

\$3.95 postpaid

from: Tuttle Co., Inc.
Ch: Vermont 05701
Rt: 1
or: ARTH CATALOG

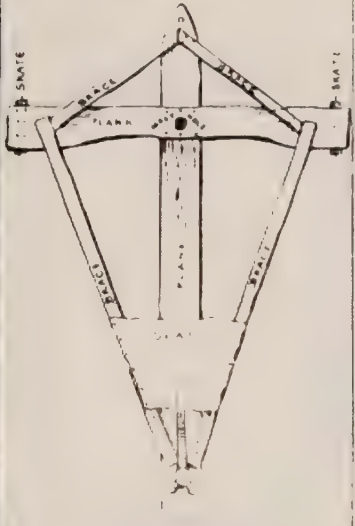

FIG. 188—Top View of Ice Boat

The Voice Disguiser

is made of a piece of corn-stalk about three inches long. After removing the pith cut a notch near each end, as shown in the illustration, upon opposite sides of the corn-stalk; upon the ends stretch a piece of fish-bladder or any thin membrane; a piece of thin tracing-paper will answer. With a large pin make a hole in each piece of membrane, as shown at A in the illustration. Now cover the notch, cut into the corn-stalk, with your mouth and laugh; the noise you produce will set you laughing in earnest. By placing your mouth over either of the notches and talking or singing, the voice is so changed as to be perfectly disguised, and if you sing a song through this instrument it sounds like some one playing on a comb covered with paper. The voice disguiser is very handy in Punch and Judy or puppet shows.



Top View of Hoop and Cross Wire.
Wick-fall.
Side View of Hoop showing Wick fall hung in place.

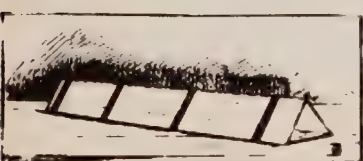

FIG. 93—Kaleidoscope

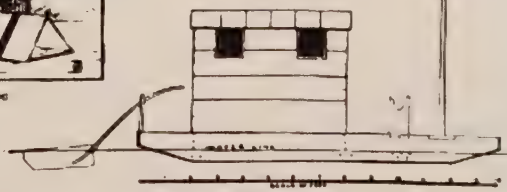

FIG. 91—Side View of Flat-Boat

Set a seat in front of the rowlock with a hole in it for the "jack-staff" to pass through. The jack-staff should be made so that it can be taken out and put in at pleasure. This can be done by...

Pioneer Posters

Cheap, good, educational, weird. They're a whole other kind of history than book history and better posters than most posters. Immense variety.

Catalog **\$0.10**

from: Historical Society
Pic: Tennessee 37748
He: ennessee 37748



- C140—TRAVEL POSTER—1854—boats, traveled inland & connected with railroads. Illustrated 17" x 11" 25c
- C141—LINCOLN ELECTION BROADCAST—picture Lincoln & Copper head snake unusual 17" x 11" 20c
- C142—LINCOLN—pencil sketch 3:27 65 shortly before death fine study 10c
- C143—BILL OF SALE—SLAVE—1667—Mass colony—very early document 20c
- C144—BALLAD—1844—handbill Famous murder Rhode Island unique worthy framing 15c
- C145—RECIPE—how make bad husband good 1795 almanac 10c
- C146—STEAM MOTOR CAR—Handbill—1888—illustrated—oddy 15c
- C147—STEAM BUOY—1870—handbill illustrated Will outspeed horse 15c
- C148—STEAM WAGON—1867—illustrated one of the earliest miles 25c
- C149—HISTORIC NEWS—set of 4 figt pages—1 1863, 2 Lincoln shot, 3 Spanish-Amer War, 4 1931 Depression prices Entire set 50c
- C150—AUCTION SALE LOTS—1843—Brooklyn—large—rare 40c
- C151—PLEDGE OF ALLIANCE—signed by G Washington at Valley Forge 1778 rare 20c
- C152—GETTYSBURG ADDRESS—in Lincoln's handwriting 15c
- C153—MENU—May 2 1865 black border A Nelson in Tears mourns Lincoln 15c
- C154—TEXAS DECLARATION INDEPENDENCE—1836—13 x 9 1/2 30c
- C155—TEXAS RECRUITING immediately armed & 20c
- C156—GEN'L GRANT to LI 20c
- C157—GEN'L LEE orders 1 20c
- C158—COMMISSION appo 20c
- C159—MAYFLOWER COMP Plymouth 25c
- C160—BILL OF SALE—18 By Gov Price 17 x 3 20c
- C161—WASHINGTON SHIRT made from life rare 20c
- C162—LINCOLN FUNERAL casket advertised with Rare oddy 35c
- C163—AMER REVOLUTION Phila Coffee House 1 20c
- C164—STAR SPANGLED B Rare 15c
- C165—MORMON BROADCASTI strations—circulated 25c
- C166—INTEGRATION PROE future all negro exc all negro football 1 20c
- C167—PATENT MEDICINE time table of cures head-ache—use magn 20c
- C168—CUSTERS LAST ST white pot medicine 20c
- C169—PAT MEDICINE medicine on horse 1 20c
- C170—BRADSHADE dated France in English 2 20c
- C171—BRADSHADE dated rare 65c
- C172—JULY 4th POSTER parody of celebration Civil War period 20c
- C173—AUCTION POSTER 20c

NEW COMPANY RULES

Office employees will daily sweep the floors, dust the furniture, chairs and showcases.

Each draftsman will bring in a bucket of water and a wrattle of coal for the day's business.

Draftsmen will each lay fill lamps.

clean chimneys, trim wicks. Wash the windows once a week.

Make your pens carefully. You may whistle like a your individual rats.

This office will open at 7 A.M. and close at 8 P.M. daily, except on the Sabbath, on which day it will remain closed.

Man employees will be given an evening off each week for working purposes, or two evenings a week if they go regularly to church.

Every employee should contribute from each pay a goodly sum of his earnings for his benefit during his declining years, so that he will not become a burden upon the charity of his betters.

Any employee who smokes Spanish cigars, uses liquor in any form, gets shaved at a barber shop or frequents pool or public halls will give up his position to support his worth, industrious, integrity and honesty.

The employee who has performed his labor faithfully and without fault for a period of five years in my service who has been thrifty and attentive to his religious duties, and is looked upon by his fellow men as industrious and law abiding citizen, will be given an increase of five cents per day in his pay, providing a just return of profits from the business permits it.

AT THE PRINCESS

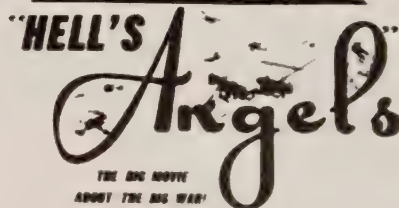

THE BIG MOVIE ABOUT THE BIG WAR!



A GRAND EXHIBITION OF THE EFFECTS PRODUCED BY INHALING NITROUS OXIDE, CARBONIC ACID, OR LAUGHING GAS!

will be given at the... Saturday is Positively the Last Day...
30 GALLONS OF GAS will be prepared and administered to all in the audience who desire to inhale it.
WHEN invited from the audience to protect those under the influence of the gas from injuring themselves or others. This course is adopted that no apprehension of danger may be entertained. Probably no one will attempt to fight.

- C190—BROADSIDE 1750 Mass—Murderer speaks on execution day Rare oddy 40c
- C194—MASS BAY COLONY 1711—Orders soldiers not to desert—impl 35c
- C195—NEW ENGLAND PROCLAMATION—Oct 17, 1766 THANKSGIVING day gives reasons 50c
- C196—MASS BAY COLONY 1711—warning about desertion 35c
- C197—7103 POSTER—Queen orders colonies not to trade France. Spain Rare 50c

- RULES 1854—Unusual control of private life, ca 30c
- 1905—Fur coat styles illustrated 25c
- BILL SHAW HANDBILL—scene Spanish-American 5c
- about 1870—illustrated—girl with biggest feet ants to marry oddy & true 35c
- 1778—Play postponed account indisposition 25c
- POWDER HANDBILL—Shows kitchen 1900—interest 5c
- HANDBILL—English, 5th Grenadier to fight 30c
- INGTON & HIS FAMILY—rare silhouette portraits 20c
- illustrates OLD BELLS church school fire 16 x 11 5c
- HANDBILL—1861—strong appeal to women to 25c
- LE—1854—Court orders 8 slaves sold 35c
- FIXTURES 1880—illustrated 20c
- MCNE—wear hat, 30 days hair grows back 1880 20c
- MCNE—1860—Lose weight, wear obesity belt plan 20c

Id Reward Posters

...gold rush in the most colorful chapter in history...
...courtesy of Wells Fargo...
...original rare 'REWARD POSTERS'...
...the five blank white paper suitable for framing 12 posters all different at 50 cents each or the entire set of 12 posters for only \$2—while supply lasts.

! CLOSE...
The following are limited...
16—CUSTERS LAST SNOT—Well...

Sense Relaxation

Becoming comfortable with touch requires patience and awareness. Experience what your attitudes are, how you touch, what your feelings are. Slowly, if you desire, you can change these reactions and allow yourself to enjoy touching not only others the floor, yourself, paper, food, trees, animals, flowers, life.

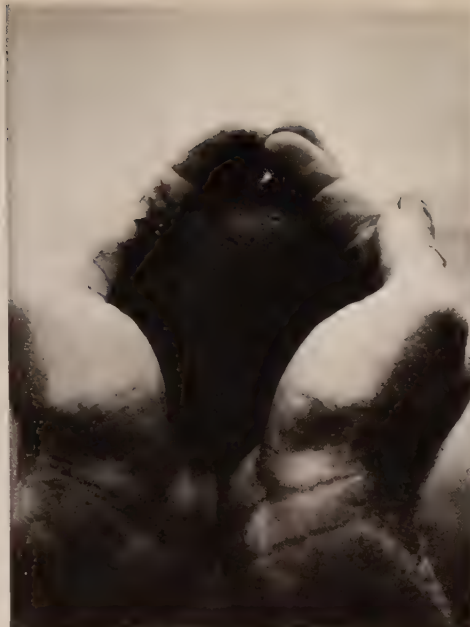

This is a book which is an experience while it teaches you how to have additional experiences. It is a combination of simple straight forward how-to-do-it prose broken by puns (to slow down your reading) plus sensual photographs of every exercise. Your first time through this book you will only glance at the words; the pictures are so compelling. The second and third times through you will read individual sections to find out what the pictures suggest. Finally you will begin to use this book to add touch, relaxation and pleasure to your life. This book gives very specific and easily followed exercises for individuals, couples, and groups to tune in to their own bodies and to all their senses. Gunther gives suggestions and techniques to energize, to tranquilize, and above all to increase awareness. It is a beautifully designed and executed book.

[James Fadiman]

Sense Relaxation - Below Your Mind

Bernhard Gunther, photography by Paul Fusco
1968: 191 pp.

from:
Co.
86'
Ne

ks
Avenue
N.Y. 10022

or most stores.

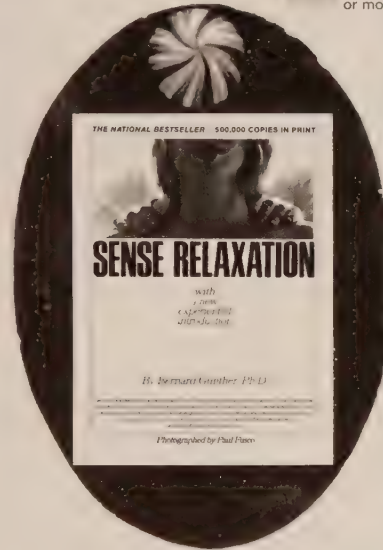

Zen Flesh, Zen Bones

A Collection of Zen and Pre-Zen Writings
compiled by Paul Reps
101 Zen Stories
The Gateless Gate
10 Bulls
Centering

Whose Zen do you like, Suzuki's, Blythe's, yours? Reps is best at yours.

Zen Flesh, Zen Bones
ed. Paul Reps
1961, 175 pp.

\$.95 postpaid

from
Dou eday
& any
5
F ave.
C City
L. T. Y.
11531
or
WHOLE
EARTH
CATALOG



If you like sweets and easy living, skip this book. It is about men tremendously intent on being reborn, on satori, enlightenment. It can happen to you. In a flashing moment something opens. You are new all through. You see the same unsame world with fresh eyes.

5. Consider your essence as light rays rising from center to center up the vertebrae, and so rises livingness in you.
6. Or in the spaces between, feel this as lightning.
7. Devi, imagine the Sanskrit letters in these honey-filled foci of awareness, first as letters, then more subtly as sounds, then as most subtle feeling. Then leaving them aside, be free.
8. Attention between eyebrows, let mind be before thought. Let form fill with breath-essence to the top of the head, and there shower as light.
9. Or, imagine the five-colored circles of the peacock tail to be your five senses in illimitable space. Now let their beauty melt within. Similarly, at any point in space or on a wall-until the point dissolves. Then your wish for another comes true.

63. When a moonless raining night is not present, close eyes and find blackness before you. Opening eyes, see blackness. So faults disappear forever.
68. Pierce some part of your nectar-filled form with a pin, and gently enter the piercing.

What is Zen?

One answer: Inayat Khan tells a Hindu story of a fish who went to a queen fish and asked: "I have always heard about the sea, but what is this sea? Where is it?" The Queen fish explained: "You live, move, and have your being in the sea. The sea is within you and without you, and you are made of sea, and you will end in sea. The sea surrounds you as your own being."

Another answer:

Meditation Cushions and Mats

Started by Alexandra Jacopetti, the Dharma Pillow Works has recently been sold to The San Francisco Zen Center. The product is the same, traditionally designed softness for your hard edges.

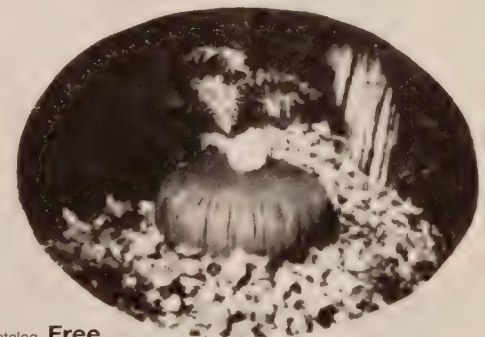

Catalog Free.

Zafu \$4.25 complete \$2.25 unstuffed. Available in 5-6" height, 4-5" height, or to order. Fabric is traditional black cotton or to order.

Zabuton (mat for added height and ease on knees) \$5.75

Also available: double Zabuton, baby mat, yoga mat, sleep mat, camping mat.

Groups, etc. purchasing six or more items get a 12% discount.

Order from D
4
E
Pillow Works
teenth Street
isco, Ca 94103

Self Hypnotism

On of the things that intrigues me most about hypnotism is that no one knows how it works-which accounts for some of its disrepute. No common factors, for example, have been found to pre-distinguish susceptibles from non-susceptibles. Black box business.

Lecron doesn't talk about any of this. He's concerned with how you can detect and de-suggest old imprinted hang-ups and suggest in new ones you like better. (One subject suggested herself larger breasts, and got them.)

Possibly the most general use of this book is its clear delineation of a simple avenue in a meditative technique without much dogma. There's a lot of hypnosis books; this is the best we've seen.

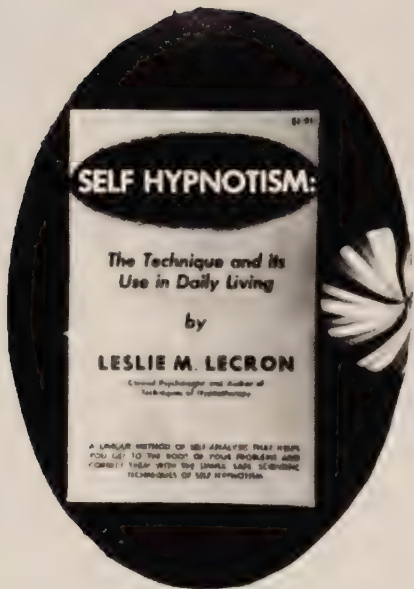

Self Hypnotism

Leslie M. Lecron
1964; 220 pp.

\$1.95 postpaid

from:
Princeton Hall, Inc.
E. 1st St. and Cliffs
New York, N.Y. 10011
or
WORLDWIDE BOOKS CATALOG

Psycho-cybernetics

This strange and gaudy volume will probably turn you off if you associate wisdom with subdued writing or humble exposition. However, if you can overcome your initial resistance to the high-pressure, breezy style and the sometimes excessive claims, it will be worth the effort. Dr. Maltz has outlined perhaps the easiest program of personality development and modification in print. It is easy because it contains nothing but the suggested exercises and the understanding that the motivation to change is still the most powerful tool.

This is not a book to read. It is a kit of tools to use in gaining control of your nature for whatever ends you desire. The author has made it clear that there is no virtue in being obscure or even in being poetic if it detracts from getting the reader off his ass and doing something about himself.

There is an assumption of a higher self or a core to one's being which tends toward realization or whatever term you prefer but understanding of this inner nature is not vital to using the book.

What we need to understand is that these habits, unlike addictions, can be modified, changed, or reversed, simply by taking the trouble to make a **conscious decision** - and then by practicing or "acting out" the new response or behavior.

Simple? Yes. But each of the above habitual ways of acting, feeling, thinking does have beneficial and constructive influence on your self-image. Act them out for 21 days. "Experience" them and see if worry, guilt, hostility have not been diminished and if confidence has not been increased.

So, why not give yourself a face lift? Your do-it-yourself kit consists of relaxation of negative tensions to prevent scars, therapeutic forgiveness to remove old scars, providing yourself with a tough (not a hard) epidermis instead of a shell, creative living, a willingness to be a **little vulnerable**, and a nostalgia for the future instead of the past.

If the above puts you off than this is not the book for your use. If this totally western way of dealing with yourself interests you, this book is far better than most of the other pop-entertainment books around.

[Suggested and reviewed by James Fadiman]

Psycho-cybernetics

Maxwell Malt, M.D.
1960; 256 pp.

\$2.00 postpaid

from:
Melvin Powers
87 West Boulevard
Hollywood, Ca 90069

or **\$1.00** postpaid

from:
Estate Sales Special
Ed. Schuster
63 Avenue
New York, N.Y. 10020

or most book stores

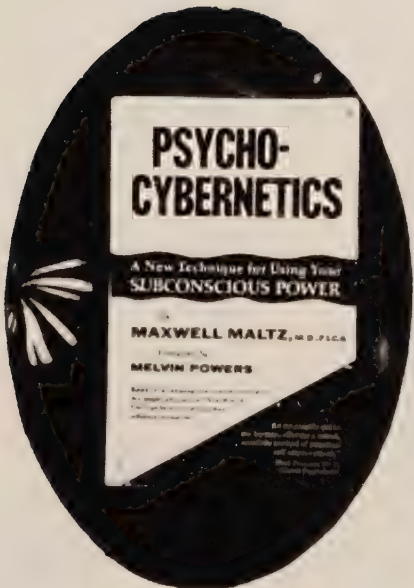

Now that you are comfortable you will listen closely to my voice and will follow all the suggestions given. This will teach you how to enter hypnosis and how to produce it yourself. Your eyes are now closed. Take another deep breath, hold it a few seconds and let it out.

The more you can relax, the deeper you will be able to go into hypnosis. Let all your muscles go as loose and limp as possible. To do this start with your right leg. Tighten the muscles first, making the leg rigid. Then let it relax from your toes up to your hip. Then tighten the muscles of the left leg. Let that leg relax from the toes up to the hip.

Let the stomach and abdominal area relax; then your chest and breathing muscles. The muscles of your back can loosen-your shoulders and neck muscles relaxing. Often we have tension in this area. Let all these muscles loosen. Now your arms from the shoulders right down to your finger tips. Even your facial muscles will relax. Relaxation is so pleasant and comfortable. Let go completely and enjoy the relaxation. All tension seems to drain away and you soon find a listlessness creeping over you, with a sense of comfort and well-being.

As you relax more and more, you will slip deeper and deeper into hypnosis. Your arms and legs may develop a feeling of heaviness. Or instead you may find your whole body feeling very light, as though you are floating on a soft cloud.

Now imagine that you are standing at the top of an escalator such as those in some stores. See the steps moving down in front of you, and see the railings. I am going to count from ten to zero. As I start to count, imagine you are stepping on the escalator, standing there with your hands on the railing while the steps move down in front of you taking you with them. If you prefer, you can imagine a staircase or an elevator instead. If you have any difficulty visualizing the escalator or staircase or elevator, just the count itself will take you deeper and deeper.

(Slowly) TEN- now you step on and start going down. NINE-EIGHT-SEVEN-SIX. Going deeper and deeper with each count. FIVE-FOUR-THREE. Still deeper. TWO-ONE and ZERO. Now you step off at the bottom and will continue to go deeper still with each breath you take. You are so relaxed and comfortable. Let go still more. Notice your breathing. Probably it is now slower and you are breathing more from the bottom of your lungs, abdominal breathing.

In a moment you will notice you hand and arm are beginning to lose any feeling and heaviness and are becoming light. If you are right-handed it will be your right arm, if left-handed, it will be the left.

The arm is getting lighter and lighter. It will begin to lift. Perhaps just the fingers will move first, or the whole hand will start to float up. It will float toward your face, as though your face was a magnet pulling it up until the fingers touch your face someplace. Let's see where that will be. The arm begins to bend at the elbow. It is floating upward. If it has not started of its own accord, lift it voluntarily a few inches to give it a start. It will continue to go up of its own accord with no further effort.

It floats on up toward your face, higher and higher. The higher your hand goes the deeper you will go. The deeper you go, the higher the hand will go. Lifting, lifting, floating up higher and higher. Going higher and higher. Now if it has touched your face let your hand go down to any comfortable position. If it has not touched yet, it can continue to float up until it does touch. You can forget about the arm while I tell you how you can put yourself into hypnosis whenever you may wish to do so.

You will use much the same method being used now. When you have made yourself comfortable, you will merely close your eyes and drift into hypnosis. But in your first three or four practice sessions it would help you if you first lit a candle and when you have made yourself comfortable would look at the flickering flame for two or three minutes. Then close your eyes.

Then you will think to yourself the phrase, "Now I am going into hypnosis." Then repeat to yourself the words, "Relax now" three times, saying them very slowly. As you do this your will slip off into hypnosis. You say nothing aloud, you merely think these words. When you have done this, take another deep breath to help you relax more and go through the relaxation just as you have done before. Tell your muscles to relax as I have done.

When you have finally relaxed your arms, imagine the escalator, elevator or staircase. Now you should count backward from ten to zero, including the zero. Count slowly. In your first four practice sessions repeat the count three times, as though going down different levels. With practice you need only count once.

Whenever you are ready to awaken all you need to do is think to yourself, "Now I am going to wake up." Then count slowly to three and you will be wide awake. You will always awaken refreshed, relaxed and feeling fine.

While you are in hypnosis if something should happen so you should awaken, you will do so instantly and spontaneously-something such as the phone ringing or a real emergency like a fire. You will awaken instantly and be wide awake and fully alert. Actually this would happen without such a suggestion being necessary, for your subconscious mind always protects you.

Now I will count to three and you will be wide awake, then if convenient you should then go through this formula for self-hypnosis and put yourself back in. You will remember the formula and go through it exactly as given. Now, awaken as I count. ONE. Coming awake now. TWO-almost awake. THREE-now you are wide awake. Wide awake.

A Yaqui Way of Knowledge

This book records the experiences of an anthropology student who becomes the apprentice of don Juan, a Yaqui indian "man of knowledge" who is also a "diablero", a black sorcerer. It is a profoundly disturbing book since it opens up areas and ideas we usually dismiss or deny. Don Juan, over a period of five years, teaches the author a little of his knowledge. He teaches through giving his apprentice various psycho-active plants: peyote, datura, and a mixture of psilocybin mushrooms, *genista canariensis*, and other plants. Each of these plants has its own way of teaching, its own demands and its own kind of power. For those of us who thought we understood psychedelic effects this book reveals the rudimentary state of our knowledge. For those of us who have dismissed magic as a combination of hypnotism and stage effects we are confronted with powerful and effective magic which seems irrefutable.

Don Juan himself appears as a powerful, indecipherable, wise man whose knowledge is both extensive and alien to our own. He offers to each of us the possibility of dealing with other realities, but he makes it clear that all these ways are dangerous, difficult and once entered, cannot be put aside as simply another experience.

The goal of his teaching is partially expressed as follows:

The particular thing to learn is how to get to the crack between the worlds and how to enter the other world. There is a crack between the two worlds, the world of the diableros and the world of living men. There is a place where these two worlds overlap. The crack is there. It opens and closes like a door in the wind. To get there a man must exercise his will. He must, I should say, develop an indomitable desire for it, a single-minded dedication. But he must do it without the help of any power or any man...

Not a book to be read for pleasure, a book which will effect you more than you may wish to be effected.

[Reviewed by James Fadiman]

(Why not read it for pleasure? It's frontier Boswell and Johnson. — SB)

"Don't get me wrong, don Juan," I protested. "I want to have an ally, but I also want to know everything I can. You yourself have said that knowledge is power."
"No!" he said emphatically. "Power rests on the kind of knowledge one holds. What is the sense of knowing things that are useless?"

He looked at me for a long time and laughed. He said that learning through conversation was not only a waste, but stupidity, because learning was the most difficult task a man could undertake. He asked me to remember the time I had tried to find my spot, and how I wanted to find it without doing any work because I had expected him to hand out all the information. If he had done so, he said, I would never have learned. But, knowing how difficult it was to find my spot and, above all, knowing that it existed, would give me a unique sense of confidence. He said that while I remained rooted to my "good spot" nothing could cause me bodily harm, because I had the assurance that at that particular spot I was at my very best. I had the power to shove off anything that might be harmful to me. If, however, he had told me where it was, I would never have had the confidence needed to claim it as true knowledge. Thus, knowledge was indeed power.

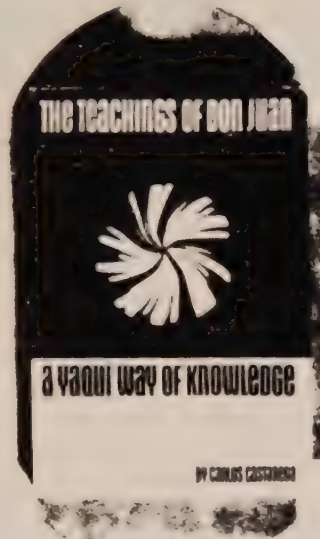

Once a man has vanquished fear, he is free from it for the rest of his life because instead of fear, he has acquired clarity — a clarity of mind which erases fear. By then a man knows his desires; he knows how to satisfy those desires. He can anticipate the new steps of learning, and a sharp clarity surrounds everything. The man feels that nothing is concealed.

And thus he has encountered his second enemy: Clarity! That clarity of mind, which is so hard to obtain, dispels fear, but also blinds.

"I say it is useless to waste your life on one path, especially if that path has no heart."

"But how do you know when a path has no heart, don Juan?"

"Before you embark on it you ask the question Does this path have a heart? If the answer is no, you will know it, and then you must choose another path."

"But how will I know for sure whether a Path has a heart or not?"

"Anybody would know that. The trouble is nobody asks the question and when a man finally realizes that he has taken a path without a heart the path is ready to kill him. At that point very few men can stop to deliberate, and leave the path."

"How should I proceed to ask the question properly, don Juan?"

"Just ask it."

"I mean, is there a proper method, so I would not lie to myself and believe the answer is yes when it really is no?"

"Why would you lie?"

"Perhaps because at the moment the path is pleasant and enjoyable."

"That is nonsense. A path without a heart is never enjoyable. You have to work hard even to take it. On the other hand, a path with heart is easy; it does not make you work at liking it."

You have the vanity to believe you live in two worlds, but that is only your vanity. There is but one single world for us. We are men, and must follow the world of men contentedly.

"But is this business of the dog and me pissing on each other true?"

"It was not a dog! How many times do I have to tell you that? This is the only way to understand it. It's the only way! It was 'he' who played with you."

"Let's put it another way, don Juan. What I meant to say is that if I had tied myself to a rock with a heavy chain I would have flown just the same, because my body had nothing to do with my flying." Don looked at me incredulously. "If you tie yourself to a rock," he said, "I'm afraid you will have to fly holding the rock with its heavy chain."

The Teachings of Don Juan: A Yaqui Way of Knowledge

Carlos Castaneda from Room 701
1968; 196 pp. University of California Press 25 West 45th Street
2 on Street New York, N.Y. 10036
\$5.95 postpaid E Ca 94720
OR
WHOLE EARTH CATALOG

Fundamentals of Yoga

Mishra has practised as general physician, surgeon and endocrinologist in India and the West and has a thorough knowledge of Western medicine as well as yoga. This makes his book invaluable to the student desiring a detailed scientific understanding of yogic theory and methods. The book contains several interesting diagrams of physical systems and psycho-physical planes of consciousness.

Being a practising teacher of yoga, Mishra writes in a forthright direct style and gives, in each chapter, exercises arranged in numbered steps, to practice the methods described. The physical, or *hatha yoga* methods are described in some detail, though still only as preparatory to the other types of exercises. Methods not usually described in other works on yoga — such as *tratakam* (concentrated gazing) and *nadam* (tuning in to inner sound-vibration) are also taught and given extensive treatment. There are chapters on "Techniques to Magnetize the Body", "Group Relaxation and Group Magnetism", "Postoperative and Post-meditative Suggestion", "Anesthesia Produced by Yoganidra", "Heal Yourself by Your Own Hormones and Tranquillizers" et al.

One might find fault with the book's somewhat excessive load of Hindu terminology, much of which is redundant, and of more interest to students of Indian culture than to practitioners.

This is probably the best book for those professionals and laymen who want to apply yogic techniques in physical and psycho-therapy both for themselves and others.

[Suggested and Reviewed by Ralph Metzner]

Fundamentals of Yoga
Rammurti Mishra
1959; 255 pp.

\$5.00 postpaid

from
The University Press, Inc.
L...rt
2... Avenue South
N...k, N.Y.

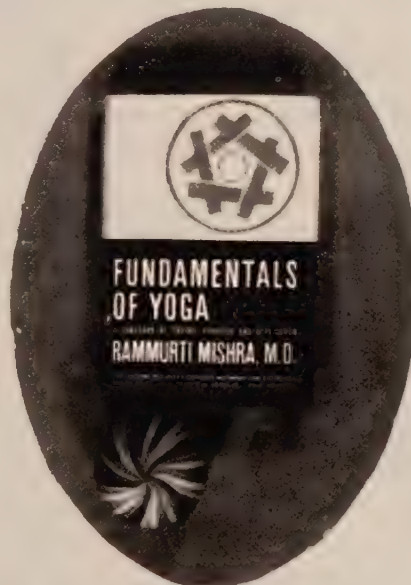

"Now you are in your native land. Now you do not know where your body is. The entire universe is in you and you are in the entire universe. Innumerable suns, stars, and planets are moving in you. Feel it, enjoy your real life." Complete silence.

1. Adopt an easy posture.
2. Relax your entire body.
3. Feel your heart pumping in the chest.
4. Hold your breath.
5. In a moment you will feel that heart rate and vigor of beat are increased.
6. With every heartbeat, the heart is sending energy to every part of the body. Feel it.
7. With increased heart rate and beat, energy is changed into electro magnetic pulsation and the entire body is filled with it. Feel it.
8. The entire is not magnetized, and the spiritual heart and spiritual consciousness are fully manifested in you. Feel them.
9. The whole body becomes the heart of the universe, and you feel that the entire body is pulsating as a single heart.
10. Gradually you forget the feelings of the physical body and you identify yourself completely with supreme consciousness.
- 11 Now you know that your consciousness is never a product of the body, but is manifested in the body.
12. Feel that your body is one point of manifestation of consciousness, but you are everywhere.

There are innumerable varieties of nadam, but they will be impractical for beginners. The following ten are the most useful and frequent:

1. Cin nādam: Like the hum of the honey-intoxicated bees; idling engine vibration; rainfall; whistling sounds; high frequency sound.
2. Cincin nādam: Waterfall, roaring of an ocean.
3. Ghanta nādam: Sound of a bell ringing.
4. Sankha nādam: Sound of a conch shell.
5. Tantri vina: Nasal sound, humming sound like that of a wire string instrument
6. Tala nādam: Sound of a small tight drum.
7. Venu nādam: Sound of a flute.
8. Mridamga: Sound of a big bass drum.
9. Bheri nādam: Echoing sound
10. Megha nādam: Roll of distant thunder



The Act of Creation

Koestler takes his notion of bisociation to be the root of humor, discovery, and art. I take it to be one of the roots of learning, subject to applications of method (on yourself or whomever).

Koestler is a scientist of some reputation by now. He's made contributions beyond the work of others that he's generalized from. This is the book that gave him the reputation.

There are two ways of escaping our more or less automatized routines of thinking and behaving. The first, of course, is the plunge into dreaming or dream-like states, when the codes of rational thinking are suspended. The other way is also an escape – from boredom, stagnation, intellectual predicaments, and emotional frustration-but an escape in the opposite direction; it is signaled by the spontaneous flash of insight which shows a familiar situation or event in a new light, and elicits a new response to it. The bisociative act connects previously unconnected matrices of experience; it makes us 'understand what it is to be awake, to be living on several planes at once' (to quote T.S. Eliot, somewhat out of context).

The first way of escape is a regression to earlier, more primitive levels of ideation, exemplified in the language of the dream; the second an ascent to a new, more complex level of mental evolution. Though seemingly opposed, the two processes will turn out to be intimately related.

When two independent matrices of perception or reasoning interact with each other the result (as I hope to show), is either a collision ending in laughter, or their fusion in a new intellectual synthesis, or their confrontation in an aesthetic experience. The bisociative patterns found in any domain of creative activity are tri-valent: that is to say, the same pair of matrices can produce comic, tragic, or intellectually challenging effects.

The re-structuring of mental organization effected by the new discovery implies that the creative act has a revolutionary or destructive side. The path of history is strewn with its victims: the discarded isms of art, the epicycles and phlogistons of science.

Associative skills, on the other hand, even of the sophisticated kind which require a high degree of concentration, do not display the above features. Their biological equivalents are the activities of the organism while in a state of dynamic equilibrium with the environment – as distinct from the more spectacular manifestations of its regenerative potentials. The skills of reasoning rely on habit, governed by well-established rules of the game; the 'reasonable person' – used as a standard norm in English common law-is level-headed instead of multi-level-headed; adaptive and not destructive; an enlightened conservative, not a revolutionary; willing to learn under proper guidance, but unable to be guided by his dreams.

The main distinguishing features of associative and bisociative thought may now be summed up, somewhat brutally, as follows:

Habit	Originality
Association within the confines of a given matrix	Bisociation of independent matrices
Guidance by pre-conscious or extra-conscious processes	Guidance by sub-conscious processes normally under restraint
Dynamic equilibrium	Activation of regenerative potentials
Rigid to flexible variations on a theme	Super-flexibility (reculer pour mieux sauter)
Repetitiveness	Novelty
Conservative	Destructive-Constructive

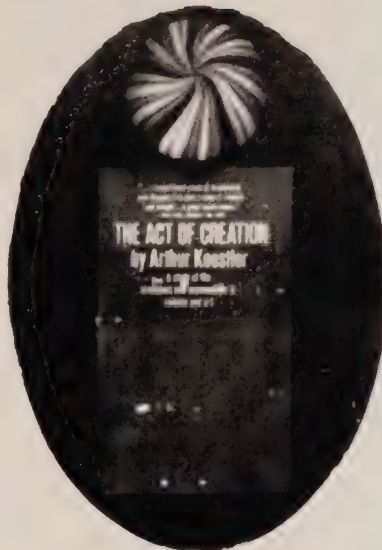

The Act of Creation

Arthur Koestler
1964: 750 pp.
\$1.25 postpaid
from
Doubleday Publishing Company, Inc.
7 West 17th Avenue
New York, N.Y. 10011
or most book stores.

I have coined the term 'bisociation' in order to make a distinction between the routine skills of thinking on a single 'plane', as it were, and the creative act, which, as I shall try to show, always operates on

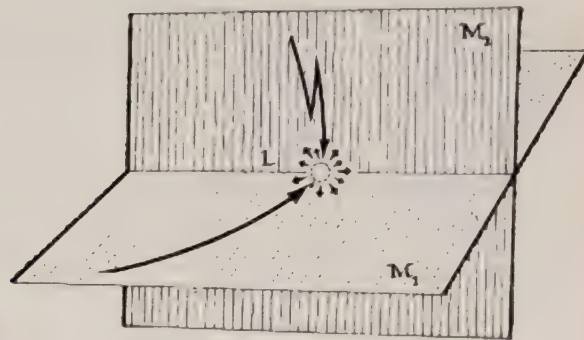

more than one plane. The former may be called single-minded, the latter a double-minded, transitory state of unstable equilibrium where the balance of both emotion and thought is disturbed.

Everybody can ride a bicycle, but nobody knows how it is done. Not even engineers and bicycle manufacturers know the formula for the correct method of counteracting the tendency to fall by turning the handlebars so that 'for a given angle of unbalance the curvature of each winding is inversely proportional to the square of the speed at which the cyclist is proceeding'. The cyclist obeys a code of rules which is specifiable, but which he cannot specify; he could write on his number-plate Pascal's motto: "Le coeur a ses raisons que la raison ne connaît point." Or, to put it in a more abstract way:

The controls of a skilled activity generally function below the level of consciousness on which that activity takes place. The code is a hidden persuader

This applies not only to our visceral activities and muscular skills, but also to the skill of perceiving the world around us in a coherent and meaningful manner. Hold your left hand six inches, the other twelve inches, away from your eyes, they will look about the same size, although the retinal image of the left is twice the size of the right. Trace the contours of your face with a soapy finger on the bathroom mirror (it is easily done by closing one eye). There is a shock waiting: the image which looked life-size has shrunk to half-size. Like a head hunter's trophy. A person walking away does not seem to become a dwarf – as he should; a black glove looks just as black in the sunlight as in shadow – though it should not; when a coin is held before the eyes in a tilted position its retinal projection will be a more or less flattened ellipse; yet we see it as a circle, because we know it to be a circle; and it takes some effort to see it actually as a squashed oval shape. Seeing is believing, as the saying goes, but the reverse is also true: knowing is seeing. 'Even the most elementary perceptions,' wrote Bartlett 'have the character of inferential constructions.' But the inferential process, which controls perception, again works unconsciously. Seeing is a skill, part innate, part acquired in early infancy. The selective codes in this case operate on the input, not on the output. The stimuli impinging on the senses provide only the raw material of our conscious experience – the 'booming, buzzing confusion' of William James; before reaching awareness the input is filtered, processed, distorted, interpreted, and reorganized in a series of relay-stations at various levels of the nervous system; but the processing itself is not experienced by the person, and the rules of the game according to which the controls work are unknown to him.

The I Ching

The *I Ching*, the Book of Changes, is a brilliant problem-solving device. A problem (or ignorance) generally consists of being caught in local cyclic thinking. To consult the oracle, the wisdom of chance (or synchronicity, no matter), is to step out of the cycle of no-change and address a specific story on the nature of change. You now have an alternative set of solutions that owe nothing but proximity to your problem. You make the associations, you find the way out. It's prayer.

I can't think of a more important and useful book than this one. It's famously ancient, poetic, deep, esoteric, simple, involving. It has been the most influential book on American art and artists in the last 15 years.

Most people know about it. We've included it here to point at the new smaller (unabridged) cheaper Princeton University Press version of the classic Wilhelm-Baynes Bollingen edition. The oracle method is still on page 721.

49. Ko/Revolution (Molting)



above TUI The Joyous, Lake
below LI The Clinging, Fire

The Chinese character for this hexagram means in its original sense an animal's pelt, which is changed in the course of the year by molting. From this the word is carried over to apply to the "moltings" in political life, the great revolutions connected with changes of governments. The two trigrams making up the hexagram are the same two that appear in K'uei, OPPOSITION (38), that is, the two younger daughters, Li and Tui. But where there the elder of the two daughters is above, and what results is essentially only an opposition of tendencies, here the younger daughter is above. The influences are in actual conflict, and the forces combat each other like fire and water (lake), each trying to destroy the other. Hence the idea of revolution.

THE JUDGEMENT
REVOLUTION. On your own day
You are believed.
Supreme success.
Furthering through perseverance.
Remorse disappears.

Political revolutions are extremely grave matters. They should be undertaken only under stress of direst necessity, when there is no other way out. Not everyone is called to this task, but only the man who has the confidence of the people, and even he only when the time is ripe. He must then proceed in the right way, so that he gladdens the people and, by enlightening them, prevents excesses. Furthermore, he must be quite free of selfish aims and must really relieve the need of the people. Only then does he have nothing to regret. Times change, and with them their demands. Thus the seasons change in the course of the year. In the world cycle also there are spring and autumn in the life of peoples and nations, and these call for social transformations.

THE IMAGE
Fire in the lake: the image of REVOLUTION
Thus the superior man
Sets the calendar in order
And makes the seasons clear.

Fire below and the lake above combat and destroy each other. So too in the course of the year a combat takes place between the forces of light and the forces of darkness, eventuating in the revolution of the seasons. Man masters these changes in nature by noting their regularity and marking off the passage of time accordingly. In this way order and clarity appear in the apparently chaotic changes of the seasons, and man is able to adjust himself in advance to the demands of the different times.



The I Ching

Translated by Richard Wilhelm, Cary F. Baynes
? B.C.; 740 pp

\$6.00 postpaid

from
Princeton University Press
Princeton, New Jersey 08540
or
WILEY-INTERSCIENCE ARTH CATALOG

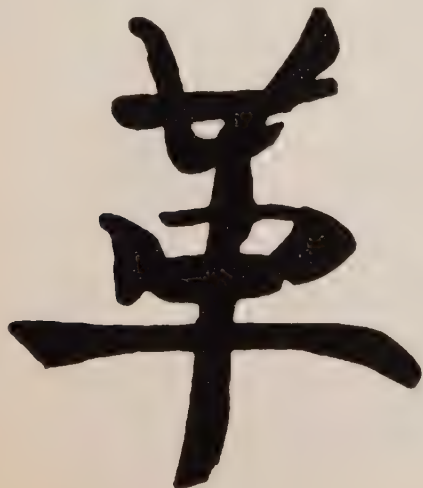

Access Information

The publications and products listed below by page number indicate the updated access or replacement of the item referred to in the 1968 WHOLE EARTH CATALOG with the sign of the living turtle.

3 Critical Path

Buckminster Fuller. 1981; 471 pp. \$15. St. Martin's Press.

Ideas & Integrities

Buckminster Fuller. Xerox. \$25.

Nine Chains to the Moon

Buckminster Fuller. Xerox. \$25.

No More Secondhand God

Buckminster Fuller. \$10.

Available from Buckminster Fuller Institute, 2040 Alameda Padre Serra #224, Santa Barbara, CA 93193, 805/962-0022, 800/967-MAPS.

www.bfi.com.

4 The Untitled Epic Poem on the History of Industrialization

Buckminster Fuller. Xerox. \$20.

Available from Buckminster Fuller Institute, 2040 Alameda Padre Serra #224, Santa Barbara, CA 93193, 805/962-0022, 800/967-MAPS.

www.bfi.com.

5 Powers of Ten

Philip Morrison and Phyllis Morrison. 1982; 150 pp. \$19.95.

Scientific American Library.

Powers of Ten: A Flipbook

1998; 154 pp. \$9.95. W.H. Freeman.

The Films of Charles & Ray Eames Vol. 1: Powers of Ten

21 minute video. 1989; \$39.95.

Pyramid Home Video, PO Box 1048, Santa Monica, CA 90406, 800/421-2304, 310/828-7577.

www.pyramidmedia.com.

The New World Poster

24" x 32" x \$14.95.

The Astronomical Society of the Pacific, 390 Ashton Avenue, San Francisco, CA 94112, 800/335-2624, 415/337-2624.

www.apsky.org.

Interactive Earth

CD-ROM. 1998; \$54.95.

Worldlink Media, 3629 Sacramento Street, San Francisco, CA 94118, 415/931-6952, www.earthvoyage.com.

Orbit: NASA Astronauts Photograph the Earth

Jay Apt, Michael Helfert, and Justin Wilkinson.

1996; 223 pp. \$21.95.

National Geographic Society.

7 Sensitive Chaos

Theodor Schickel. 2nd edition, 1996; 231 pp. \$29.95.

Rudolf Steiner Press c/o Anthroposophic Press, 3390 Route 9, Hudson, NY 12534, 518/851-2054, www.anthropos.org.

8 A Year From Monday

John Cage. 1967; 179 pp. \$17.95.

Wesleyan University Press.

Systems Research and Behavioral Science: The Official Journal of the International Federation for Systems Research and General Systems Yearbook

M.C. Jackson, editor. \$125/year (6 issues).

John Wiley & Sons, Journal Subscriptions Department, 1 Oldlands Way, Bognor Regis, West Sussex, PO19 1YF, UK.

+44 (1243) 843282, www.wiley.com. The yearbook is published as the journal's final issue of the year.

9 Notes on the Synthesis of Form

Christopher Alexander. 1964; 216 pp. \$15.50.

Harvard University Press.

On Growth and Form

D'Arcy Thompson. 1961; 364 pp. \$13.95.

Cambridge University Press.

11 Psychological Reflections

Carl Jung. 1973; 410 pp. \$17.95.

Princeton University Press.

The Human Use of Human Beings

Norbert Wiener. 1954; 199 pp. \$11.95.

Da Capo Press, 223 Spring Street, New York, NY 10013, 212/620-8000.

12 The Ghost in the Machine

Arthur Koestler. 1990; 379 pp. \$11.95.

Penguin Arkana.

The Futurist

Edward Cornish, editor. \$35/year (10 issues).

World Future Society, 7910 Woodmont Avenue, Suite 450, Bethesda, MD 20814, 800/989-8274, 301/656-8274, www.wfs.org.

BuckyWorks

J. Baldwin. 1996; 243 pp. \$19.95.

John Wiley & Sons.



14 Engineering a New Architecture

Tony Robbin. 1996; 138 pp. \$47.50.

Yale University Press.

15 Dome Cookbook

Steve Baer. 1968; 40 pp. \$12 (\$15 postpaid).

Trial and Error, PO Box 1327, Corrales, NM 87048, 505/899-2366.

Environmental Design Catalog

John Sailer, publisher/editor. \$32/year (6 issues).

299 Market Street, Suite 320, Saddle Brook, NJ 07663, 800/837-9337, 847/291-5224, www.edcmag.com.

16 Environmental Design & Construction Magazine

John Sailer, publisher/editor. \$32/year (6 issues).

299 Market Street, Suite 320, Saddle Brook, NJ 07663, 800/837-9337, 847/291-5224, www.edcmag.com.

25 I.D.: The International Design Magazine

Chee Pearlman, editor in chief. \$45/year (8 issues).

440 Park Avenue South, 14th Floor, New York, NY 10016, 800/284-3728, 212/447-1400, www.idonline.com.

National Technical Information Service Catalog of Products

NTIS, U.S. Department of Commerce, Technology Administration, NTIS, Springfield, VA 22161, 800/553-6847, 703/605-6000, www.ntis.gov.

Metropolis Magazine

Susan S. Szenasy, editor in chief. \$28/year (10 issues).

61 West 23rd Street, New York, NY 10010, 800/344-3046, 815/734-4151, www.metropolismag.com.

The Shorter Science and Civilization in China, Vol. IV, Part 2

Joseph Needham and Colin A. Ronan. 1994; 334 pp. \$35.95.

Cambridge University Press.

Other volumes of both the original and the shorter Science and Civilization in China are also available.

27 Atlas of Oblique Maps: A Collection of Landform Portrayals of Selected Areas of the World

Tau Pih Alpha and Janis S. Dettmar. 1988; 137 pp. \$4 (\$7.50 postpaid).

United States Geological Survey, Information Services, Box 25286, Denver Federal Center, Denver, CO 80225, 800/HELP-MAP, 303/202-4700, www.usgs.gov.

Brookstone Hard-To-Find Tools Catalog

17 Riverside Street, Nashua, NH 03062, 800/846-5000, 578/581-7113, www.brookstoneonline.com.

Jensen Tool Catalog

7815 S. 46th Street, Phoenix, AZ 85044-5399, 800/426-1194, 602/968-6231, www.jensentools.com.

Moving The Earth

Herbert L. Nichols, Jr. & David A. Day. 14th edition, 1999; 1400 pp. \$99.95.

Blasters' Handbook

17th edition, 1998; 577 pp. \$119 (\$123.95 postpaid).

International Society of Explosives Engineers, 29100 Aurora Road, Cleveland, OH 44139, 440/349-4004, www.isee.org.

28 Cats' Paws and Catapults: Mechanical Worlds of Nature and People

Steven Vogel. 1998; 382 pp. \$27.50.

W.W. Norton.

Life in Moving Fluids: The Physical Biology of Flow

Steven Vogel. 2nd edition, 1996; 488 pp. \$25.

Princeton University Press.

Home Power Magazine

Richard Perez, editor. \$22.50/year (6 issues).

PO Box 520, Ashland, OR 97520, 800/707-6585, 530/475-0830, www.homepower.com.

29 Van Waters & Rogers Catalog

6100 Canillon Point, Kirkland, WA 98033, 425/889-3400, 800/234-4588, www.vwr-na.com.

Bookmaking

Marshall Lee. 4th edition, 1998; 112 pp. \$60.

W.W. Norton.

Zone System Manual

Minor White. 1967; 112 pp. \$14.95.

Morgan and Morgan, PO Box 595, Airport Road, Keene Valley, NY 12943, 800/305-0766, 518/576-4423, www.morganmorgan.com.

30 Beginning Glassblowing

Edward T. Schmid. 2nd edition, 1998; 120 pp. \$24.95.

Advanced Glassworking Techniques, Edward T. Schmid, 1998; 320 pp. \$32.95.

both from Glass Mountain Press, 927 York Street, Bellingham, WA 98226, 360/733-3497.

Glass Notes

Henry Halem. 3rd edition, 1996; 291 pp. \$30.

Franklin Mills Press, PO Box 906, Kent, OH 44240-2303, 330/673-8632, www.glassnotes.com.

Living Materials: A Sculptor's Handbook

Alvin Andrews. 1988; 349 pp. \$34.95.

University of California Press, 133 North Euclid Avenue, Ontario, CA 91762, 800/555-3130, 909/984-6341, www.tandyaleah.com.

31 Tandy Leather and Crafts Catalog

133 North Euclid Avenue, Ontario, CA 91762, 800/555-3130, 909/984-6341, www.tandyaleah.com.

Elliott Greene Bead Catalog

37 West 37th Street, New York, NY 10018, 212/391-9075.

Beads and trimmings.

Patternworks Catalog: Yarn and Knitting Supplies

PO Box 1690, Poughkeepsie, NY 12601, 800/438-5464, 914/462-8000, www.patternworks.com.

34 Calculators

\$45 - \$265. Hewlett-Packard. Twelve models of scientific, financial and graphic hand-held calculators and Palmtop PCs.

Cybernetics

Norbert Wiener. 2nd edition, 1972; 212 pp. \$15.

35 Eye and Brain

R.L. Gregory. 5th edition, 1998; 258 pp. \$18.95.

Princeton University Press.

Education Automation

1992; \$6. Available from Buckminster Fuller Institute, 2040 Alameda Padre Serra #224, Santa Barbara, CA 93193, 805/962-0022, 800/967-MAPS, www.bfi.com.

37 Heathkit Educational Systems

Riverview Drive, Benton Harbor, MI 49022, 800/253-0570, 616/925-2899, www.heathkit.com.

Courses and support material for educational and industrial training.

Full Line Catalog

The Drawing Board, PO Box 2995, Hartford, CT 06104-2995, 800/527-9530, 860/379-9911.

38 American Cinematographer Magazine

Stephen Pizzello, executive editor. \$40/year (12 issues).

American Cinematographer Manual, Rod Ryan, ed. 7th edition, 1993; 585 pp. \$49.95.

The ASC Press, 1782 N. Orange Drive, Hollywood, CA 90028, 800/4480145, 213/969-4333, www.cinematographer.com.

Modern Video Production

Carl Hausman and Philip J. Palombo. 1993; 315 pp. \$50.63.

Addison Wesley Longman.

The Independent Film and Videomaker's Guide

Michael Wiese. 1998; 475 pp. \$29.95.

Michael Wiese Productions, 1128 Ventura Boulevard, Suite 821, Studio City, CA 91604, 800/833-5738, 818/379-8799, www.mwp.com.

39 Techniques of Television Production

Gerald Millerson. 12th edition, 1990; 566 pp. \$64.95.

Focal Press, 225 Wildwood Avenue, Woburn, MA 01801, 800/366-2665, 781/804-2500, www.fh.com/fp.

Chilton's Repair Manuals

\$22.95 - \$39.95. NP/Chilton's, 1020 Andrew Drive, Suite 200, West Chester, PA 19380-4291, 800/695-1214, 610/738-9280.

130 car care titles for do-it-yourselfers, including books for specific models and years.

40 Publishers Weekly

Nora Rawlinson, editor in chief. \$169/year (52 issues).

245 West 17th Street, New York, NY 10011, 800/278-2991, 310/978-6916, www.bookwire.com/pw.

Books in Print

9 volumes. 1999; \$550. CD-ROM version: monthly; \$1,195, quarterly; \$795, semi-annually; \$695.

R.R. Bowker, 121 Chanon Road, New Providence, NJ 07974, 888/269-5372, 908/464-6800, www.bowker.com.

Print Finders

38 Walworth Avenue, Scarsdale, NY 10583-1433, 914/725-2332, www.printfinders.com.

Searches by title, artist, theme or design needs.

41 Communities Directory

2nd edition, 1996; 440 pp. \$25 (\$28 postpaid).

Fellowship for Intentional Community, Route 1, Box 155-D, Rutledge, MO 63563, 660/883-5545.

Communities: Journal of Cooperative Living

Diana Leaf Christian, editor. \$18/year (4 issues).

Route 1, Box 155, Rutledge, MO 63563, 660/883-5545, www.ic.org.

Green Revolution

\$20 yearly membership includes the quarterly newsletter: School of Living, 432 Learman Road, Cochransville, PA 19330, 610/593-6988.

The Realist

Paul Krassner, editor. \$14/7 final issues.

Box 1230, Venice, CA 90294, 310/392-5848.

To be discontinued after six more issues.

42 Dune

Frank Herbert. Special edition, 1990; 536 pp. \$6.99.

Acce Books/Berkeley Publishing Group.

Groups Under Stress

Roland Radloff and Robert Heimreich. 1968; 200 pp. \$30.50.

Irvington Press, PO Box 286, Cooper Station, New York, NY 10276-0286, 888/267-7323, 603/623-5204, www.scry.com/ayser.

43 Merck Manual

Robert Berkow, M.D. ed. 17th edition, 1999; 2600 pp. \$35.

Merck Publishing Group, PO Box 2000, Rydvo - 217, Rahway, NJ 07065, 800/659-4600, 732/594-4600, www.merck.com.

18th edition will be published in March, 1999.

Finding and Buying Your Place in the Country

Les Scher and Carol Scher. 2nd edition, 1996; 414 pp. \$25.95.

Dearborn Financial Publishing, 155 North Wacker Drive, Chicago, IL 60606-1179, 800/638-0375, 312/836-4400, www.dearborn.com.

Rural Property Bulletin

\$16/year (12 issues).

PO Box 608, Valentine, NE 69201, 402/376-2617, www.cnweb.com/rural/.

Consumer Reports

Jacqueline Leo, editorial director. \$24/year (13 issues).

Consumers Union, 101 Truman Avenue, Yonkers, NY 10703-1057, 800/695-4051, 914/378-2000, www.ConsumerReports.org.

44 Online Access to Government Documents

www.access.gpo.gov/index.html.

Never Pay Retail: How to Save 20% to 80% on Everything You Buy

Sid Kirchheimer, ed. 1996; 482 pp. \$17.95. Rodale Press.

45 Loompanics Unlimited Catalog

\$5, or free with order. PO Box 1187, Port Townsend, WA 98368, 800/380-2230, 360/385-2230, www.loompanics.com.

The "lunatic fringe of the libertarian movement" provides how-to-survive books.

46 Survival Arts of the Primitive Paiutes

Margaret M. Wheat. 1967; 117 pp. \$17.95.

University of Nevada Press.

47 Camping and Woodcraft

Horace Kephart. 1917; 912 pp. \$14.95.

University of Tennessee Press.

The Rainshed Inc.: Outdoor Fabrics and Supplies Catalog

707 NW 11th Street, Corvallis, OR 97330, 541/753-8900.

The Backpacker's Handbook

Chris Townsend. 2nd edition, 1996; 30 pp. \$18.95.

McGraw-Hill.

Whole Earth

Access to Tools, Ideas, and Practices ▶ WINTER 1998, ISSUE 95

For the winter issue, we asked friends to contribute their thoughts. No testimonials, no nostalgia. I tried to steer the short essays just a bit (as if one could guide any of these intellects). I asked: what is a difference that might most make a difference on a subject close to your heart/mind? I implied the future, however conceived.

As with any party, some invitees sent regrets. Phoebe Gloeckner couldn't finish her cartoon because she gave birth. Paul Hawken disappeared into New Zealand. Jerry Brown was wired into the election. Lawrence Ferlinghetti became poet laureate of San Francisco. Some Whole Earth friends I didn't know and was a bit shy to pursue in their cloisters. On the other hand, new faces arrived. Walter Mosley, in town, swung by the Whole Earth offices one afternoon. Tony Serra found a few minutes in the midst of one more hair-raising trial. Feisty Jane Jacobs agreed to be interviewed.

In Whole Earth tradition, we've dropped in some of our favorite books of the last thirty years, along with factoids and artwork. Warning: this

is not a new 1998 catalog of everything excellent. There are no reviews and no attempts to be comprehensive. Just a party.

Compared to the pieces written for our tenth and twentieth anniversary issues, some friends sport a harsher and more political voice, frustrated by a lack of workable tools (especially for conflict resolution) and by our still-clumsy, embryonic skills for accomplishing good works. Something is roaming loose and a bit scary through many hearts and minds.

For me, on the other hand, working on this issue was another antidote to cynicism. How amazing that there is this group of humans willing to contribute their time and thoughts for little or no money; inspired to design and structure a legacy and keep it alive—just for hope, just for fun and experiential truth, just to be friendly and helpful, just to learn from each other, just to reduce the pain and suffering around them. *Gracias.* — Peter Warshall

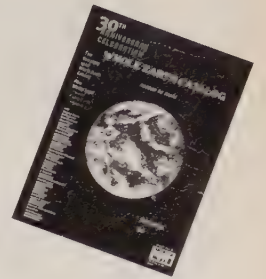

Editor
Peter Warshall
Managing Editor
Michael K. Stone
Assistant Editor
Lyssa Mudd
Contributing Editors
J. Baldwin, Linda Connor, Dan Imhoff, Dale Pendell, Liz Thompson
Graphic Designers
Stephanie Johnston, Monika Olson
Editorial Intern
Maren Fultz
Keyboard Wizards
Robin O'Donnell, Boleyn Baylor

Publisher
Alexander Gault
Business Manager
Anna Lee
Advertising Sales:
415/256-2800, ext. 221
Bookkeeper
Cynthia Ganey
Accountant
Pamela Netzow
Attorney
Albert Barsocchini

Point Foundation Board:
Esther Eidinow, Diana Hadley, Robert Hillman, Hunter Lovins, Danica Remy
Founder
Stewart Brand

Editorial Board: Steve Barnett, Sue Hall, Wes Jackson, Jaron Lanier, Jerry Mander, Vijaya Nagarajan, Shanyle Patton, Godfrey Reggio, Wolfgang Sachs, Gary Snyder, Andrew Weil

Address all editorial and business inquiries to: Whole Earth 1408 Mission Avenue, San Rafael, CA 94901.
Email: info@wholeearthmag.com
www.wholeearthmag.com



TABLE OF CONTENTS

2	DANCING PATTERNS		
	Living At The Techno-Humanist Interface	Jaron Lanier	..2
	The Long Now	Stewart Brand	..3
	Another Four-Letter Word: Gaia	Lynn Margulis	..4
	The Computational Metaphor	Kevin Kelly	..5
6	LEARNING		
	The Post-modern Preteens	Will Baker	..6
	Out of Love, Not Fear	Donella Meadows	..7
	Writing about the Universe	Walter Mosley	..8
	Mileposts	Mary Catherine Bateson	..9
	Rites of Passage: A Postmodern <i>Guernica</i>	Arthur Okamura	..9
	Red Pumps and Styrofoam Genders	Patrizia DiLucchio	..10
	Integrative Medicine	Andrew Weil, MD	..10
	Grief	Stephanie Mills	..11
12	PLANTS		
	Plant Teachers and the Path of Eve	Dale Pendell	..12
	Natural Systems Agriculture	Wes Jackson	..13
	A Dream of Oranges	Terry Tempest Williams	..13
	Visions for Rural Kentucky	Wendell Berry	..14
15	ANIMALS		
	Outside the Yuppie Zoo	Vine Deloria, Jr.	..15
	Destruction	Joanne Kyger	..15
16	PATHS		
	Code of the Warrior	Rick Fields	..16
	Paths Chosen	Phil Frank	..17
	The Executioner's Fork	JD Smith	..18
	sf.zendog@politics.heart	Peter Coyote	..19
20	MAKING STUFF		
	The Ultimate Swiss Omni Knife	J. Baldwin	..20
	When, If Ever, Is Enough Enough?	Steve Barnett	..21
22	WILDERNESS & CIVILIZATION		
	Nature As Seen from Kitkidizze	Gary Snyder	..22
	Differing With Dignity	Judith Martin, Miss Manners	..23
	To Make Sure that Things Go On	William H. Calvin	..24
	Whithering Politics?	Jay Kinney	..25
	Internet: The Illusion of Empowerment	Jerry Mander	..26
	KGB-ing America	Tony Serra	..27
	Softening the Intractable	Orville Schell	..28
29	DESIGNING/RESTORING		
	Vital Cities	Jane Jacobs / Stewart Brand	..29
	Redesigning Design Itself	Bill McDonough	..30
	Energy Lessons Learned And To Be Learned	Amory B. Lovins	..31
	The Garden Project	Cathrine Sneed	..32
	Living Technologies for a Living Planet	John and Nancy Jack Todd	..33
34	BEAUTY		
	Carnival (A Model for Culture)	Brian Eno	..34
	Lineages and Legacies	Anne Waldman	..34
	The Beauty of Disconnection	Malcolm Margolin	..35
	Navajo Nightway Chant		..35
36	BACKMATTER		

OPEN DANCING PATTERNS

LIFE AT THE TECHNO-HUMANIST INTERFACE

by JARON LANIER



Jaron Lanier's first love is music, which, in part, explains how his imagination discovered virtual reality machines, his acumen about theory, and his interest in the bioluminescent playfulness of giant squid photophores. His home overflows with wonderful flutes and stringed instruments. He is a pianist, computer scientist, composer, and clear and sweet-tempered essayist. This is a part of a longer piece on techno-visualization practices that can be used to bridge humanism and technology.

As I write this, a presidency is threatened, and a nation might be torn apart, over what seems at first to be nothing, and on closer inspection is an unresolved archetypal struggle about some version of "the sixties."

What was that incomparable sixties rush all about? I was a child when the Catalog came out (born 1960) and magic was wafting through the air. Everyone wrote better melodies then, and it seemed possible for anyone to achieve sensations that had never before been known by a human mind.

As I read the sacred old document, what strikes me most is its intoxication with cybernetics. The Catalog managed to find and promote a sexy book on chaos before there was a chaos theory, and was delightfully devoted to computers before computers became dramatic. Every topic was considered worthy of being graced with the cybernetic vibe; ecology, lifestyle, politics, even spirituality. In retrospect, it seems that it wasn't any set of events or inventions that created the "sixties" so much as a single idea: the cybernetic metaphor.

When the world is understood as information, as system, as pattern, as process, one can benefit from the unique rush of being able to see the whole vast expanse of reality from a commanding height. There it is: the source of all that light.

One big change since the time of the Catalog is embracing "out-of-controlness." The systems thinking in the 1968 Catalog is all about becoming aware of and learning to design using ever more general systemic layers of interpretation. This, and the HP calculator, are the only things in the Catalog that seem quaint. Even though the prospect was mentioned, somehow it hadn't quite sunk in yet that systems could be bigger than people, ultimately ungraspable. The Catalog reader was an individualist, out on the land, on the road, creating a new world out of thought and action. The nineties Catalog nostalgist, on the other hand, struggles in the eddies of economic and technological change, more opportunistic than farsighted.

Thus has the egoistic rush that drove the sixties mellowed into the more cautious mixture of awe and terror with which we apprehend the future.

Warhol, Fuller, Leary, and the rest experienced the same rush in their own ways. I knew many of them, and while to varying degrees I loved and admired these explorers, there was often a pit of doubt deep in me. My doubt was in part a premonition of "out-of-controlness anxiety," and in part a feeling that something vital was being left out. There was a distance, a slight sterility. The universe was thrillingly revealed, but the subjective moral center of a person somehow went missing. This little unit is utterly dispensable to rational understanding, of course; you have to choose to believe in it. In the cybernetic era, I decided, faith is the thing needed to bring people, not God, into existence.

It's enormously hard to make sense of the current political and cultural war. Why are the sixties hated to such a degree that a president who even slightly evokes them must be subjected to a public humiliation unprecedented in modern history? I wonder if at the core there might

not be a fear of soul loss. The Clinton haters fear that even a trace of the sixties represents a moral threat of the most profound variety. Similar paranoia has been directed at leftist, counterculture, or merely intellectual elements at many other times in American history, of course, but it's worth wondering if the paranoid Right might be afraid of something that is not entirely without basis, even if it is terribly inarticulate and dangerous in its expressions. Rational thinking is not the friend of fundamental life meaning.

There is no point in arguing across the divide, but I have been trying to find a middle path. At present we still know we are animals. We eat and sleep and reproduce in essentially natural ways, and, most dramatically, we think with natural brains, modified only by external experiences, however enriched those experiences might be by culture and information technology. There has to be some sense of conservatism, some anchor for what is human, if we wish to have science and technology serve humanity. That anchor is clear enough now—we are it. In the future we will have to choose.

Among my technophilic colleagues, there isn't any sense of resignation that humans must remain human in the far future. The human brain might become augmented through implanted and remote devices, genetic manipulation, enhanced embryogenesis, and artificial sensory organs. The human of the future might be able to think in ten dimensions with intuitive and experiential grace, instantly remember all the faces ever seen by any of her contemporaries via wireless net links, and see microwaves. She might even find within herself the capacity to know the new and unimaginable subjective color of microwaves.

In the long term, the augmentation of the brain, and the change in human identity that will go along with it, are probably inevitable, and could even turn out to be fun and lovely. But only if they occur slowly enough to allow for a persistence of human identity in the transition. To simply equip a new generation with vastly different brains is the equivalent of cultural suicide. This will be a real possibility demanding a real decision at some time in the future, and I would not be surprised to see it come up during the twenty-first century.

I know full well that my views on this aren't necessarily shared by all the other practitioners in the field, but I celebrate my colleagues on my own terms nonetheless. I perceive a distinct tradition of humanists in information technology from the earliest days. Doug Engelbart, the inventor of the mouse and much of the current conception of a computer, is the patron saint of this tradition. He once told me a story. It's the late fifties or early sixties, and Doug's chatting with Marvin Minsky, one of the fathers of Artificial Intelligence (and a treasured mentor to me when I was a young sprout). Marvin talks about AI and Doug says, "You're going to do all that for the computers? What are you going to do for the people?"

Technological humanists like Doug created the art of user interface design, became concerned with the political implications of network design, and initiated the craft of visualization. There is the technological culture to which I have pledged my allegiance. ∞

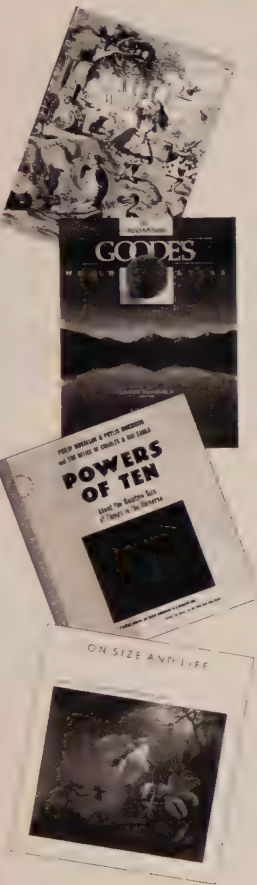

Alice in Wonderland & Through the Looking Glass. Lewis Carroll. 1946; 307 pp. \$15.99. Penguin Putnam. Goode's World Atlas. Edward B. Espenshade, Jr. and John C. Hudson. 19th edition, 1996; 368 pp. \$34.95. Rand McNally. Powers of Ten (see access, p. 62). On Size and Life. Thomas A. McMahon and John Tyler Bonner. 1987; 255 pp. \$32.95. W.H. Freeman.

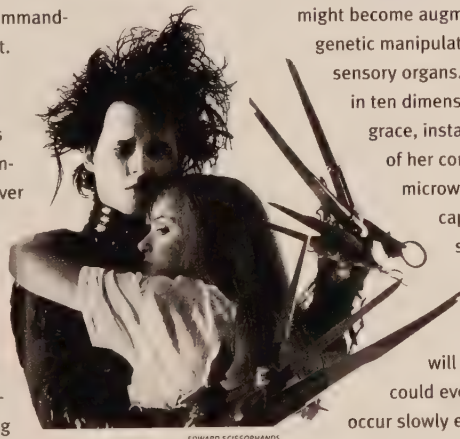

EDWARD SCISSORHANDS



THE LONG NOW

by STEWART BRAND

That phrase is from Brian Eno, the British musician/artist. If the photographs of the Earth from space gave us "the big here," and changed everything, what could we make or find that would deliver a sense of "the long now?" Responsibility, after all, lives more in time than in space.

How about a big, slow clock? And a very patient library?

We're building a 10,000-year Clock and a 10,000-year Library, under the auspices of the Long Now Foundation, over which I get to preside. The purpose of the Library is to manage information over centuries, ideally a hundred of them. (Why 10,000 years? That's the approximate age of civilization so far, starting from humanity's first farms and towns. Figure we're in the middle of civilization's story, with at least 10K years yet to go.) Some of the roles the Library might take on are: Very Long Term Scientific Studies; Mail to the Future; Responsibility Record (documenting the

debate on issues with long-term consequences and then re-examining those debates later, when the consequences have occurred); Golden Canon; Digital Continuity; and others. What would you like from a 10,000-year Library?

Other board members include Brian Eno, along with Danny Hillis, former Whole Earth editor Kevin Kelly, Peter Schwartz, Paul Saffo, Doug Carlston, and Esther Dyson. Hillis, who designed the current generation of massive parallel supercomputers, has invented a digital-mechanical Clock which can scale up to mountain size and be repaired with Bronze Age technology. Currently we're building the working prototype, eight feet high. We're looking for sites to build a very big city Clock (for visibility) and an extremely big desert Clock (for real longevity). ∞

I can be contacted at sb@gn.org. We have a web site, of course, at www.longnow.org. Long Now is a proper nonprofit foundation and invites contributions (of course) along with ideas and talent. We're based in San Francisco's Presidio and welcome mail at PO Box 29462, San Francisco, CA 94129. Alexander Rose is executive director. The phone is 415/561-6582.

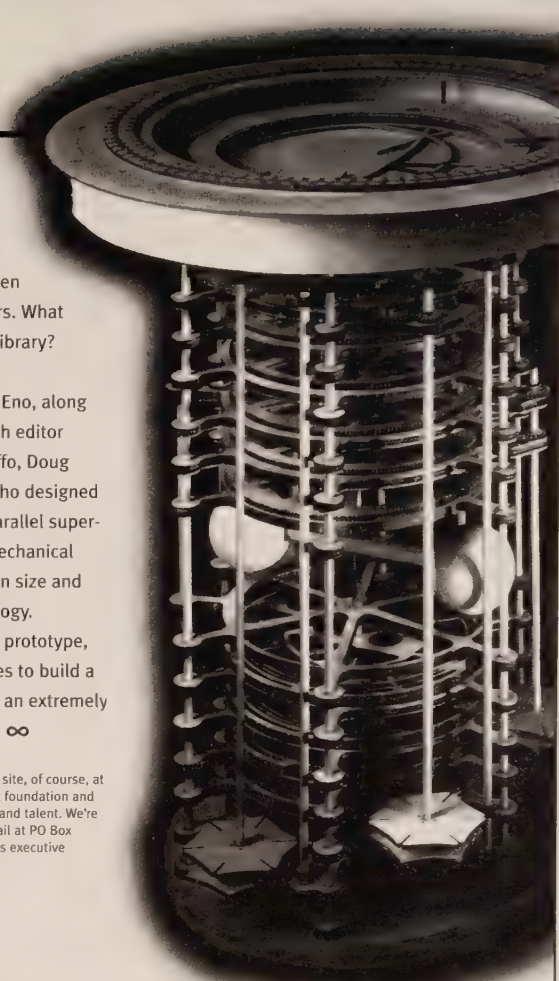

4 - 10,000-year Clock, version 1.0. This is a half-scale model (four feet high) in laser-cut wood of the prototype Clock designed by Danny Hillis. The bottom five rings are a new form of mechanical computer called serial bit adders. The results of their calculations advance the hexagonal Geneva wheels, which drive the top five rings, which translate for the display rings on top. Included in the display are the year (up to 12,000), the positions of the Sun and Moon, Moon phase, the horizon, and the locally visible starfield (which varies subtly over the 25,784-year Precession of the Equinoxes). The two balls in the middle are a torsional (rotating) pendulum. The prototype is being constructed of Monel steel, Invar steel, tungsten carbide, brass, and synthetic sapphire, with diamond coating for low-friction surfaces.

Calculating only twice a day, this will be the world's slowest computer, and the first to be Year 10,000-compliant

Before the Beginning, Martin Rees, 1998; 304 pp. \$13. HarperCollins. **Microcosmos**, Lynn Margulis and Dorion Sagan, 1986; 301 pp. \$11.95. University of California Press. **The Times Concise Atlas of World History**, Geoffrey Barraclough, Fourth edition, 1995; 184 pp. \$31.95. Hammond. **Guns, Germs, and Steel**, Jared Diamond, 1999; 480 pp. \$14.95. W.W. Norton. **Questioning the Millennium**, Stephen Jay Gould, 1997; 161 pp. \$17.95. Random House. **The Clock of the Long Now: Time and Responsibility**, Stewart Brand. To be published 1999; Basic Books. **Future Survey**, Michael Marien, editor. \$79/year (12 issues). World Future Society, 7910 Woodmont Avenue, Suite 450, Bethesda, MD 20814, 301/656-8274, 800/989-8274, www.wfs.org/wfs.

Below: Classic time representation as space (vertical) and time (horizontal) Yearly cycle of Japanese beetle Yearly cycle of Japanese beetle Recurrent time is measured by intervals (a year, a month)

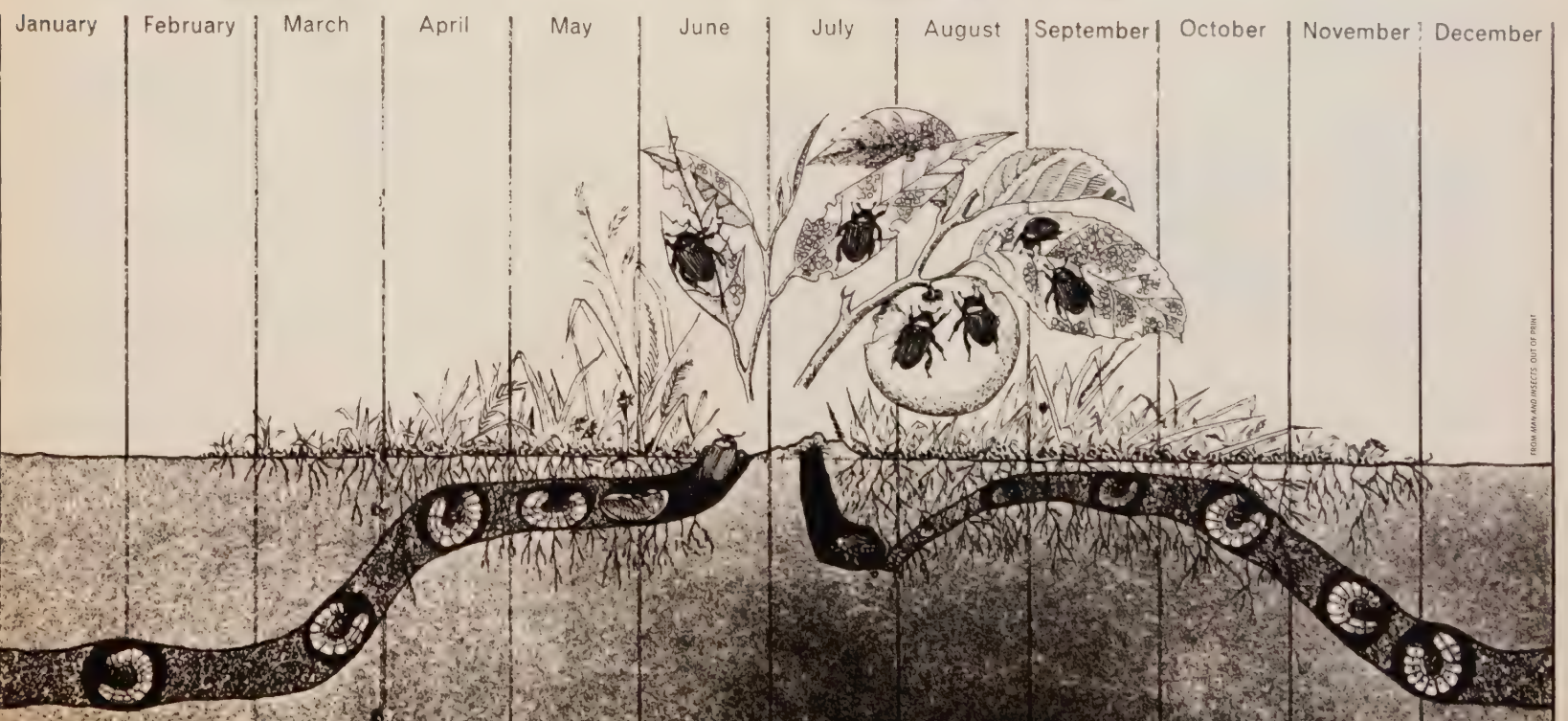

FROM MAN AND INSECTS OUT OF PRINT

ANOTHER FOUR-LETTER WORD: GAIA

by LYNN MARGULIS

Lynn is the most imaginative empirical scientist of cell evolution alive. Her work—from the Gaia Hypothesis to cell symbiosis—has revolutionized conceptual thinking on the microcosmos. She has continually refused to be bound by academic conceptual boxes. The educational materials Lynn has written and produced for general audiences have vividly altered high school and college curricula. I've said it before: she and James Lovelock are long overdue for a Nobel Prize.

I met Jim Lovelock for the second time in 1972. By then, he had talked enough for me to obtain a glimmering notion of his Gaia idea. As a committee member on various advisory boards for NASA, he was preoccupied, in his tinkery sort of way, with the problem of how one could objectively determine if life existed on Mars. What was obvious to him, after measuring reactive gases of biological origin such as ammonia, methane, and nitrogen and sulfur oxides, was that the air was loaded with exudates of life. These gases were accompanied by many other detectable trace compounds such as terpenes (piny essences), volatile amines (garbage smells), and methyl bromide (seaweed odor). Yet, as every chemistry student knows, all of these reduced organic compounds react readily and easily with oxygen and, from the point of view of chemistry alone, they should not be present for long in air samples. This thinking led Lovelock to the unassailable conclusion that the search for life on Mars should mainly be a thorough gas analysis that not only identified every gaseous component of Martian air but also measured their fluxes: the rate at which each was produced and removed. He figured: because the Earth's air is made of highly reactive mixtures, it shows the unmistakable presence of life. He suggested looking for reactive mixtures, or at least changes in gas concentrations, in the atmospheres of Mars and other planets, to see if any explanation beyond chemistry and physics would be required for understanding them.

As we talked about the biological effects of life on a planetary scale we made each other aware of the fact that all live beings produce and remove gas. All life requires the production of some gases and the removal of others (for instance, plants release oxygen and carbon dioxide to the air; animals and plants remove oxygen from the air). Microbes produce and remove a great range of other gases as well. Yes, we concluded with enthusiasm, the atmosphere is the circulatory system of the biosphere.

After making some conversational "Interactive Lecture (IAL)" tapes with Dr. Stewart Wilson, inventor the IAL system, we became more excited about the idea. By then Lovelock had published with Peter Liss and Dian Hitchcock on "detection of life throughout the atmosphere." Lovelock complained that no one seemed to understand what he was saying. In his frustration he turned to his neighbor, the novelist William Golding, for "a good four-letter word to focus the attention of his scientific colleagues on the Earth as a system." Golding suggested "Gaia."

When we first recorded our preliminary Gaia conversation, Stewart Wilson failed to engage one of the two recording buttons. He never did figure out what went wrong, but we had talked the entire day and not a word besides "testing, testing" had been recorded. We had two choices:

forget it or rerecord two days hence, just prior to Lovelock's takeoff from Logan Airport. We opted for the latter. The consequence of our decision was striking. The new, far finer, shorter, and better-organized dialogue inspired us to write up these ideas for scientific publication.

We wrote our first Gaia paper on life as the circulatory system of the atmosphere as a short, readable statement, in the style of the *American Scientist*, which we circulated to many scientific colleagues and friends for perusal and suggestions. After an unconscionably long wait, *American Scientist* rejected the article. We sent it out to others; while it was incubating, I received a call from Stewart Brand, founder and then-editor of *CoEvolution Quarterly*. Brand proved to me that he was all right, and no kook, because he already was friends with Phylis and Phil Morrison (extraordinary science teachers and writers, he for over thirty years as *Scientific American's* book reviewer). In his inimitable fashion, Stewart wasted no time: "I want to publish your paper with Lovelock." I asked him how he planned to review, edit, and change it. He said he liked it as it was. He was not a scientist and had no intention of altering it. He would publish the entire piece, illustrations, tables, and all. I was amazed. I blurted out, "But no scientist reads CQ. No one will trust our science if our work appears in your magazine before publication in a professional journal!" I remember distinctly his unambiguous response: "What do you care what people think? You want to see the Gaia idea out, don't you?"

Thus began the life of the Gaia hypothesis independent of Lovelock, of me, and of the scientific community. Of course work went on. The ideas, boosted mightily by Jim Lovelock's 1979 Oxford University Press book *Gaia: A New Look at Life on Earth*, were discussed in some scientific quarters. Within the evolutionist establishment, led primarily by Oxford University's Richard Dawkins, they denigrated, derided, and ignored Gaia as if she were an old witch. In the end, the scientific community of scholars co-opted our scientific ideas (to our delight). Still railing against the G-word (Gaia), they infiltrated their research with G-concepts. Atmospheric chemists, environmental scientists, planetary astronomers, geophysicists, geomorphologists, geographers, ecologists, and the public called this new view of our living planet "Earth System Science." ∞

Gaia Realms

Temperate seashore — rocky, sandy, and muddy; sunlit surface



Temperate forests, lakes, and rivers; sunlit surface



Deserts and high mountains; sunlit surface



Tropical forest; sunlit canopy

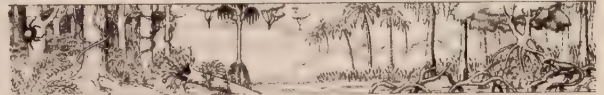

Tropical seas, reefs, continental shelves and slopes, and seashore; sunlit to depths of 200 or fewer meters

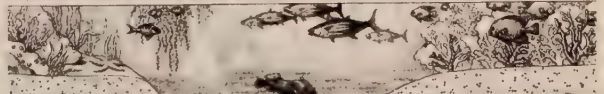

Tectonically active anoxic environment; sunlit surface

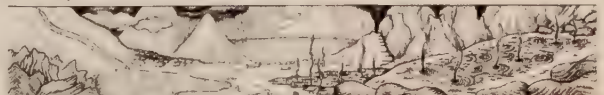

Abyss at tectonically active ocean rift zone; sunlight absent

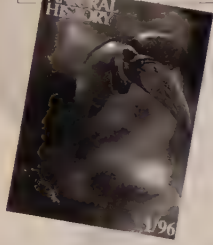
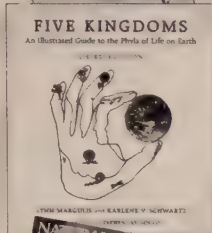

The Ages of Gaia: A Biography of Our Living Earth. James Lovelock. 1988; 272 pp. \$12. W.W. Norton. **Five Kingdoms: An Illustrated Guide to the Phyla of Life on Earth.** Lynn Margulis and Karlene V. Schwartz. 3rd edition, 1998; 448 pp. \$31.75. W.H. Freeman. **Natural History: A Monthly Magazine of Natural History.** Bruce Stutz, editor. \$30/year (10 issues). PO Box 5000, Harlan, IA 51537-5000, 212/769-5500. **The Psychoanalysis of Fire.** Gaston Bachelard and Alan C. M. Ross. 1964; 115 pp. \$13. Beacon Press. **World Fire: The Culture of Fire on Earth.** Stephen J. Pyne. 1995; 408 pp. \$19.95. University of Washington Press. **Water and Dreams: An Essay on the Imagination of Matter.** Gaston Bachelard and Edith Farrell, translator. 1942; 213 pp. \$18. The Dallas Institute of Humanities and Culture, 2719 Routh Street, Dallas, TX 75201, 214/981-8810. **Last Oasis: Facing Water Scarcity.** Sandra Postel. 2nd edition, 1997; 239 pp. \$10.95. W. W. Norton. **Dirt: The Ecstatic Skin of the Earth.** William Bryant Logan. 1995; 202 pp. \$12. Berkeley Publishing Group. **The Forgiving Air: Understanding Environmental Change.** Richard C.J. Somerville. 1996; 220 pp. \$13.95. University of California Press. **Global Change: A Review of Climate Change and Ozone Depletion.** Free (quarterly). Pacific Institute, 654 13th Street, Preservation Park, Oakland, CA 20003-1540, 510/251-1600, www.globalchange.org.



THE COMPUTATIONAL METAPHOR

by KEVIN KELLY

Kevin Kelly was editor and publisher of our magazine from 1984 to 1990. He's a daring scout, spotting and reporting back on science and celebrations in a neo-biological civilization infiltrated on every level by technological inventions. He helped found the WELL, the Hackers Conference, and Cyberthon, and is executive editor of *Wired*. See our spring, 1999 issue for his second book, *New Rules for the New Economy*. His first book, *Out of Control: The New Biology of Machines, Social Systems and the Economic World*, can be read at www.well.com/user/kk/OutOfControl/.



The least-noticed trends are usually the most subversive ones. First on my list for an undetected upheaval is our collective journey toward the belief that the universe is a computer.

Already the following views are widespread: thinking is a type of computation, DNA is software, evolution is an algorithmic process. If we keep going we will quietly arrive at the notion that all materials and all processes are actually forms of computation. Our final destination is a view that the atoms of universe are fundamentally intangible bits. As the legendary physicist John Wheeler sums up the idea: "Its are bits."

I first became aware of this increasingly commonly held (but not yet articulated) trend at the first Artificial Life Conference in 1987, where biological reproduction and evolution were described by researchers in wholly computer-science terms. The surprise wasn't that such organic things could be given mathematical notations, because scientists have been doing that for hundreds of years. The surprise was that biological things could be simulated by computers so well. Well enough that such simulations displayed unexpected biological properties themselves. From this work sprung such fashionable patterns as cellular automata, fractals, and genetic algorithms.

The next step in this trend was to jettison the computer matrix and reimagine biological processes simply in terms of computer logic. But to do this, first computation had to be stripped from computers as well. Starting with the pioneering work of Van Neumann and Turing, a number of mathematicians concluded that the essential process of computing was so elementary and powerful that it could be understood to happen in all kinds of systems. Or, in other words, the notion of computation was broadened so wide that almost any process or thing could be described in computational terms. Including galaxies, molecules, mathematics, emotions, rain forests, and genes.

Is this embrace just a trick of language? Yes, but *that* is the unseen revolution. We are compiling a vocabulary and a syntax that is able to

describe in a single language all kinds of phenomenon that have escaped a common language until now. It is a new universal metaphor. It has more juice in it than previous metaphors: Freud's dream state, Darwin's variety, Marx's progress, or the Age of Aquarius. And it has more power than anything else in science at the moment. In fact the computational metaphor may eclipse mathematics as a form of universal notation.

This quickening of the new metaphor was made crystal clear recently in the work of mathematicians and physics who have been dreaming up the next great thing after silicon chips: quantum computers. Quantum computers lie at the convergence of two "impossible" fields, the world of the impossibly small (quantum states), and the world of the impossibly ghostly (bits). Things get strange here very fast, but one thing is strangest of all. In the effort to create mathematical theories of how matter works at levels way below subatomic particles, and in the effort to actually build computers that operate in this realm, some scientists have found that using the language of bits best explains the behavior of matter. Their conclusion: *Its are bits*. Young Einsteins such as mathematician/theoretical physicist David Deutsch are now in the very beginnings of a long process of redescribing all of physics in terms of computer theory. Should they succeed, we would see the material universe and all that it holds as a form of computation.

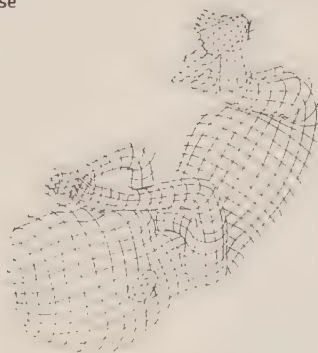

There will be many people who will resist this idea fiercely, for many good reasons. They will point out that the universe isn't really a computer, only that it may act as if it is one. But once the metaphor of computation infiltrates physics and biology deeply, there is no difference between those two statements. It's the metaphor that wins.

And as far as I can tell the computational metaphor is already halfway to winning. ∞

<p>HOPI - ONE WORD (MASA'YAKA) ENGLISH - THREE WORDS</p>	<p>ENGLISH - ONE WORD (SNOW) ESKIMO - THREE WORDS</p>
<p>HOPI - PAHE ENGLISH - ONE WORD (WATER); HOPI - TWO WORDS</p>	<p>HOPI - KEYI</p>

If the top center Beethoven is replaced by a Bach, then the uncertain hexagon receives four doses of Bach for every two of Beethoven.

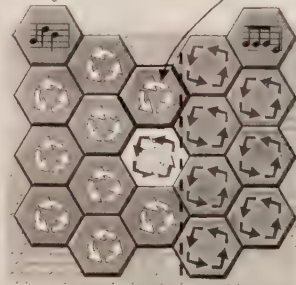

A 4-by-2 boundary ought to be a more stable one than a 3-by-3 arrangement.
FROM THE CEREBRAL CODE

When is a word or synonym or pun a metaphor? Whorf compares Hopi, Eskimo, and English to illustrate words that other cultures would take as metaphors. Bill Calvin tries to reduce musical notes (not words) to "neural gateways" between Bach and Beethoven. DNA is the current metaphor for genetic language. But what about RNA?

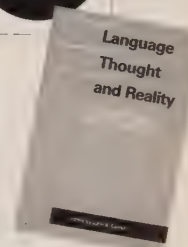
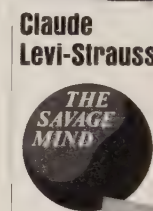
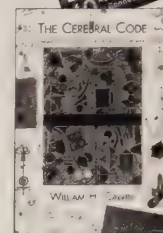
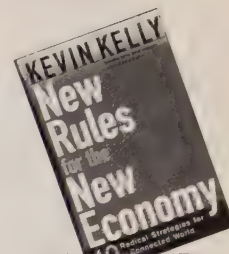

New Rules for the New Economy: 10 Radical Strategies for a Connected World. Kevin Kelly. 1998; 164 pp. \$19.95. Viking. **The Cerebral Code.** William H. Calvin. 1998; 256 pp. \$14. MIT Press. **The Pattern on the Stone.** Daniel Hillis. 1998; 164 pp. \$21. Basic Books. **The Savage Mind.** Claude Lévi-Strauss. 1966; 290 pp. \$16.95. University of Chicago Press. **Language, Thought, and Reality: Selected Writings of Benjamin Lee Whorf.** Benjamin Lee Whorf and John B. Carroll, ed. 1964; 278 pp. \$17.50. MIT Press.



THE POST-MODERN PRETEENS

by WILL BAKER

Will Baker was *Whole Earth's* first reporter at large (in Nicaragua) and then all over the planet, talking to teenagers about their desires and visions of the future. He's an avid dad, scribbler, and farmer of 125 acres of fruit orchards and decorative flowers. Books include: *Backward: An Essay on Indians, Time & Photography* (North Atlantic), *Mountain Blood*, and *Shadow* (both out of print).

What comes out of the mouths of babes is stuff like this:
 "Hey Dad, know what?"
 "Mmm?" (Look up from paper.) "What?"
 "Chicken butt."
 (Fierce snorty giggles, receding.)

Or:
 A-B-C-D-E-F-G
 Wash those cooties off from me.
 Or:
 Hey girls, wanna have some fun?
 Here comes a boy with his pants undone.

There is a lot more, and much worse. Folklore, I suppose, which some people write dissertations about, though a person doesn't require scholarly guidance to get a grip on lines like these. What one needs, to deal with the children of America, is the stomach of a camel and the nerves of a warthog.

I realize I sound cantankerous. Well I *am*. And with good reason. I happen to be living with two children whose combined age is eighteen, members of a neighborhood pack that might all together add up to my own seniority, and the experience has given me a long, dreadful look into the dark heart of our nature, and left me deeply concerned for the dignity of our species.

I won't ruin your dinner by going into too much detail, but must simply remark that between the ears of an average so-called child is a chamber rank as a medieval dungeon, crowded with the imagery of bodily functions and obsessed with plots of mayhem, torture, and perversion. It is permanent Halloween in there; and—an especially ghoulish touch—a lot of the chainsaw and eyeball material is accompanied by rollicking melody or orgiastic chanting. The prepubescent mind also ranks with the Neanderthal when it comes to political incorrectness.

Strong words, I realize, which demand the support of credible examples. I have to warn you the texts below are not suitable for children (who, however, apparently circulated them in the first place). They were obtained firsthand from jump ropers and soccer players, or overheard outside rude hideouts. In the spirit of the Starr Report, I include verbatim transcripts which demonstrate a range of offensiveness.

*Cinderella dressed in yellow
 Went upstairs to kiss a fellow
 Made a mistake
 And kissed a snake.
 How many doctors did it take?
 1—2—3—4—5—etc.*

*Mailman, mailman, do your duty
 Here comes a lady with an African booty.
 She can do the pompoms
 She can do the twist
 But I bet you five dollars
 She can't do this:
 K—I—S—S KISS!*

*The first Old Maid from Canada
 Said mine's as big as the moon;
 A man fell in in January
 And didn't come out 'till June.*

These lines are by no means the worst recorded. I could have skipped to the third Old Maid from Canada, whose exploits make Bill and Monica's cigar caper look like an intermission skit for the Senior Prom at a Bible College. But I wanted to show how even everyday schoolyard lore reveals disturbing overtones. Like the image of kissing a serpent, which suggests both Satanism and obvious Freudian smut, and the allusion to STDs (why else the doctors?). Or the unconcealed racism of the second item, which by the way is flexible enough to include any number of ethnic labels (though rules of scansion have favored those of three syllables: Mexican, Italian, Fijian, etc.), and shows how the quaint cliché of little Caucasian girls made of sugar and spice and everything nice has deteriorated into a vision of rainbow gangs of mini-harlots organizing to out-smooch their rivals.

No surprise that the informants for the first two selections (estimated average age: eight years, seven months) were wearing wrap-around shades and tight bellbottom trousers. They bopped and shimmied during their numbers, tossing their long hair to keep it away from the gum they were aggressively chewing. The unwashed and indescribably coarse rural youths who were caught singing the last entry were also predictable. Like their hero Huck, they have always been in the dirt, literally and figuratively, and will probably stay there for the rest of their lives.

Our children are the future, we always say, but I never realized the dangerous possibilities of

this proposition. Especially now that kids in primary grades are going online, hooking up, so they can pool their awful contraband couplets and ditties, which multiply naturally anyway. (Know why? Cow pie. See a girl, you have to hurl.) A lot of this kiddy trash is no doubt already out there in cyberland. I don't know. I'm afraid to look.

This is my third WE Anniversary chronicle of Young America, and I have, after two decades, arrived at a most unsettling conclusion. We are fundamentally, genetically, an impudent and dirty-minded species. We leave the womb not as poor monkeys (the Bard was never so wrong), but as lusty little apes ambitious to make big messes and revel in them. It won't do any good to appoint a Special Counselor and crack down on playgrounds, or outlaw rap and spray cans. You can just hear the kids responding to that. (*Counselor, Counselor, looks like a nerd / Get too close, he stinks like a turd.*)

About the best we can hope for, citizens, is to minimize the later development of these tendencies. The child (fortunately) diddles in dirt, horror, and anarchy as a game, and maintaining that stance could mitigate adult folly. We might, that is, strive for a state of arrested development. For example, promote jump rope, jacks, marbles, and mumbledy-peg as Olympic sports or at least proper rites for frats and sororities. Or even so simple a thing as requiring rhyme in the *Congressional Record* and on op-ed pages, or making lawyers do crossies and cartwheels whenever they object or petition, or permitting slander and naughty words as long as they are in Pig Latin—whatever could help manage our twisted impulses.

If nothing else there would be a small recreational advantage for observers. Nothing is so depressing, after all, as a cavernous room with no good pictures or toys in it, filled with adults in drab suits who drone on and on, hardly moving, about the same old things: who to drop bombs on when, what ghastly or wrong things other people have done, and how much money to take away from everybody else for the droners to spend. If all these suits jumped rope and did some tag while they droned, they would be much more fun to watch, and maybe they wouldn't think up so many mean things to do to us. ∞

CHILDREN IN AMERICA

- Every 9 seconds: a child drops out of school
- Every 10 seconds: a child is reported abused or neglected.
- Every 15 seconds: a child is arrested.
- Every 25 seconds: a child is born to an unmarried mother
- Every 32 seconds: a child sees his or her parents divorce
- Every 36 seconds: a child is born into poverty
- Every 36 seconds: a child is born to a mother who did not graduate from high school.
- Every minute: a child is born to a teen mother
- Every 2 minutes: a child is born at a low birthweight
- Every 3 minutes: a child is born to a mother who received late or no prenatal care.
- Every 3 minutes: a child is arrested for drug abuse
- Every 4 minutes: a child is arrested for an alcohol-related offense
- Every 5 minutes: a child is arrested for a violent crime
- Every 18 minutes: an infant dies
- Every 23 minutes: a child is wounded by gunfire.
- Every 100 minutes: a child is killed by gunfire
- Every 4 hours: a child commits suicide

FROM THE STATE OF AMERICA'S CHILDREN

Homo Ludens: A Study of the Play Element in Culture. Johan Huizinga. 1986; 220 pp. \$15. Beacon Press. **The State of America's Children: Yearbook 1998.** Children's Defense Fund. 1998; 128 pp. \$16. Beacon Press. **The War Against Parents: What We Can Do for America's Beleaguered Moms and Dads.** Sylvia Ann Hewlett and Cornel West. 1998; 302 pp. \$24. Chapters.

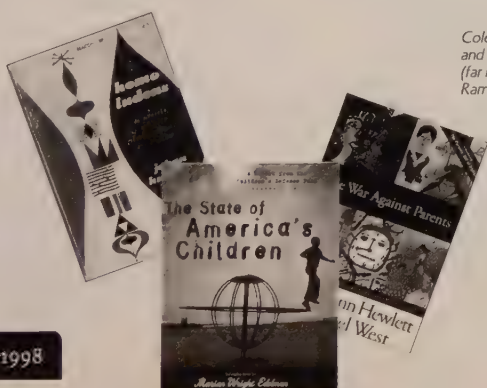

Cole Baker, 10 (far left) and Montana Baker, 8 (far right), with friends Ramona, 9, and Teal, 10.



OUT OF LOVE, NOT FEAR

by DONELLA MEADOWS

Dana Meadows is as fine a friend as Whole Earth could imagine. Brilliant essays pour from her. Every one we print evokes letters of thanks. She's always writing, in between cultivating or canning at the organic farm she shares or teaching students at Dartmouth or organizing the Balaton conferences. Her nine books incisively probe at "growth" (for whom, for what, for how long) and modeling, and offer visions of a compassionate alternative

What's the difference that might most make a difference for a concern close to your heart/mind? How does that difference relate to our teachings to/relationships with young people?

Mind-boggling damn Whole Earth kind of question! My mind tried to find a foothold in it and slipped off into vastness. So, as every teacher does with the real imponderable puzzles, I asked my students—a completely nonrandom sample (seniors, environmental studies majors, Dartmouth College).

I asked them specifically what they had been taught that made a difference, or what they wish they had been taught that would have made a difference. Here are their unexpurgated (except for cleanups of grammar and punctuation and spelling—sigh—seniors!) replies.

“I think one of the best classes I have taken was Nature Writers. We would walk in the woods and write reflections (which we would have to self-evaluate). It was neat because we actually learned life-useful things (e.g. which clouds mean what weather).

“Ishmael (by Daniel Quinn).

“Hmmm...Very interesting writing assignment. I would have to say the most important concept to try to convey to students is the ability to balance the ethical 'value' of human utility (even though I dislike that term—sounds so sterile!) with the utility of future human generations and non-human beings. This conflict is behind almost all environmental debates from wetland degradation to global warming. If we can find some way to relate these two often-opposing sides, we can discuss with less posturing and exaggeration. Money or willingness to pay are not the right measure, but they may help with estimates. The more people we can get thinking about this underlying conflict, the more progress can be made in determining a common language.

“Factors that positively influence my learning are small classes, interactive discussion, and professors who try innovative and interactive methods to expose their students to the subject matter.

As far as what I wish I could learn, that's a pretty tough one. I wish I could learn everything really, but there's not enough time for that, and I'm sure that's not very helpful for you, so I'll try to narrow it some. Here's a short list: environmental issues, specifically policy issues and issues of effectiveness and implementation; natural sciences, stuff about the plants and animals, mostly biology I guess; also lots of random things that aren't necessarily academic pursuits, but things

like I'd like to learn, like how to play the drums, I'd like to learn a martial art, I'd like to learn to be a good photographer, and I'd like to learn a lot more about computer programming and application use.

One of the few committed evangelical Christians I've had at Dartmouth wrote:

“For God so loved the world that He gave his only son, that whosoever believe in him shall not perish, but have eternal life.”

‘Seek ye first the kingdom of God and all these things shall be added unto you.’

Well, that's my 2 cents worth, but you know me well enough that you're probably not surprised. :-)

One student sent back this wonderful (unreferenced) quote:

“Elie Wiesel, speaking of the functionaries of the Nazi regime: They did not come from the underworld; some came from some of the best and most prestigious universities in Germany. They had degrees and even doctorates in medicine, philosophy, jurisprudence, and theology. In other words: they were not shielded by their education. What was wrong with it? It emphasized theories instead of values, concepts rather than human beings, abstractions rather than consciousness, answers instead of questions, ideology and efficiency rather than conscience.

So this is Dana speaking again. I think, wearily, that if we are clearly failing to teach students proper grammar and punctuation and spelling and referencing, we should get a lot more humble about our ability to teach students anything.

And what I tell myself, as I start each course, no matter the ostensible topic of the course, is that there are just three things to teach:

1. The paradigm that there are paradigms, that everything they believe (and everyone else believes) is a biased, filtered, self-reinforcing, close-minded simplification of a Reality far more magnificent than they can ever imagine.
2. That values are real and crucial, not second-rate because they are unquantifiable, not something we'll get to someday when we're done earning money and doing science, not a luxury, but the very point of living.
3. That they should do their best, always, to operate out of love, not fear. ∞



FROM EYE AND BRAIN

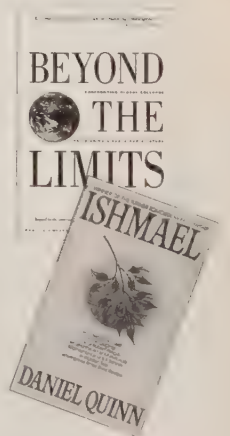

Beyond the Limits. Donella H. Meadows, Dennis A. Meadows, and Jürgen Randers. Reissue edition, 1993: 320 pp. \$16.95. Chelsea Green. **Ishmael.** Daniel Quinn. 1992. 272 pp. \$13.95. Bantam Doubleday Dell.





WRITING ABOUT THE UNIVERSE

by WALTER MOSLEY

Walter Mosley is best known for his Easy Rawlins murder mysteries, which impeccably capture the LA of the fifties and, among other things, the ambiguity between law and authentic justice; between outlaws and right livelihood. *Devil in a Blue Dress* became an exquisite period-piece film with Denzel Washington. His "non-mystery" novel, *RL's Dream*, is one of the best novels ever on New York City and the power of the blues. Walter stopped by Whole Earth on his tour for his first science fiction novel, *Blue Light*. What follows are excerpts (we'll print others in a future issue) from a wonderful, far-ranging conversation on everything from Jimi Hendrix to storytelling to what's important at the root of life itself.

In mystery writing, regionalism goes hand-in-hand with politics. Say you were a union organizer with Chicanos in central California and you wrote a book just about it, let's say a piece of fiction. Only people who were interested in it would read it. But if you created a hyper-conservative Mexican-American detective from Los Angeles who was looking into the murder of the wealthy daughter of some guy who owns one of these plantations and you talked about the unions and the workers and all these people, then everybody would read it. It's a really good way to do that kind of work.

A lot of people are more interested in their own political correctness, or their version of the truth, so it's real hard to do that work. I can write about black Los Angeles and people migrating from the deep South and their relationships, and I do it completely straightforwardly. I have all these people, conservative white people in the Midwest, reading it avidly, thinking they've learned something. And of course whenever you think you've learned something at least you have a chance of maybe learning something.

When you're writing, the idea is to entertain people. If you're a storyteller you sit around telling stories and the thing is that you keep people excited. I was listening to Edwidge Danticat read the other night. She was saying that one of the reasons that she wrote was because the ladies who were gigantic in her life in Port au Prince and Haiti, very small places in the world, would tell stories bridging that gap for the kids. If the kids got tired, all of a sudden there would be a song. Then you'd get back into the story and go on. The idea, of course, is that's how you learn. You keep telling stories that everybody's interested in, that they're elated by, that they find ecstatic in some way, and then they might learn something or they might want to learn something.

I'm into that thing of wanting to learn something. I think that people who really read science fiction are very interested in asking questions about the world and their relationship to the world. Some of those things are ontological, like what is the soul; what is the purpose of life; who am I, sitting in relation to this giant void? There's that kind of stuff. On the other hand, that has relationships to who am I.

I start talking about simple things, like race, in the beginning of *Blue Light*. Here's this guy with a white mother and black father. The black father abandoned him. He thinks like a white person, but he looks like a black person. There's all this other stuff leading to the chapter where the story is saying, what's the difference between you and that tree, and there really isn't much difference. Certainly, we're cousins to the tree, if not more. That's real. That's true. But nobody really thinks it. I'm asking these larger questions and having a lot of fun doing that and making it relate to some smaller issues, but not in a very loud way because you get tired of being put in funny ghettoes about what kind of writer you are—mystery writer, gritty urban dialect writer. I wanted to go someplace else.

I was writing a piece about why black people don't write in genres. The title of the thing is, "Why Aren't There More Black Science Fiction Writers?" There are just five that I know of. But all black people read science fiction. It's almost political. They say, I can't stand this world, so where's another world that's not completely massaged by Robert Kaplan [*Ends of the Earth*] or whatever? You can read Barrington J. Bayley or Brian Aldiss or Tolkien. I believe that there's a white literary establishment that might be liberal (which doesn't mean much). That establishment sees black writing as kind of a footnote—they would never say it—but really as a footnote. The footnote specifically is addressing the nature of your chains, the suffering of black people in America. This is not a bad thing. I'm not attacking it necessarily. You have James Baldwin. You have Richard Wright. You have Zora Neale Hurston. You have a lot of people. But the problem with it, if you look at it closely enough, is that if

you're only examining the nature of your chains it really means you're only examining your relationships to white America and to white people in America. If you're saying, I'm chained, and I'm attached to this person who's chaining me, it seems like they're not chained. Or if they're chained, they're only chained to you. This is not true. They're also chained. Writing something like *Blue Light* is getting away from that. I'm going to write about the universe. The universe? What does that have to do with slavery? It doesn't have anything to do with slavery. What does that have to do with racism? It doesn't have anything to do with racism.

It's like Spider Man or Captain America—anything that can empower and deny finds purchase in the black community. It's important to do that. It's important to say, I'm not paying attention to those chains because as long as you're paying attention to those chains you can't pay attention, for instance, to Africa. Africa is impossible. Africa is an impossible place for what has developed as black consciousness in America. We have developed on a European model and the European model is steeped in racism, even though now it pretends that it isn't. Just to speak the language is to be racist.

I was in Paris two years ago being interviewed by a woman who was saying the racism in America was so terrible and, you know, I'm agreeing with her. And then at one point she says, well, you know, we don't have that here. I said, have you talked to the Arabs in Paris lately? They seem to think that you hate them. She ended the interview. She said, I have enough now. They see their racism as just making sense.

I love Albert Camus. I love *The Stranger* and "The Myth of Sisyphus." "Sisyphus" is like that one-tenth of one percent of life that is truly ecstatic. The other ninety-nine percent is capitalism. I adore Langston Hughes because he loved being black—a writer writing from the place where you love being who you are. I love James Baldwin and Richard Wright, but there's a lot of conflict in there because that self-hatred is so deep. Camus's writing and his life blended. I was often asked to speak for Rushdie or read for Rushdie. I was asked by PEN, an organization which I basically quit. I said I'd be happy to do it but in the first half of the ceremony we have to say that we apologize to Iran for three decades of war that America has made on them. We have to apologize for the Shah. We have to apologize for the torture. We have to apologize for the CIA training their police force. We have to apologize for the billions of dollars we gave Saddam Hussein in order to attack and destroy hundreds of thousands, if not millions, of Iranian lives. They said, no, we can't do that because we're writers. But Camus, it was part of his nature, and the anarchists of the early part of the century, it was part of their nature, to say: I have to do what's right. I can't do what's wrong. If the Arab side of the conflict does something wrong, I have to attack them. If the French side of the conflict does something wrong, I have to attack them. What's right has to be right for both sides. It's very rare that you find that in today's political thinking. It's not articulated. It's a hard thing. It burns you up.

You can talk to somebody and they ask, how can I make a difference in my life? Well, just read a book every week. They say, yeah, what will that do? I say, I'm not really sure, but it will make a difference. If you read a book one day and another day talk to somebody about that book it will make all the difference in the world. Or write or draw. I've been drawing bad pictures for thirty years. I think that's really good. I think it's wonderful to draw bad pictures and to write bad poetry, or maybe write great poetry, but that's not the issue.

It's like the idea of meditating. You're never going to reach enlightenment, but at least you're gesturing towards it. You're trying to reach enlightenment and that's a kind of perfectionist thing, but at least it's personal. It's not like how much better my enlightenment is than your enlightenment. ∞



RL's Dream. Walter Mosley. 1995; pp. \$12. Washington Square Press. *Blue Light*. Walter Mosley. 1998; 296 pp. \$24. Little, Brown and Company. *The Stranger*. Albert Camus. Reissue edition, 1989; 123 pp. \$9. Vintage Books.

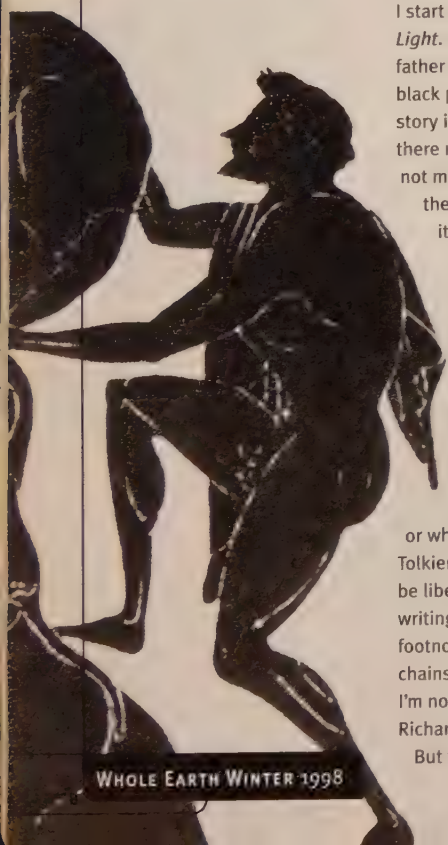

MILEPOSTS

by MARY CATHERINE BATESON

Mary Catherine Bateson is hugely multidimensional—linguistics, the Middle East, anthropology—with books on AIDS, the sacred, her parents (Margaret Mead and Gregory Bateson), learning, and thinking about life changes (her popular book *Composing a Life*). She's on sabbatical from George Mason University, recovering from the fabulous wedding of her daughter, and, with typically exceptional competence, pulling together the Margaret Mead Centennial (p. 33).

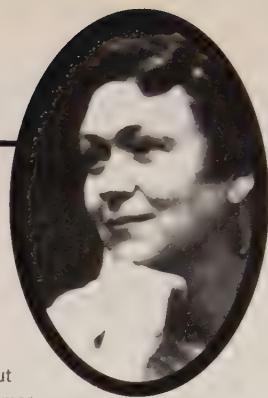

So... you're having another birthday, Whole Earth. You're going the easy way, celebrating when there is a five or a zero in your age, which is traditional but arbitrary. For human beings, if not for magazines, we need some new ways of thinking about development and aging that take account of the new demography, for the mileposts of the past have changed their meanings.

For example, I've been wondering whether we should shift over to the duodecimal system in thinking about age, finding a way to fold new longevity into familiar figures. For anyone who remembers calculating on the base twelve instead of ten in school, you'll know that by adding two new digits to the system for 10 and 11, you get to say you are 10 (DD—for duodecimal) when you have lived 12 years (decimal), which is now a pretty good approximation for puberty (which used to come later and lacked a zero). Twenty (DD) corresponds to 24, 30 (DD) to 36, and so on. This should please everyone but the twelve year olds. In fact, the rhythm of the life cycle has changed so dramatically that the other zeros also fall meaningfully in the DD system: 24 (DD 20) is the earliest most people can hope for a regular job—economic maturity—and 36 is a better moment than 30 to mourn youth's passing and the ticking of the biological clock.

Work it through the duodecades. People used to hope (not, mind you, expect) to survive until age 70 (that was the Biblical three score and ten), but today 70 seems young and lots of 70-year-olds are getting married or traveling the world. DD 70, however, would refer to 84, and DD 100th birthdays would fall back to decent rarity, representing a genuinely remarkable 120 years of life in the decimal system.

Fun to think about, but of course it's not going to happen because of the technological lock—we prefer to let a system of meaning become obsolete rather than revising our technology. But it's worth considering that the year 2000, because it requires so much new programming, might be the last chance in human history to rethink the way we count and maybe to divorce our counting of history from a Christian system that is only meaningful for a fraction of humanity.

Another way to go is to ignore the numbers and notice instead that new developmental landmarks have appeared in the human life cycle and old landmarks acquire a new meaning when they occur at a different

moment. Becoming sexually active is probably less momentous than it was, but it's much harder to make the decision of marriage than it used to be and it is happening later. Traditional ceremonies are back in fashion, perhaps because of the need to mark the new transition ritually.

Having a first child is far more earth-shaking for both men and women when it happens later, when it is a fulfillment of long hope and waiting rather than something that follows automatically from sexual activity or marriage. People who have been adults for quite a while without children have to revise their whole sense of what adulthood means (by the way, DD 21 would refer to what we call age 25). Even those who are starting second families encounter a totally new kind of experience with childbearing, especially men present at delivery for the first time.

Then there is the realization of mortality. Most human beings in past centuries became aware of their own mortality in childhood through the deaths of siblings. The point was driven home when parents died—the experience of losing a parent to death during childhood can be compared to the experience of parental divorce today. Psychologists used to speak of adolescent grandiosity including the sense of immunity to danger, but that illusion may be creeping upward because it is possible for so many people to defer facing the reality of death. At the same time, two other landmarks that used to come earlier now offer new meanings: potentially mortal illness and the death of parents. A first heart attack or cancer or seroconversion, when these dark woods are encountered after 40 or 50 years of health, provokes, at least for some people, moments of assessment, moments to reconsider their values and decide what they really care about. The death of both parents signals to many, I'm next, I'd better decide who I am while there is still time. Whole Earth has had a couple of brushes with death, which, it is to be hoped, have occasioned some serious thought about reasons to stay alive.

And then there are the fresh starts. Silver-haired new graduates, wrinkled but glowing lovers. Above all, the ability to think of a transition like menopause as the beginning of a new era of energy and freedom. May we use our added years and fresh starts creatively, for creativity is surely needed.

Happy birthday, Whole Earth. Many happy returns. ∞

Rites of Passage: A Post-modern Guemica
by Arthur Okamura
Arthur Okamura drew *CoEvolution Quarterly's* first cover and the revival *Whole Earth's* first cover. Artist in many media, dining room table trickster, and generous friend of *Whole Earth*

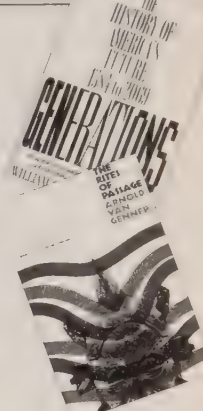
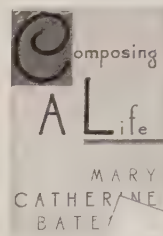
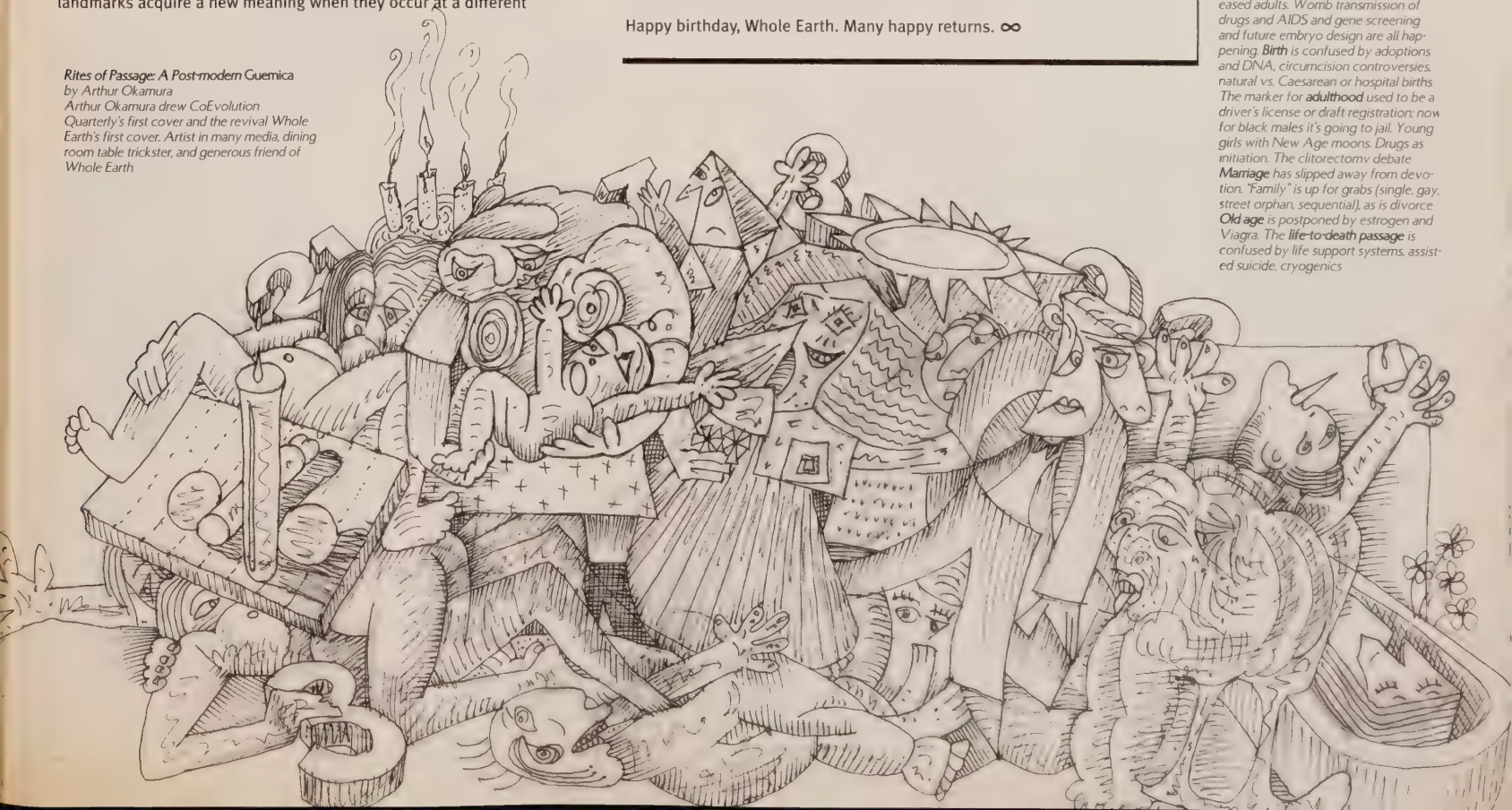

Composing a Life. Mary Catherine Bateson. Reissue edition, 1990; 241 pp. \$12.95. Plume. *Generations: The History of America's Future, 1584 to 2069*. William Strauss and Neil Howe. Reissue edition, 1992; 538 pp. \$14. William Morrow. *The Rites of Passage*. Arnold Van Gennep. 1961; 198 pp. \$9.95. University of Chicago Press.

Rites of passage have lost their boundaries and been infiltrated by technology. *Conception* occurs in test tubes or surrogate wombs or is blocked by pills, subcutaneous fertility controls, condoms, etc. Abortions are common, and fetal tissue may live on to save diseased adults. *Womb transmission* of drugs and AIDS and gene screening and future embryo design are all happening. *Birth* is confused by adoptions and DNA, circumcision controversies, natural vs. Caesarean or hospital births. The marker for *adulthood* used to be a driver's license or draft registration; now for black males it's going to jail. Young girls with New Age moons. Drugs as initiation. The clitorctomy debate. *Marriage* has slipped away from devotion. "Family" is up for grabs (single, gay, street orphan, sequential), as is divorce. *Old age* is postponed by estrogen and Viagra. The *life-to-death passage* is confused by life support systems, assisted suicide, cryogenics.

RED PUMPS AND STYROFOAM GENDERS

by PATRIZIA DILUCCHIO

Patrizia DiLucchio, a former nurse, health policy analyst, model, criminologist, and topless dancer, broke into print with the cover article on birthtales in WER No. 78. She writes regularly for *Entertainment Weekly* and *Women's Wire*, while continuing to grace our pages with her candor and wit. She copped the prize Millennium Whole Earth Catalog gig, editing—with flair—the Sex, Death, and Women's Health sections. She lives in Monterey with her husband, two kids, two dogs, and one snake.



Frankly, I don't spent a lot of time thinking about gender roles. Call it a luxury associated with living in the family of nations that makes up the West—there are no wild-eyed clerics forcing me behind a veil here in California, though our own homegrown fanatics, springing principally from conservative flavors of Christianity, still daydream of a home where only Mr. XX wears the 501s—but in practical terms the days when women's gender roles in my part of the world were carved in marble are long gone. Today's rules are etched in Styrofoam.

What are gender roles anyway, as we slouch ever closer to the new millennium? Those same zealots who talk about veils and pants are convinced that their own ideological views reflect some eternal nexus of theological purpose and biological design. Women bear and raise children. Men hunt mammoths. A few of the less religiously inclined voices advocate limitations on the role of women in society under the broad and confusing umbrella of "family values." The real role of gender in the modern age, and please, let's not confuse gender roles with sexuality, has always been more about economics and the de facto link between marketplace power and political clout than it has been about comparative anatomy. Follow the money. Just as there have always been economic and political arguments hidden behind the platforms of racism or anti-Semitism, so too money and power enter into the equation regarding gender bias. The same gains seen in the suburbs are harder to find in the inner city where poverty is the norm. In the years of lock-'em-up law and order since the eighties, rates of incarceration for men have more than doubled, but for women the increase has been five-fold.

American women entered the work force in significant numbers in the 1920s—actually women were always a vital part of the work force if we consider agriculture—but the Great Depression negated those gains. Women came bouncing back during the war years in the early 1940s, whether as truck drivers, or airplane mechanics, or steelworkers—only to lose those jobs when the "boys" came home. Somehow it seemed patriotic to fire a woman and hire a man to do her job. Besides, the baby boom that followed created the largest pool of new consumers ever seen in the US, and somebody had to change all those diapers while the menfolk were earning the down payments for tract homes. It comes as no great surprise that women jumped right back into the work force once the boomers were out of the house. What they never mentioned on *Leave It To Beaver* was that June Cleaver probably had a realtor's license. Looking at the past eighty years, it's pretty easy to see that gender barriers didn't topple like the Berlin Wall with the birth of feminism. They've been crumbling for generations, fueled more by the great maw of consumerism than by the wishful thinking of any particular social agenda.

We got the vote and went to work. But how many families can afford to buy a house on a single income? How about the sport utility vehicle, braces for the kids, and that dish television system?

Once women entered the workplace for good in the sixties and seventies it followed that soon no single corner of the workplace would remain off-limits. The arguments against a woman as a firefighter, or a police officer, or a CEO ultimately rang as hollow as those earlier arguments against a woman in any other position. Even the military's aversion to women in combat positions was severely compromised in the Gulf War when women pilots were placed in the line of fire. Certainly there are still glass ceilings in the corporate workplace, gender bias remains epidemic outside the developed economies of the West, and even within those areas of Western economies dependent upon so-called 'cheap labor,' as well as in some blue collar trades where men continue to exercise at least a casual prejudice, but by and large for Ms. XY, gender has simply ceased to be a factor in legitimate career counseling.

This is a good thing. Maybe.

As a society while we've come to embrace our sisters' moves into the marketplace, we continue to frown upon anything that smacks of our brothers' moves away from that grindstone. The soccer mom holds down a job, drives a minivan, does childcare, and continues to do eighty-five percent of the cooking in most homes. Dad's stuck in his cubicle for sixty hours a week and if he even thinks about flex-time or job sharing he can kiss promotion good-bye. True, there are role reversals in some households—dad drives the minivan, cooks, attends soccer games, contributes to the cash flow in some fashion, and it's mom who's stuck at the office, but ultimately the message is the same. We're all working way too hard. Will that change in the next millennium?

Not likely.

Gender equality comes at a price. The lesson of the level playing field is that everyone has to compromise. And, needless to say, compromise is never ideal. We'll elect a woman as President, but we won't elect a single mom, let alone a housewife. And we may figure out a way for our husbands to bear children, but will they ever look good in red pumps? ∞



FROM GENDER ADVERTISEMENTS



Beyond the Veil: Male-Female Dynamics in Modern Muslim Society. Fatima Mernissi. 2nd edition, 1987; 200 pp. \$12.95. Indiana University Press. **Hard-hatted Women: Life on the Job.** Molly Martin, ed. 1988; 272 pp. \$14.95. Seal Press, 3131 Western Avenue #410, Seattle, WA 98121, 206/283-7844. www.sealpress.com. **The New Joy of Sex: A Gourmet Guide to Lovemaking for the Nineties.** Alex Comfort, M.D., D.S.C. 4th edition, 1994; 253 pp. \$20. Simon & Schuster. **The New Good Vibrations Guide to Sex: Tips and Techniques from America's Favorite Sex Toy Store.** Cathy Winks and Anne Semans. 2nd edition, 1997; 304 pp. \$21.95. Cleis Press, PO Box 14684, San Francisco, CA 94114, 415/575-4700.

INTEGRATIVE MEDICINE

by ANDREW WEIL, MD

Andrew Weil, MD is on our editorial board. He brings his encyclopedic knowledge of all kinds of healing, his (now amazingly successful) ambassadorial acumen to bridging Western medicine to other traditions; a humane perspective on altered states of consciousness; a love of fireworks and mushrooms; and excellence in popular writing. His first book, *The Natural Mind* (1971), is still stunning. He's written five more. He is currently Associate Director of the Division of Social Perspectives in Medicine and Director of the Program in Integrative Medicine at the University of Arizona. He graciously found time in his incredibly busy schedule for this phone interview.

The speed with which medical institutions, including medical schools, are beginning to open to integrative medicine is astonishing and very gratifying. They're being forced into it. The institutions have no choice but to adapt; nonetheless it's nice to see. This change in medicine could be very important to society, going way beyond developments like alternative therapies. To give one example: if physicians were educated about the relationship between the environment and health, and really came to appreciate environmental causes of illness, they could as a group be a very powerful force pushing for environmental

protection and clean-up. A more conscious, more enlightened medical profession would be a strong agent for social changes within our culture.

Breast cancer and neurological diseases such as Parkinson's and ALS, for example, are going to turn out to be traceable to environmental toxins like endocrine disruptors. Doctors' educations now include none of this understanding of environmental toxins as a causation of disease. Physicians as a profession have been very apathetic and just haven't pushed for this, though they're the ones who should be

most concerned about it.

It's how physicians are trained and also our culture's very reductionist thinking. It's the prejudice and bias of science in our culture to see natural products as inexact and want to reduce activity down to single compounds. Medical education really isolates people from nature. Students have no first-hand experience of it in their training and pick up the prejudice that nature is inexact and wild and uncontrolled and dangerous.



GRIEF

by STEPHANIE MILLS

Stephanie Mills has been a Whole Earth reviewer since 1972. She was assistant editor and editor of CoEvolution Quarterly, co-edited the special bio-geological issue in 1981, and edited the Communities section of the Millennium Whole Earth Catalog. She edited *Turning Away from Technology*, which includes her own lovely essay on the monkey trap of technology—the embarrassing contradiction of enjoying its comforts while bemoaning the totality of its effects. Her other books include *In Service of the Wild: Restoring and Re-inhabiting Damaged Land* (Beacon) and *In Praise of Nature* (Island Press). She now lives and writes in Maple City, Michigan, where the temperate broadleaf forests mix with the sub-polar, all modified by the Great Lakes and us



As I recall, Stewart Brand had the thought that became the Whole Earth Catalog while looking out the airplane window on the trip home from his father's funeral. Only now, having fairly recently flown home from my mother's memorial service, am I beginning to understand the momentousness of a parent's death. I can only admire Stewart all the more for having acted upon that moment and transmuted his grief into a creation as rich and significant as the Catalog. If the death of a man's father happens to give rise to the altruistic experiment of providing access to tools for those who would get good at being gods, what idea might arise in the mind of a woman who has just been initiated into the communion of motherless children?

The answer is not an idea, but some inchoate liberation within, whose elements are surrender and resignation. Death is huge, baffling. Although I saw and touched my mother's cool, still body at the mortuary and watched her coffin enter the crematorium, I cannot comprehend what has happened. With my mother died the body that made me here on Earth and any existential claim to mammal nurture I might have. Now comes the task of fostering the wisdom born of sorrow. It would be good to have some conceptual news or a brilliant vision, but all I've got is my longtime mix of melancholy and a pinch of hope.

The melancholy is engendered by all that looks unstoppable. After, say, 10,000 years of human history, it seems to me that we have less of everything that we started out with except human beings and their increasingly similar artifacts. Maybe this was all meant to be, the price (tendered mostly by first peoples, other species, earlier times) to be paid for our species to wise up and design for living on this particular planet. We have reduced the ecosphere through sheer inadvertence and now must find ways to live with what we've done. There's that relentless memory hole that devours any sense that there were ever other kinds and ways of life than what we know now.

Personally, I haven't much zeal for the adventure of forward change. Yet I am so grateful that there are individuals and groups who see things whole and real, who don't repine and do invent.

Intelligence—embodied, applied, undomesticated intelligence—mind in nature and keeping nature in mind—is ever what makes the difference. Aesthetic values—as in sailboat, fibula, talon austerity, squash tendril, bird wing, knife blade elegance—afford a discipline that can set us on the beauty way. Applying some rigor in penetrating the desiderata of “place,” “community,” and “sustainability”—to their hard cores—might make a difference.

How we come to a knowing acceptance of the conditions we'll confront in the not-so-distant future, how we do our suffering once these globalizing, simplifying, homogenizing processes have climaxed, how we do our grieving for the wastage of our Mother Earth; those inward and cultural processes, those anvils of truth, could forge the difference in us.

I didn't invoke the fact of my mother's death to serve as a metaphor, or to parlay my personal grief into an elegy on the demise of the biosphere. I just wanted to explain the nullity of my imagination and why news seems less important than memory just now, and difference less salient than continuity. Life and death and time are still the daemons of difference on planet Earth. As my neighbor Peggy says to perspectify her worries, “In a hundred years, all new people!” Plus post-Cenozoic ecosystems, watershed cultures, unprecedented circumstances, redefined optima, and other grounds for hope.

Till then, says Sterling Bunnell (in *Gnosis* No. 33): “Don't panic. Try to appreciate your own lives, and try to help a little loveliness to continue.” ∞

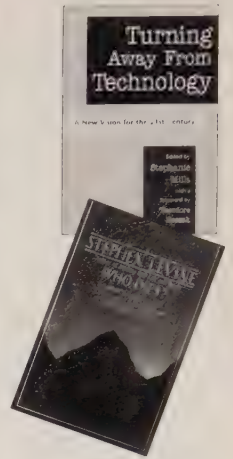

Turning Away from Technology. Stephanie Mills. 1997; 256 pp. \$18. Sierra Club Books. **Who Dies? An Investigation of Conscious Living and Conscious Dying.** Stephen Levine. Reissue edition, 1989; 317 pp. \$11.95. Anchor. **The Harvard Guide to Women's Health.** Karen J. Carlson, Stephanie A. Eisenstat, and Terra Ziporyn. 1996; 718 pp. \$24.95. Harvard University Press. **Spontaneous Healing.** Andrew Weil. Reprint edition, 1996; 309 pp. \$12.95. Ballantine Books. **The Essential Book of Traditional Chinese Medicine.** Volumes 1 and 2. Liu Yan-chi. 1987; 305 and 479 pp. \$19.50 each. Columbia University Press.

BOTH IMAGES FROM THE ESSENTIAL BOOK OF CHINESE MEDICINE

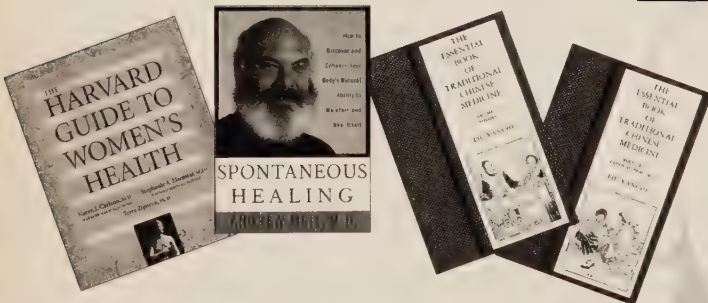

Other interactions of environment and health include evolution of new diseases, especially new bacterial strains, and other factors contributing to the weakening of human immunity and defenses. We'll have to see what happens with these new diseases, but there is reason to be worried. Integrative medicine looks at antibiotics, for instance, in several ways. First, it doesn't reject antibiotics totally, but tries to teach people when it's appropriate to use them. Second, it tries to strengthen the body's defenses rather than just attack the germs; that approach especially comes from Chinese medicine.

A few years ago, I was with a Japanese scientist whose field of research was herbal medicine. He had just done a speaking tour of the US and was struck by how closed to this information the American scientific and medical

establishments are, in contrast with those in other countries. The interface of environment and health and the medical profession's role in understanding the larger ramifications of medicinal plants, horticulture, and species protection is a huge issue. Certain medicinal plants, for instance, will actually become endangered because of recent demand. Wild echinacea is one that's probably in danger. Goldenseal is already endangered. That's something that the New Age never expected to be the result of success.

Nevertheless, we must not abandon the diagnostic rigor of modern medicine. At least at this point, for instance, diseases affecting “environmentally sensitive” people are problematical. There are practitioners and clinics that are making their living off of such people.

There's definitely not agreement within scientific medicine about what this is. It's unclear to me that it is a really definable condition or how much of it is psychological. It's unknown. But it does seem as if there is an increase of illness of all sorts that may have roots in environmental toxicity.

I tell prospective doctors to get out and educate themselves about important things before they start formal training, and to exploit any free time during their training to gain other perspectives and learn things that they're not getting in their standard education. I don't think that a curriculum exists for students to learn to integrate all aspects of the environment with medicine. It's time to create one. ∞

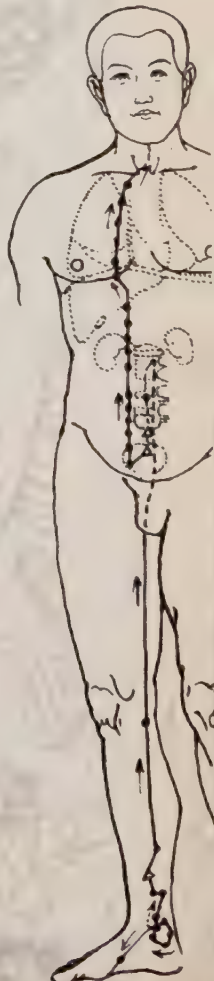

PLANT TEACHERS & THE PATH OF EVE

by DALE PENDELL

Dale Pendell is Whole Earth's contributing editor on plant powers, an immense job if you think of it. In addition to being an ethnobotanist writ large, he's an elegant craftsman of poetic prose and a software engineer. This short essay is from his upcoming book *Pharmako/Gnosis: Plant Teachers and the Poison Path*. Dale told me he writes for us because we cherish adventurous intellect, trust his imagination, and refuse to edit out or water down his ideas. What a gracious compliment.



Plants were the first of Earth's creatures to establish extraterrestrial contact. First Contact. Beyond the sulfur vents and the acid radicals deep in bedrock, the seafloor ruptures. The first to contact the greater cosmos.

Intelligence collectors, electron transfer chains up an entropic pathway, latent complexities of space, a shamanic balancing act at 1 AU.

Every carbon atom in our bodies has at one time passed through the chloroplast membrane of a plant.

Plants are the placenta of all animal life, from when the humans (homunculus, humus, hence "earthlings") were a mere wisp of dream in a chancy future.

Love and strife, Empedocles maintained. The sieve of selection and the fandango. Fit survival, but also the peacock's tail, exuberance, excess. A great swirling, and a song arose. Katydid, cicadas. Munching on green. Autophagia really. Or eating the god.

And the gods fought back: alkaloids, CNS poisons, tryptamines, beta-carbolines, lianas snaking from the canopy. Fungi garnered the recycling trade. Partnerships, parasites, nothing standing still.

Oils, terpenes, carbohydrates, even protein, the main course of the teachings. And beyond, like a graduate school, "secondary metabolites," the poisons, the medicine.

Ye shall not eat of it, neither shall ye touch it, lest ye die.
(Genesis)

The Original Prohibition, our first drug law.

To plant people everywhere, certain plants are regarded with a special reverence: the sacred plants, sharing something of godly nature. That which had been attacked, that which resisted, the rebels, "thus far and no further shalt thou come."

Plants represent immediacy, a seamless suchness. No comments. No philosophizing, no rationalizing. Just the Fact. The Buddha once preached a whole sermon by holding aloft a flower. Kasyapa understood and smiled.

We can find the songs in ethnopoetics, or hear the prayers from those who have maintained the archaic connection, but it's all in Milton:

*O Sacred, Wise, and Wisdom-giving Plant,
Mother of Science, Now I feel thy Power
Within me clear, not only to discern
Things in thir Causes, but to trace the ways
Of highest Agents, deem'd however wise.*

There was a great taming, leaching the tannins or cooking out the cyanide: acorns, cassava, breeding the tame ones. Women's work. Root gatherers and kitchen chemists. A few of the god-plants entered the *chagra*, the circle, like barbarian nomads finding a fertile valley, but mostly they stayed wild, became a specialty of those daring to eat wildness, the bitter. Plants with a voice: the Tree of Knowledge.

On a large bronze door cast around 1020 in the cathedral in Hildesheim, the Tree has a vague mushroom shape. It may be modeled after local

daisies, small nub of disk flowers, the ray petals drooping, or perhaps a deadly Lepiota, *L. castanea*, or, some say, *Psilocybe semilanceata*. In a fresco on the ceiling of the Romanesque church in St. Savin in central France, the Tree resembles *Amanita muscaria* with tiny fruit hanging from the cap. This is perhaps a Byzantine stylization of a date palm. Or is it?

*O Sovran, virtuous, precious of all Trees
In Paradise, of operation blest
To Sapience, hitherto obscur'd, infam'd,
And thy fair Fruit let hang, as to no end
Created; but henceforth my early care,
Not without Song, each Morning, and due praise
Shall tend thee, and the fertile burden ease
Of thy full branches offer'd free to all;
Till dieted by thee I grow mature
In knowledge, as the Gods who all things know.*

Eve has many depictions, sometimes thin, sometimes fleshy or nubile, sometimes like Isis. On the north portico of the Gothic cathedral at Rheims, she cradles a small reptilian creature in her arms, tenderly. Blake made her voluptuous. From a distance, his painting of Eve accepting the apple from the mouth of the serpent looks like an act of fellatio, Eve's hand caressing the serpent's head. At Notre Dame it's a threesome, our loving Forebears joining their hands together around the Serpent's arboreal phallus. Eve's way, the one who dared. The one who shared. The patron saint of the poison path.

*Shall I to him make known
As yet my change, and give him to partake
Full happiness with mee, or rather not,
But keep the odds of
Knowledge in my power
Without Copartner?*

Eve is also Pandora, the gifted and the all-giving. Poisoned gift, all the sorrows of life on the great wheel of becoming. German *gift*, poison, related to Anglo-Saxon words for espousal, the bride-price. Something must be given. Something must be let go. Poison and medicine are samsara and nirvana, forever wedded.

In an African version of the Pandora story, what was left at the bottom of the casket was a gourd of beer, that given by the gods. Enthusiasm is ebriety. God within.

As with new wine intoxicated both They swim in mirth, and fancy that they feel Divinity within them breeding wings. A playfulness in the sacrament: within the poison, a gift. Thus, dialectic. The truth, as glimpsed by Hegel, "is thus the bacchanalian revel, where not a member is sober." A fugitive quality, a beyondness. Atalanta fleeing, the Great Matter, ultimate seriousness, but it never quite stops dancing. We can point to it, we can present it, but in the end it refuses definition. And we are grateful.

*So saying, from the Tree her step she
turn'd,
But first low Reverence done, as to the
power
That dwelt within, whose presence had
infus'd
Into the plant sciantial sap, deriv'd
From Nectar, drink of Gods.
—Milton, Paradise Lost ∞*



PHARMAKO / POEIA



Pharmako/Poeia: Plant Powers, Poisons, and Herbcraft Dale Pendell. 1995; 287 pp. \$19.95. Mercury House, 736 Clementina Street, Suite 300, San Francisco, CA 94103. 415/626-7874. www.wenet.net/~mercury. HempWorld: The International Hemp Journal \$15/year (quarterly) 8080 Mirabel Avenue, Forestville, CA 95436. 707/887-7508. www.hempworld.com. Medicines from the Earth: A Guide to Healing Plants William A. R. Thomson, M.D. Out of print. Plants of the Gods: Their Sacred, Healing and Hallucinogenic Powers Richard Evans Schultes and Albert Hoffman. 1992; 192 pp. \$22.95. Healing Arts Press, One Park Street, Rochester, VT 05767. 802/767-3374. www.innertaditions.com. The Secret Life of Plants Peter Tompkins and Christopher Bird. 1989; 402 pp. \$17. HarperCollins.

MAZATEC SHAMAN FROM PLANTS OF THE GODS



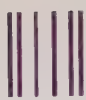

NO POSTAGE
NECESSARY IF
MAILED IN THE
UNITED STATES

BUSINESS REPLY MAIL
First Class Mail, Permit No. 292, Denville, NJ

POSTAGE WILL BE PAID BY ADDRESSEE

Whole Earth

P.O. BOX 3000
DENVER, NJ 07834-9879



NO POSTAGE
NECESSARY IF
MAILED IN THE
UNITED STATES

BUSINESS REPLY MAIL
First Class Mail, Permit No. 292, Denville, NJ

POSTAGE WILL BE PAID BY ADDRESSEE

Whole Earth

P.O. BOX 3000
DENVER, NJ 07834-9879



SAVE 25% OFF THE COVER PRICE!

GET WHOLE EARTH FOR ONE YEAR (4 ISSUES) FOR ONLY \$22

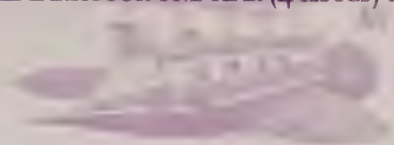

Name

Address

City/State/Zip

Bill Me Later

Payment enclosed

Canada: US \$25 includes postage and GST. All other foreign countries: US \$30. Please allow 6 to 10 weeks for first issue.
For new orders only. 309551

SAVE 25% OFF THE COVER PRICE!

GET WHOLE EARTH FOR ONE YEAR (4 ISSUES) FOR ONLY \$22

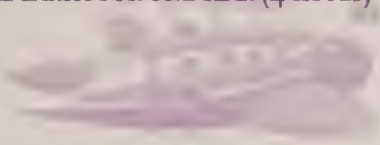

Name

Address

City/State/Zip

Bill Me Later

Payment enclosed

Canada: US \$25 includes postage and GST. All other foreign countries: US \$30. Please allow 6 to 10 weeks for first issue.
For new orders only. 309551

STAY ON TOP OF
THE WORLD.



subscribe

HOW TO

WHOLE EARTH

AND

save
25%

OFF THE COVER PRICE

800-783-4903

NATURAL SYSTEMS AGRICULTURE

by WES JACKSON

Wes Jackson is a farmer/scholar of the Jeffersonian ilk. He tries totally original stuff, such as growing a mix of perennial native plants (polyculture) to see if they can produce food value equivalent to agribusiness crops and still remain a part of the local ecosystem. He's been a friend of *Whole Earth* for decades (recently he joined the editorial board). He runs the Land Institute (2440 East Water Well Road, Salina, KS 67401; 785/823-5376), which is a great place for graduate-level students to get a hands-on education in non-harmful agronomy. *Becoming Native to this Place* and *Altars of Unhewn Stone* (WE 91) are recent works

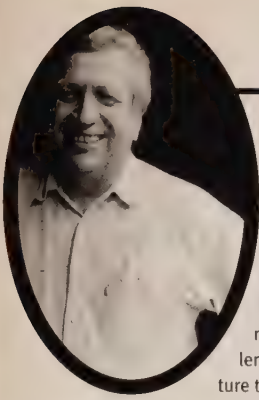

We now have a chance to seriously work toward solving the problem of agriculture, rather than constantly trying to solve problems in agriculture. It's feasible now for agriculture to be based on the way Nature's ecosystems have worked over millions of years rather than on

Nature being subdued or ignored. Natural Systems Agriculture is going to require about twenty-five years and in the neighborhood of \$100-150 million spread over that twenty-five-year period: peanuts, really. Soil erosion, according to Dave Pimentel at Cornell, costs over \$44 billion per year. I think we're at an exact instant in history in which the evolutionary ecological paradigm with its modern molecular synthesis is going to stand over and against the human cleverness approach promoted by the Monsantos of the world. It's not that I'm totally against all kinds of gene-splicing or biotechnology, but they ought to be in a subordinate role.

I'm hopeful that we can convince an increasing number of smart scientists and others to get cracking on this. We're also going to need the people out of the humanities and the social sciences to help keep Natural Systems Agriculture on track. When the radical nature of what we're talking about becomes apparent, it's going to require support from a broad spectrum of people. The Monsantos, the pharmaceutical houses, and the seed houses that now own so much won't be happy. We're going to need people who will protect Natural Systems Agriculture so that the rewards run to the farmer and the landscape. If that doesn't happen, farmers are increasingly going to be part of a feudal system, a proletariat that is effectively serving the owners of the land and the input. What's on the line is nothing less than whether we're going to remain relatively free or whether we're going to keep feeding the oligarchy. So, it's radical from several points of view: Nature's not to be subdued or ignored but looked to; rewards go to the farmer and the landscape rather than to the suppliers of input who are laundering the subsidies (or, more precisely, to the suppliers for whom the farmers are laundering the subsidies). Natural Systems Agriculture is, then, a direct challenge to the Baconian-Cartesian world view in favor of an evolutionary, ecological view.

The industrial hero says we must feed the world. The evolutionary ecological agriculturist, on the other hand, says the world must be fed. The latter recognizes important nuanced differences: the reality of the ecological mosaic and a kind of agriculture interested in local adaptation.

On the one hand, a common philosophy of bioregional specialization unites so-called Third World people with people in industrialized society. Respecting evolution in natural selection—different bioregions favor different plants—also gives respect to a mosaic of agricultures. That's the unifying principle.

On the other hand, the industrial approach of those who have the oil and the natural gas—the industrial input—is essentially to parachute technologies

into Third World economies and set up brittle infrastructures. So solving the problem, it seems to me, is demonstrating that local adaptation, honoring the reality of the mosaic, united under a sort of common paradigm, and an agriculture based on efficiencies inherent in the natural integrities (which haven't really been tapped), will make it possible for us to beat the pants off of industrial-input monocultures. Our Sunshine Farm—150 acres run on contemporary sunlight—is in its sixth field season. We're establishing an even playing field for comparison, eventually, of perennial polycultures with industrial-input farms.

Vaclav Smeil, an energy geographer, has asked people about the most important invention of the twentieth century, the most important and the most fundamental, in existential terms, for the largest number of people. He says nothing comes close to the Hobbler-Bosch synthesis of ammonia, first introduced in 1913 and commercialized after World War I. Synthetic nitrogen now supplies about half of the nutrients to the world's annual and permanent crops. Roughly one-half of humanity is now alive due to Hobbler-Bosch synthesis. So we can ask how many of the 5.3 billion global total population would be here without this nitrogen input and the natural gas that is the feed stock for it.

There's natural gas now, for fertilizers and petrochemicals, but ultimately it will be coal. Why do we have to constantly look to these non-renewables? That's a question that ought to be on everybody's plate. What goes along with petrochemical- and coal-derived pesticides, of course, is the introduction of chemicals we haven't evolved with. I mean this is the roundup now. It's turning out Roundup is not benign. We're going to see more and more cancers showing up. We're going to find social dislocation, and on, and on.

The Darwinian view says you don't put chemicals out there which we haven't evolved with. The Baconian-Cartesian view ignores this. So, this isn't just mere philosophy for the purpose of sounding erudite, it's hard. We're talking about something real.

What I'm getting at is that there is an alternative: the efficiencies inherent within the natural integrities of nature's ecosystems. These efficiencies have scarcely been tapped. We have to try to maximize our mimicry of natural systems in various places across the farming mosaic. In our projects at the Land Institute, we view the human as fundamentally a grass-seed eater; something like seventy to eighty percent of our calories globally come from the grass family. And we're lucky to be near a lot of grass-dominated ecosystems that we can look to to see how they worked. I love John Todd's language: elegant solutions predicated on the uniqueness of place. The homogenizer doesn't pay attention to that. ∞

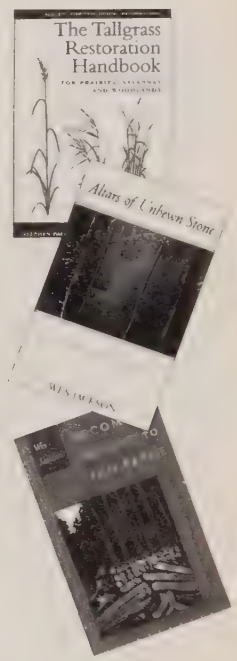

The Tallgrass Restoration Handbook. Stephen Packard and Cornelia F. Mutel, eds. 1997; 463 pp. \$25. Island Press. *Altars of Unhewn Stone: Science and the Earth.* Wes Jackson. 1987; 158 pp. \$12. North Point Press. *Becoming Native to This Place.* Wes Jackson. 1994; 121 pp. \$12.50. Counterpoint Press.

A DREAM OF ORANGES

by TERRY TEMPEST WILLIAMS

When we called the Church of Jesus Christ of Latter Day Saints for our special issue on Religion and the Environment (WE 91), and asked for their best speaker on environmental issues, they said without hesitation, Terry Tempest Williams. Her book *Refuge* has set the standard for writing about family life, naturalist prose, and dealing with enviro-tragedy. Reading *Refuge*, it's impossible not to cry or hear the cries of curlews and willets in early shoreline mist.

The image is this: a tree is standing alone in a field. Its branches are heavy with oranges. The oranges are peeled.

I was born in 1955 in Corona, California. Our backyard was an orchard of orange trees. My mother used to tell me that when I was a baby, just a few months old, she would hang a swing from their branches and let the warm breeze rock me to sleep. To this day, the sweet smell of orange blossoms elicits memories largely lost to me.

The orange groves of the San Bernardino Valley are long gone, razed tree by tree, acre by acre, for the tracts of houses to come. Paradise was replaced by suburbia.

Peeled oranges ready to eat. We didn't even see the fruit in front of our eyes, so set was our

vision on the fruit of our own desires. We thought our nourishment came from somewhere else.

Cut the trees.

Dig up their roots.

Pave the good soil.

Block by block by block, we have altered the land. We exist in boxes, cubicles. We drive to work, drive for more, more, more. Freeways. Beltways. The communities we now live in are called markets. We will take a poll before we will take our pulse.

Dead or alive?

Blood flows through our cities at night and we worry about crime, the crimes committed

against us. But what about the crimes we are committing? Criminy, we never even recognized the abundance of the world around us, the world we once had.

It is going, going—I pray I am wrong.

It is going, going—I pray I am wrong.

With my eyes closed, I take a deep breath and imagine myself swinging beneath the boughs of oranges, oranges peeled.

I hear the voice of Revelation, "What was once broken can now be healed." ∞



Refuge: An Unnatural History of Family and Place. Terry Tempest Williams. 1991; 304 pp. \$12. Vintage Books.



VISIONS FOR RURAL KENTUCKY

by WENDELL BERRY

Wendell Berry has farmed Kentucky soils and grown crops and abundant poetry, fiction, and essays—totalling now over thirty books. His is the superbly-crafted voice of rural America, especially its farmers; his clarity allows the toughest truths to be drunk with the greatest ease and pleasure. *A Timbered Choir* is his latest collection of poems. This essay is from a speech at the Family Farms Agricultural Roundtable. Originally printed in *Foresight*, a publication of the Kentucky Long-term Policy Research Center (800/853-2851).

A vision for rural Kentucky...is a subject I approach with a good deal of uneasiness, for I know something of the history of visions in rural Kentucky. The Bible says that where there is no vision the people perish. It is also true that where the vision is wrong the people perish.

In Kentucky we know that the important question is, "Who has the vision?" The coal companies have had a vision of the Kentucky coal-fields. The timber companies have had a vision of Kentucky forests. The tobacco companies have had a vision of Kentucky farms, and so have the packing houses and the grain dealers. The great agribusiness, timber, and coal corporations still have a vision of rural Kentucky, and in their vision the bottom dollar is always passing from the strong to the weak, and the top dollar from the weak to the strong. And of course rural Kentucky is always shrinking because of the visions of subdividers and developers.

The fact of the matter is that rural Kentucky is now more endangered than it has ever been. We are losing our farmers; the old are dying, the young are leaving. We have serious soil erosion. We are losing land to "development." We are in depression, and under threat. If you look for the money made from the products and the labor of one of our rural counties, you will see that very little of it is retained within the county line and not much more within the boundaries of the state. The story of these losses—of soil, land, farmers, economic resources and opportunities—is an ongoing story. We are going to be living with that story and its consequences for a long time.

I'm far from believing that rural Kentucky is a place for optimists. It would be unwise to risk underestimating the difficulties we are in. On the other hand, I do believe that rural Kentucky is a place for hope. I'm hopeful because I know, I have seen for myself, that we have people who are doing a good job, both as producers and as stewards of the land. And so I know that things can be better; we have good examples in front of us; abuse is not the inevitable consequence of use.

What I'm really nervous about is people who have visions for other people. Generally, I don't mind advice that begins, "Not bossing you or anything, but you could do it this way." But I *would* mind living in somebody else's political or economic or technological vision. I don't want to live next-door to a hog factory or chemical plant. I don't want to live where my community's fate and future will be determined by people who don't care about it. I know that some economies reduce freedom and economic opportunity.

The visions I am comfortable with are small-scale, private, inexpensive visions of improvement. There are no good farmers, probably, who do not see visions of the ways their farms could be improved: their farms could be more diverse, more productive, better fenced; there could be a wider margin between carrying capacity and numbers of livestock, giving comfort in dry years; there are scars that could be healed, woodlands that could be protected—and so on. I'm comfortable too with consumers' visions of fresher, healthier, more trustworthy produce from the local countryside, of farmers' markets, of ways in which local citizens could invest their money and work in a community-conserving and land-conserving local economy. I like visions that come from the spirit of neighborliness and care and thrift.

But even small, modest visions can be wrong. I know this from experience. If you visited my very marginal farm, you would see that I have had some visions that were right, and some that were wrong. I have had some visions that I could not have had if I had not been ignorant.

Our political principles of democracy and liberty are meant to protect our visions about how we want to live and work, and they're meant to protect us against other people's visions. But our political principles can't protect us from having the wrong visions about land use.

There is no doubt that we need a vision for rural Kentucky. We need, I think, a lot of visions for rural Kentucky. But if those visions are not to be (again) destructive and too costly, then we must take the trouble to know rural Kentucky and all its great diversity of landscapes, soil, economies, and natural and human communities. We must learn together to think from the ground up. We can't find the best ways of using and caring for our land just by forcing our visions and ideas upon it. The real question is how to fit in. How can human economies be fitted into nature's economies without finally destroying both? There's a thread of wisdom running through our cultural inheritance that says that everything depends on knowing where we are. It says that farmers and gardeners and foresters must consult the nature of the place. It says that in any given place there are certain things that nature will permit us to do without damage, certain things that nature will help us to do, and certain things that nature will penalize or punish us for doing.

To hold securely in possession and in trust a beautiful countryside, producing a dependable, healthful supply of food and other necessities, would be good for everybody. We don't have to destroy our land in order to live from it. We don't have to defeat and damage one another in order to prosper. There is a better way, and I think we're beginning to find it. ∞

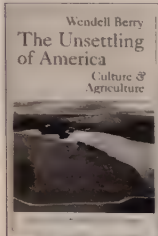

The Unsettling of America. Wendell Berry. 3rd edition, 1996; 234 pp. \$12. Sierra Club Books. **The Old Farmer's Almanac 1999.** 1998; 288 pp. \$4.95. Random House. **Seed Savers Heirloom Seeds and Gifts Catalog.** Seed Savers, 3076 North Winn Road, Decorah, IA 52101, 319/382-5990. **Seed to Seed.** Suzanne Ashworth. 1991; 222 pp. \$20. Seed Savers Exchange, 3076 North Winn Road, Decorah, IA 52101, 319/382-5990. **Small Farmer's Journal.** \$24/year (quarterly). L.R. Miller, editor/publisher. 325 Barclay Drive, Sisters, OR 97759, 541/549-4403.

MILLER / HUFEMAN
SMALL FARMER'S JOURNAL



OUTSIDE THE YUPPIE ZOO

by VINE DELORIA, JR.

Vine Deloria's intellect must be digested by every North American with an interest in this land's history, law, and religions. Spark of the American Indian renaissance, he flamed its flames with books like *Custer Died for Your Sins* and *Red Earth, White Lies*. I can think of no scholar with a more engaged and bracing mind. He's the former Executive Director of the National Congress of American Indians and a long-time rights advocate. His works are always war cries for a reasonable sense of perspective.

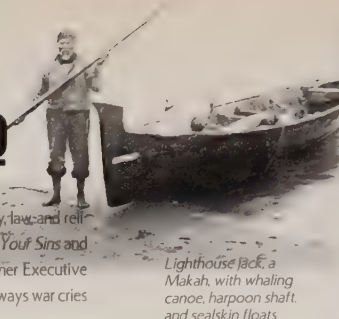

Lighthouse Jack, a Makah, with whaling canoe, harpoon shaft, and sealskin floats

Recently, after a hiatus of more than seventy years, the Makah Indians were authorized by the International Whaling Commission to hunt the grey whales with a maximum limit of five whales of a total estimated population of some 22,000 grey whales in the oceans. Refrigeration limits them to one whale. No sooner had the tribe announced its intention to proceed with the hunt than a bevy of animal rights activists and environmentalists declared that they would do everything they could to prevent this activity. Whaling had been the traditional practice of the Makahs and they have an elaborate ceremonial procedure to qualify people to go on these hunts. So the tribe began training people to handle the old canoes, familiarize themselves with the old harpoons, and learn the songs that had to be used to honor the whale during this ritual. A confrontation is expected at any time between the small tribe of Indians and the animal rights activists.

Several years ago the Inter-tribal Bison Cooperative, a coalition of some thirty-nine tribes, appalled at the needless slaughter of buffalo who had wandered outside the confines of their pasture at Yellowstone National Park, sought permission to take the surplus buffalo and move them to the various reservation buffalo pastures. This offer provoked cries of outrage by animal rights people who complained that the Indians would eventually shoot and eat these creatures and the adoption plan fell through. It seems as though each time the Indians try to regain the intimate relationship they once had with tribal animals, political correctness in some bizarre form comes charging into the situation. Yet it is also politically correct to envy the Indian relationship with nature and to dress up in Indian-style clothing and wander into the wilderness. What's wrong here?

About six years ago we had a rash of tourists in Rapid City, South Dakota being bitten by rattlesnakes at state campgrounds. It seems that they did not regard the snake as dangerous. Each year we have several incidents in western parks involving visitors frolicking or picnicking with local bears much to their discomfort when they discover that the bears are in fact hungry and aggressive. Rangers in Wind Cave National Monument have to be especially alert to prevent tourists from wandering into the buffalo herd to take pictures. People seem to be of the opinion that the animals that are humanized on television should immediately strike up a personal

relationship with them when encountered in the wild. Thus, the belief that Yellowstone bears are a western version of Gentle Ben is creating a hazardous situation for wildlife because they are the ones killed when a tourist is injured or frightened.

Modern people do not know what wilderness is, they are pretty oblivious to the fact that wild animals are still around and trying to survive in increasingly reduced habitats, and they appear to see the world as a special zoo created for their entertainment. Some kind of reality therapy is in order. While we treat the natural world as our plaything, it really does have an existence and values in and of itself. The natural world is not a yuppie zoo obedient to our wishes and fantasies. We have to give this world and its natural inhabitants some respect.

The Indians long ago devised ceremonies and rituals through which they ensured an intimate relationship with animals. Using songs, sacrifices, and religious practices, they became close to these creatures and learned the proper ways to deal with them. We learned from these animals, we did not expect them to act like us. Almost every piece of clothing or design featured these animals and special dances were done for them. We praised and sang to these animal peoples and they allowed us to hunt them for food.

Today there is widespread slaughter of many kinds of animals without ceremony, without honor, just simply a harvest. The number of whales, bears, and buffalo taken by Indians these days is minuscule compared to the commercial take. Yet animal rights activists, and white hunters and fishers, without any songs or honors, spend their time harassing Indians about various species, raising hardly a murmur against the real killers of these creatures. Enough is enough. Somebody needs to get a sense of proportion here. On reservations where tribes are raising these wild animals, their numbers are increasing—and they are living better lives and enjoying the attention lavished on them. They teach us many things that animal rights activists do not know. For their sake and our sake, we need to be able to continue the relationship. Enough is enough. ∞

Red Earth, White Lies: Native Americans and the Myth of Scientific Fact. Vine Deloria, Jr. 1997; 271 pp. \$16.95. Fulcrum Publishing, 350 Indiana Street, Suite 350, Golden, CO 80401, 303/277-1623. **King Solomon's Ring: New Light on Animal Ways.** Konrad Z. Lorenz. 1952; 202 pp. \$10.95. Penguin. **Anima Mundi** (video). Directed by Godfrey Reggio with music by Philip Glass. 1986; 30 minutes. \$14.98 (\$18.98 postpaid). Miramar, 200 Second Avenue W., Seattle, WA 98119, 202/284-4700. **Care of the Wild Feathered and Furred.** Mae Hickman and Maxine Guy. 2nd edition, 1998; 143 pp. \$15.95. Michael Kesend Publishing, Ltd., 1025 Fifth Avenue, New York, NY 10028, 212/249-5150. **Heart and Blood: Living with Deer in America.** Richard Nelson. 1997; 416 pp. \$14. Alfred A. Knopf. **Dawn of Art: The Chauvet Cave.** Jean-Marie Chauvet, Eilette Brunel Deschamps and Christian Hillaire. 1996; 136 pp. \$39.95. Harry N. Abrams, 100 Fifth Avenue, New York, NY 10011, 212/206-7715. **Witness: Endangered Species of North America.** Susan Middleton and David Liitschwager. 1994; 256 pp. \$50. Chronicle Books. **Just Space: Poems 1979-1989.** Joanne Kyger with illustrations by Arthur Okamura. 1991; 142 pp. \$12.50. Black Sparrow Press, 24 10th Street, Santa Rosa, CA 95401, 707/579-4011, www.blacksparrowpress.com.



DESTRUCTION

by JOANNE KYGER, 1974

Joanne Kyger has been an editor of her town's newspaper, the *Hearsay News*, for over a quarter-century. She teaches (aught me) journal writing and poetics—both locally and at the Jack Kerouac School of Disembodied Poetics (Naropa Institute)—especially how to give everyday life its proper due. Her poetry books are funny, lyric, leaping, exquisitely attentive to daily frustrations and suffering, and crafted with deft elegance.

First of all do you remember the way a bear goes through a cabin when nobody is home? He goes through the front door. I mean he really goes through it. Then he takes the cupboard off the wall and eats a can of lard.

He eats all the apples, limes, dates, bottled decaffeinated coffee, and 35 pounds of granola. The asparagus soup cans fall to the floor. Yum! He chomps up Norwegian crackers stashed for the winter. And the bouillon, salt, pepper, paprika, garlic, onions, potatoes.

He rips the Green Tara poster from the wall. Tries the Coleman Mustard. Spills the ink, tracks in the flour. Goes up stairs and takes a shit. Rips open the water bed, eats the incense and

drinks the perfume. Knocks over the Japanese tansu and the Persian miniature of a man on horseback watching a woman bathing.

Knocks Shelter, Whole Earth Catalog, Planet Drum, Northern Mists, Truck Tracks, and Women's Sports into the oozing water bed mess.

He goes down stairs and out the back wall. He keeps on going for a long way and finds a good cave to sleep it all off. Luckily he ate the whole medicine cabinet, including stash of LSD, peyote, Psilocybin, Amanita, Benzedrine, Valium and aspirin. ∞

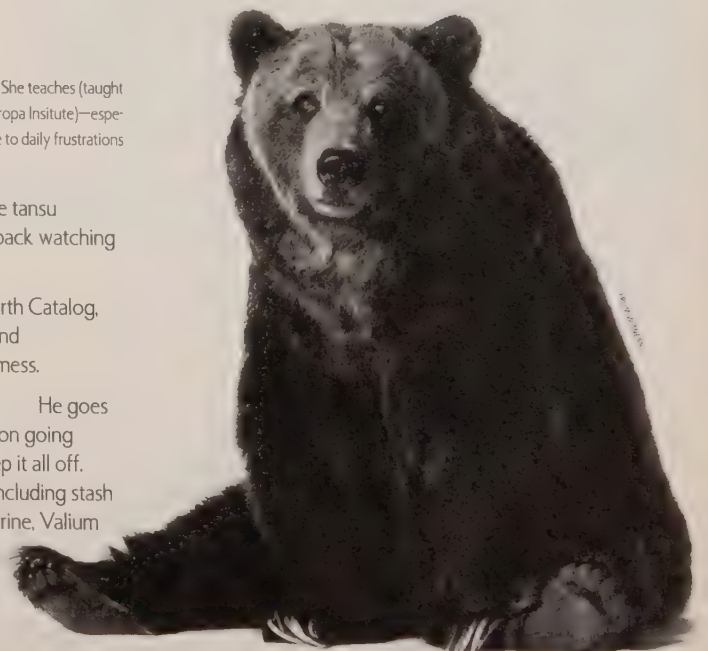

PATHS

CODE OF THE WARRIOR

by RICK FIELDS

Blood Rites: Origins and History of the Passions of War. Barbara Ehrenreich, 1997; 256 pp. \$14.95. Henry Holt. **The Awakened Warrior.** Rick Fields, ed. 1994; 267 pp. \$14.95. G.P. Putnam's Sons.

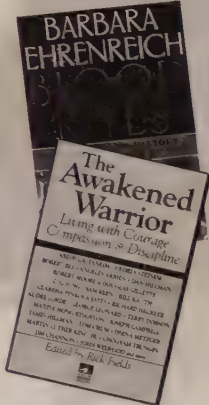

Rick Fields first wrote for Whole Earth about an experimental hunger fast in 1969. He wrote the first book on Buddhism coming to America (*How The Swans Came to the Lake*); recently co-wrote *Instructions to the Cook* (about a Zen priest caring for the homeless in Yonkers); has edited *New Age Journal*, the *Vajradhatu Sun*, and *Yoga Journal*; and contributed to Whole Earth on many occasions, especially on religion. His book of poems *Fuck You Cancer* (WE 94) is a revered, compassionate, funny, warrior-like guide for cancer sufferers. He calls himself a dyed-in-the-wool Buddhist, friend, teacher, GO player, heart brother—every joy that life's about.



The code of the warrior has the basic qualities of courage, loyalty and willingness to sacrifice for the larger group, to be connected to something larger than simply the individual. Human beings are group animals. Even though individualism is of a huge value for us, it's clear that none of us really can exist by ourselves, that our values were forged in groups, that human beings live in groups, and so one of the values of a warrior is being protective of the group no matter what the group is, or how the group is defined.

In her book *Blood Rites*, Barbara Ehrenreich quotes Israeli military historian Martin Van Creveld:

Given time, the fighting itself will cause the two sides to become more like each other, even to the point where opposites converge, merge, and change places. . . . The principal reason behind this phenomenon is that war represents perhaps the most imitative activity known to man.

Ehrenreich says,

There is a mechanism—almost a human reflex—that guarantees that belligerents will in fact be “given time” for this convergence to occur, and that mechanism is revenge: A raid or attack or insult must be matched with an attack of equal or greater destructive force. One atrocity will be followed by another; and no matter how amicable the two sides may once have been, they will soon be locked together in a process from which no escape seems possible. To the warrior, the necessity of revenge may be self-evident and beyond appeal.

At a certain point of history, the idea of not taking revenge arises as a religious idea. It arises in China, in India with the Buddha, and in the Middle East with Christ. And all of a sudden, somebody is saying “turn the other cheek” or as the Buddha says, “hatred is not ended by hatred.” This is very unusual. The question always is: what is the viability of a society that espouses these ideas in the face of societies that don't? And the answer is not very hopeful.

The Tibetans, for example, incorporated the Buddhist world view into what was a very active warrior society. China attacked and now the country is occupied, the culture is practically destroyed, the monasteries are destroyed, the women have been raped, and the whole country is physically occupied.

It seems that now there has to be a movement that says we're not going to buy into revenge. This is kind of a forgiveness, or seeing that a way out of this logic, out of this deadly logic, is more valuable than continuing the revenge cycle. It's always a scary thing. The code of the warrior takes a lot more than fighting the other side or conquest. It takes the courage to die. And the Buddha's notion of a Bodhisattva as somebody whose ideal is striving for enlightenment for the benefit of the other person takes great courage, and it takes seeing through the whole revenge cycle.

That's why I think that the Buddhist or the spiritual alternative is so incredibly important; because without some way to break that logic—

which is the logic of samsara—the suffering just goes on and on. When you think about the Bodhisattva vow in Buddhism, you know it's awesome to say that I'm giving up my own enlightenment in this lifetime, I'm giving up my own nirvana, I'm going to keep coming back into this world until all beings are eventually enlightened.

Humans are a mixture of ignorance and arrogance at the same time, which is a most dangerous combination. One of the things the species needs to do is to cut through our own arrogance, our sense that we know what we're doing, because we don't. And the other thing we need to do is to cut through our own ignorance. In Buddhism, this is the root problem that human beings have. That's why meditation and the development of wisdom are so crucial. And that's why the development of wisdom is seen as going hand and hand with the development of compassion. There doesn't really seem to be another possibility as far as I can see. And I'm not talking about Buddhism as a religion itself, I'm talking about that kind of approach to the problem.

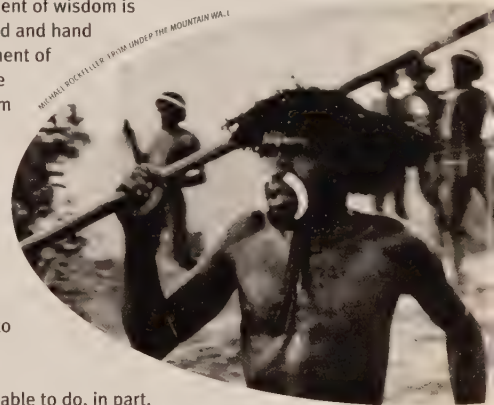

What Gandhi was able to do, in part, was appeal to the British code of the warrior, a sense of fair play and respect, but he spent a lot of time in jail. Ultimately, when somebody wanted to kill him, they killed him. And the reason they wanted to kill him was because they thought that he was giving in to the idea of a Muslim state. It was a Hindu nationalist who killed Gandhi—not a Muslim—and that in turn unleashed massacres; a lot of people died. So it's a question of how successful that strategy was, as admirable as it might be, or might have been. Gandhi himself said that the person who faces a cannon without another cannon is a braver warrior than the one who simply fights back. That takes a great amount of warrior virtues, of discipline, of courage, of sacrifice, of all those things. You have to be highly motivated and highly trained. It only worked because large masses of people revered Gandhi so greatly.

So, in the *Code of the Warrior*, I end with a little chapter on bringing the warrior down to earth, where Ed Abbey says the idea of wilderness needs no defense, it only needs defenders. So Earth First ends up being a kind of warrior society; it takes on a particular code of, say, nonviolence because of the recognition that if you use force against the nation-state, the state will seek revenge and you will be crushed. So you're sort of looking for a kind of jujitsu. You have to be smarter, figure out how to use the power of the state against itself or to get out of the way of the state. Or you pledge yourself to nonviolence, which only really works when things have progressed far enough that people respect it.

Sun Tzu says that the greatest general wins by not fighting. In Aikido, you do the same sort of thing. You fight by using your enemy's aggression against himself, not by meeting him head-on in battle, but by deflecting his energy. We all have to figure out a way to do that or else we're caught perpetually in the situation we're caught now: no matter what, warfare seems to go on. Warfare has its own kind of energy. ∞

Autobiography: The Story of My Experiments with Truth. Mohandas K. Gandhi translated by Mahadev Desai. 1948; 480 pp. \$9.95. Dover. **Gandhi on Non-Violence.** Mohandas K. Gandhi, edited by Thomas Merton. 1964; 82 pp. \$5.95. New Directions Publishing Co..

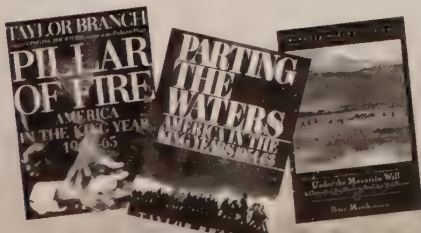
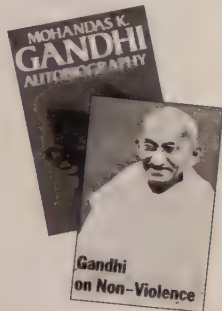

The Art of War. Sun Tzu. 1996; 92 pp. \$9.95. NewStar Press (formerly Dove Books), 8955 Beverly Boulevard, Los Angeles, CA 90048; 310/273-7722, www.newstarmedia.com. **The Transformation of War.** Martin Van Creveld. 1991; 253 pp. \$29.95. Simon & Schuster. **Pillar of Fire: America During the King Years 1963-65.** Taylor Branch. 1998; 746 pp. \$30. Simon & Schuster. **Parting the Waters: America in the King Years 1954-63.** Taylor Branch. 1989; 1038 pp. \$16. Simon & Schuster. **Under the Mountain Wall: A Chronicle of Two Seasons in Stone Age New Guinea.** Peter Mattheissen. 1962; 272 pp. \$12.95. Penguin.

PATHS CHOSEN

The first Catalog said "We are as gods and might as well get good at it." Readers pow-wowed these words endlessly. "Well," said Rick Fields, "gods do have power over life and death and so do humans. We better get good at understanding our powers." Various readers have chosen different and simultaneous paths/roads/arteries—spurred on, perhaps, by different divinities. They have all tried to get good at it

Phil Frank took on the gargantuan task of illustrating and simplifying Whole Earth's schema of some chosen paths. In the cartoon, we start on our ideal path (on the signpost). At the trail's end, the top of the pyramid shows who gets the glory: humans or gods/goddesses or Nature. In the pyramid's lower left corner is its strong foundation. The lower right corner is crumbling, the weak foundation. For instance, the Hero's Path finds glory in humans (top) and support from the gods/goddesses (lower left), but gives little value to Nature (lower right). Phil Frank had two nationally syndicated comic strips but opted for local distribution in the *San Francisco Chronicle* to emphasize topicality and timeliness. His book on wild bears will appear in 1999

IDEAL FOR TRAIL BLAZER

HERO'S PATH

HEROES
VICTIMS
PERSECUTORS
ENCHANTERS
MAGIC TOOLS
TRICKSTERS

COMBAT
ROMANCE
ENDING CHAOS
STOPPING MONSTERS

LEGENDS AND MYTHS

END OF TRAIL MARKER

HUMANS
A DRAMATIC UNIVERSE
GODS
GODDESSES
NATURE

The Divine Way

Reduce pain and suffering.
Do good deeds.

SOULS
CONGREGANTS
PILGRIMS
PRIESTS
GURUS
SAINTS
PROPHETS
SPIRITUAL CLOWNS

SERVICE
RESPECT
WORSHIP
RITUAL
MEDITATION
YOGA

PRAYERS, SCRIPTURES, HOLY IMAGES AND ALLEGORY

GODS
GODDESSES
A PEACEABLE KINGDOM
HUMANS
NATURE

The Democratic-Scientific Path

TRUTH
EQUALITY
SOLIDARITY

CITIZENS
POLITICIANS
SCIENTISTS
PHILOSOPHERS
DOCTORS
LAWYERS
STATISTICIANS
SATIRISTS

REASON
PARTICIPATORY DECISIONS
DEVELOPMENT
MATHEMATICS
LOGIC

LOGICAL ARGUMENT
ESSAYS, CHARTS, NOVELS

NATURAL RIGHTS
A JUST SOCIETY
HUMANS
GODS
GODDESSES

THE ECONOMIC TOLLROAD

Material well-being
Comfort
Free Time
Success

OPEN 24 HOURS

CONSUMERS
PRODUCERS
TRADERS
MANAGERS
INVENTORS
GAMBLERS
SITCOMS

COMPETITIVE ADVANTAGE
SUSTINENCE
STRATEGY
GROWTH
NUMBER CRUNCHING

ADVERTISING, FORECASTS, PACKAGING, THE WEB

ALL NEW FOR 1999!

SALE TODAY ONLY

A CIVILIZATION TO REMEMBER
HUMANS
GODS
GODDESSES
NATURE

CURRENT SPIRIT PATH

RESPECT
UNSEEN POWER
WONDER
INTERDEPENDENCE

THE PEOPLE
SHAMANS
TRICKSTERS
CLOWNS
ELDER
PATHKEEPERS
ANIMA PEOPLE

SHAMANIC JOURNEYS
PERSONA TRANSFORMATIONS
HEALING
PERSONAL WORSHIP OF LIFE'S SOURCES

RITUAL DRAMA, ORAL TALES, VISIONS, "FETISHES", BLESSING WAYS

NATURE
HUMANS
DIVINITIES
HARMONIOUS RELATIONSHIP WITH ALL CREATURES

Phil Frank



THE EXECUTIONER'S FORK

by JO SMITH

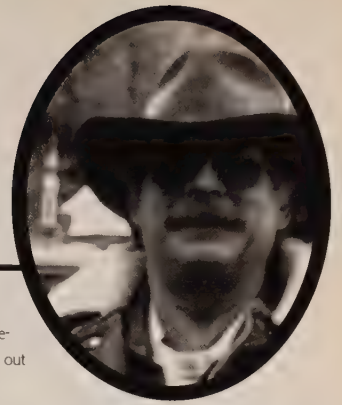

You meet friends of JD at the best places on Earth, like the put-in for an eighteen-day raft trip through the Grand Canyon. If early Catalogs were thought to be bibles of the back-to-the-land movement, blame JD. He managed the Whole Earth Truck Store, edited the fall, 1970 Whole Earth Catalog, was Editor/Janitor of CoEvolution Quarterly No. 8, on land. He churns out remarkably tight short short stories from an incredible memory, given what we all imbibed. He's now living outside Weston, Oregon, "trying to write for a living before I stop living."

The Innocents Abroad or The New Pilgrims Progress. Mark Twain. 1869; 492 pp. \$6.95. E.P. Dutton. **On the Road.** Jack Kerouac. 1955; 254 pp. 12.95. Penguin. **Personal Narrative of A Pilgrimage to Al-Madinah and Meccah, Volume I and II.** Sir Richard F. Burton. 3rd edition. 1893; 480 pp. each. \$11.95 (Vol. I), \$10.95 (Vol. II). Dover. **Orbit.** See access, p.62. **The Songlines.** Bruce Chatwin. 1987; 295 pp. \$13.95. Penguin.

In the fall of 1968, five of us were trying to live together in three bedrooms, a kitchen, and the one bath of a stout white apartment building near Harvard Square. Charles, the producer of the unfinished film that gnawed at our waking lives, shared the room he reserved for worrying and tossing in his sleep with Beryl, who ate only with chopsticks and spent her days with runes and Tarot cards.

I'd dropped out of graduate school to operate a Nagra tape recorder for Charles as he ran his lens across the new consciousness developing in the Haight-Ashbury. In Cambridge my friends were dealing blond Lebanese hashish. I bunked in a sweaty leaded-glass turret with a radiator that sounded like it was puking hailstones. There were brown roses on my wallpaper. If I pressed my thumbs on my eyes, just so, the roses swirled, collided, and turned pink.

On the third floor, in twin beds placed as separately as possible in a twelve-by-twelve room, slept Eva and Ladd, two New York film editors who had been dropped into Charles' art by the television company which had underwritten our voyage to San Francisco and two hundred hours of footage of the Summer of Love. The company was hungry for a return on its money. The film simply must be cut, soon, they insisted. Charles believed the film would bloom from his vision.

Eva was a shy crossword-puzzle addict with the professional fingers required to splice film precisely and quickly. She missed her two cats, Honey and Muhammet. She wanted to finish the film and get back to New York. She waxed her shoes nightly and disliked stepping on the leaves that cover everything in Cambridge in October.

Ladd talked loudly, chewed with his mouth open, and limped. He showered Eva with harsh direct commands. He used the triple-negative "No, no, no." when he disagreed with Charles. Charles considered Ladd to be the antithesis of the film's content, but he could

not bring himself to terminate Ladd's employment. The whirling dance of Golden Gate Park rapture had softened Charles' approach to vermin. "Do ants believe?" was the central question of his new theology.

So Charles stewed and the film sank slowly into a month of muddy indecision. Eva carried bundles of *New York Times* crossword puzzles to work. I painted the editing room floor. Ladd spent hours on the phone with New York. Beryl whittled bundles of chopsticks from elm twigs with a kitchen knife.

Until one Sunday morning...

We rotated the cooking chores for our communal Sunday breakfast at the grey and chrome table in our kitchen. It was Charles' morning to cook. He carefully sculpted twenty crepes on an upside-down cast iron frying pan, opened a quart of his mother's Indiana apple butter, squeezed a gallon of fresh orange juice, whipped a quart of cream, sweetened it with maple syrup, brewed coffee with chicory, then whacked the wind chimes to call us to the table. We all came a-running, except for Ladd, who was chronically late for everything. Way up in the attic we heard him swing his locked knee off the side of his bed and begin to dress.

Eva, Beryl, and I politely sat at attention, sipping coffee, watching the crepes cooling and the cream deflating, while Charles slouched with his chin on his chest, tracing his fingers back and forth along the chrome molding on the table's edge. Ladd thumped down two flights of hardwood stairs and into the bathroom, where he hummed a piano concerto while he operated his electric razor.

The kitchen air smelled of lightning and aluminum by the time Ladd nudged Eva forward, hooked the crook of his cane over the chair at the small of her back,

waved his napkin twice before placing it in his lap, smiled, and said, "By God, let's eat."

As Ladd reached across the table to yard the entire plate of crepes closer to his grasp, a knotted leather button on his camel hair blazer caught in the tines of a fork beside his plate, and the fork sprang off the Formica and down onto the checkerboard linoleum floor. It rang like a sleighbell.

That tiny tinkle brought Charles to critical mass. He leaped from his chair, pointed to the fork as though it were a viper, screamed at Ladd, "You are fired, you bastard!" then stormed out of the front door, off the verandah, and into the orange Harvard Square streets.

Beryl plucked at a crepe with her new chopsticks. Eva took the cane from the back of her chair, leaned it against Ladd's knee, and said "I shall not be accompanying you." Ladd sat dumbfounded and grave for a few moments, then struggled back up the stairs.

I ate the bowl of whipped cream, then went in search of Charles. I found him reading Friday's *Variety* over a bowl of noodle soup in a Hayes-Bickford cafeteria filled with hangovers. We finished the film in a week, then I drifted back toward California. ∞



What Color is Your Parachute? Richard Nelson Bolles. 1998; 560 pp. \$16.95. Ten Speed Press. **The Seven Laws of Money.** Michael Phillips. 1974; 128 pp. \$9. Shambhala Publications.

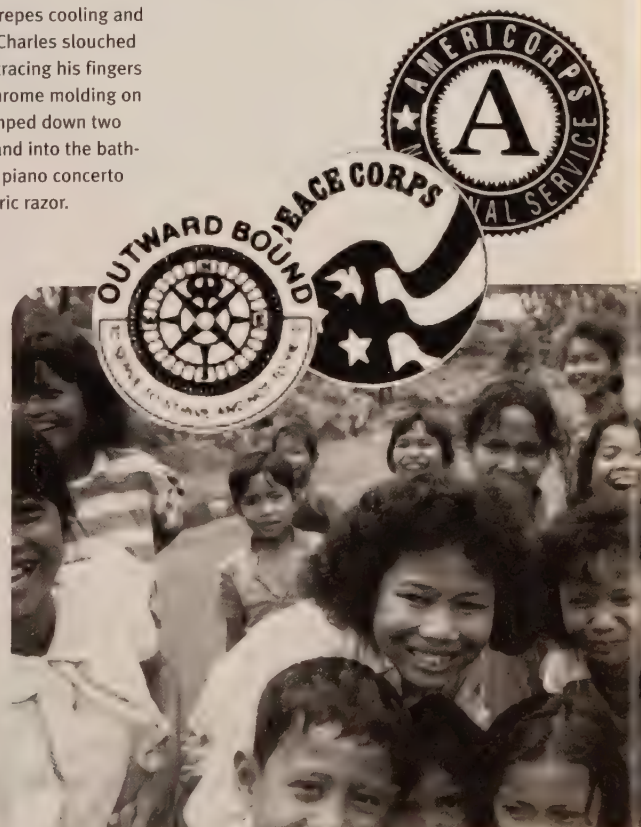
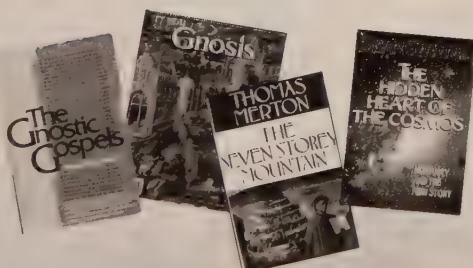
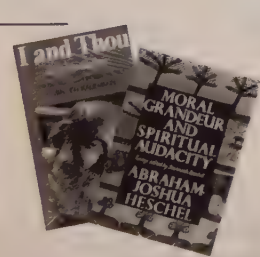
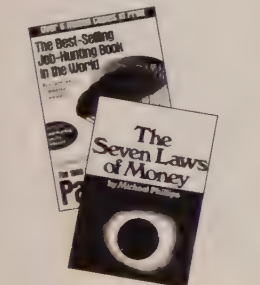

SF.ZENDOQ@POLITICS.HEART

by PETER COYOTE

Although he's an actor, Peter has no masks. He's a Marin local dedicated to local culture. He performed on the barricades with the SF Mime Troupe, went on the road with the Diggers, served as Chair of the California Arts Council funneling funds to local artists. Like many who have been "on the streets," he's sharp, honest, clear, and dramatic. Now a well-known actor, Peter does narration for scores of documentaries that push for self- and societal change. He's kindly been our advocate with local foundations, helping to keep Whole Earth financially alive.

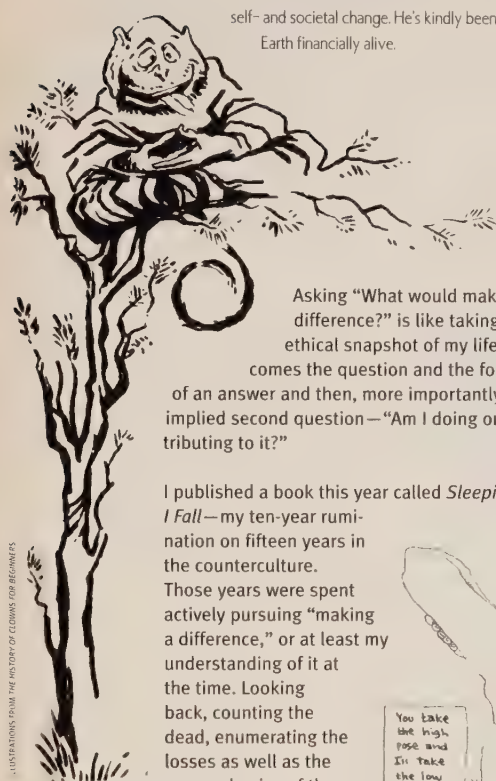
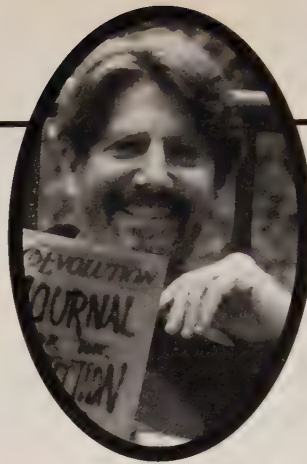

Asking "What would make a difference?" is like taking an ethical snapshot of my life. First comes the question and the formulation of an answer and then, more importantly, the implied second question—"Am I doing or contributing to it?"

I published a book this year called *Sleeping Where I Fall*—my ten-year rumination on fifteen years in the counterculture. Those years were spent actively pursuing "making a difference," or at least my understanding of it at the time. Looking back, counting the dead, enumerating the losses as well as the very real gains of the eighties and nineties,

it all boils down to a rather simple dictum: "If you're not working on your self, you can be sure the world is eroding it."

I say this not to support the contingent of cappuccino-quaffing ESTers and New Agers I stumble across in my sojourns into Whole Foods, who are as greedy for "the best of everything" as they were for stockmarket returns in the eighties. The "self" I'm thinking about these days is the vague and shadowy presence I began to hunt in Zen practice twenty-something years ago. Because in practice, the problems I have spent my life addressing emanate from the fixed (but wrong) conviction of that self as an isolated entity in a hostile and dangerous universe.

That is the root of the problem for me, and addressing the greed, hatred, and confusion which are rooted in the human breast, investigating the fear and loathing of self which is disguised as fear and loathing of the other, is the most important single thing that I can think of to do. Cut the damn problem off at the roots; strike to the heart of that which recapitulates and recombines itself eon by eon, generation by generation, creating discord, violence, folly, and pain endlessly.

This is not to say that there is not specific work in the world to do (right livelihood, issue-oriented politics), but that unless these projects are pursued in a truly "selfless," inclusive manner, we are, like Penelope, wife of Odysseus, unwinding daily what we weave. Unlike Penelope, we are usually unaware of it.

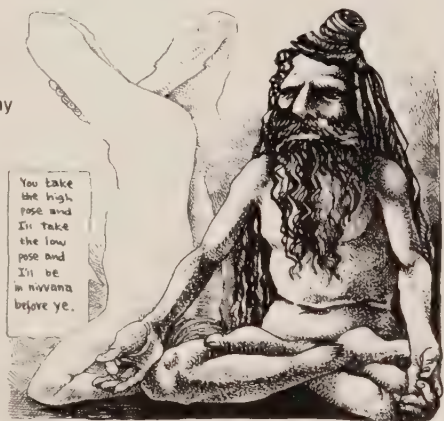

The second question, "Am I doing it?" is trickier to answer. I sit zazen (Zen meditation) daily, though I'm about a year overdue on sitting a sesshin (the week-long intensive meditation session that offers enough meditating to facilitate breakthroughs of insight). I try to make meditation an ongoing, daily practice, even down to the simplest act of taking a breath and letting it out slowly and consciously before I answer the phone.

I work in politics, particularly environmental and Buddhist issues, and have come to think that in the political sector absolutely nothing will change without radical campaign finance reform that will force the political class to once again work for the people. There are four changes that I think could radically alter politics in America as we know them:

- 1) Full funding for all elections and a ban on soft money. (This means overturning the Supreme Court decision that the giving of money is an expression of free speech—a patent absurdity.)
- 2) Free airtime for all qualified candidates on our public airwaves and on all major TV stations.
- 3) In return for free airtime, all candidates must pledge to appear in unstructured debates on each network, and answer questions in town-hall-like meetings.
- 4) Extending to citizens and nonprofit groups the same write-off for disseminating information that private industry takes when it actively subverts the public interest by holding hands-off, dog-and-pony show "informational seminars" designed to influence the public and win votes.

These four steps would go a long way towards redirecting the attention of the political class towards the people.

Does any of this make a difference? Well, you can't pour a quart into a pint pitcher; you cannot ever make the world less than everything, so I am under no illusion that greed, hatred and delusion in all their multiple guises will ever disappear. Having said that, however, I guess I do believe that the proportions and dominance of them in our public life can be altered, will be altered if enough people manifest the intention of enlightenment, the intention of public good will, compassion and generosity. I suppose that I persevere on both fronts, the personal and the public, not because I believe that it will make a difference, but because it is, finally, the way in which I want to live, the way I want to be as a human being, the order of mind I want to make manifest in the world. What else is there to do? ∞



Sleeping Where I Fall. Peter Coyote. 1998; 367 pp. \$26. Counterpoint Press.



The History of Clowns for Beginners. Joe Lee. 1995; 180 pp. \$11. Writers and Readers Publishing, Inc. *Zen Mind, Beginner's Mind*. Shunryu Suzuki. 1970; 138 pp. 7.95. Weatherhill. *The Way of Life According To Lao Tzu*. Witter Bynner, translator. 1944; 109 pp. \$8.95. Penguin.

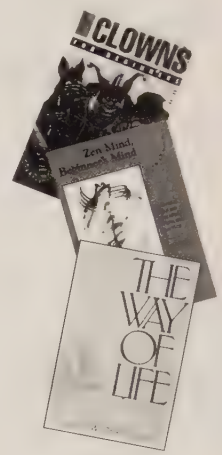

The Hero With a Thousand Faces. Joseph Campbell. 1990; 464 pp. 14.95. *Kinds of Power: A Guide to Its Intelligent Use*. James Hillman. 1995; 272 pp. \$12.95. Doubleday.



I and Thou. Martin Buber. 1976; 192 pp. \$10. Simon & Schuster. *Moral Grandeur and Spiritual Audacity*. Abraham Joshua Heschel. 1996; 425 pp. \$15. Farrar, Straus and Giroux. *The Gnostic Gospels*. Elaine Pagels. 1989; 224 pp. \$11. Vintage Books. *Gnosis: A Journal of the Western Inner Traditions*. Jay Kinney, publisher/ editor in chief. \$28/year (quarterly). PO Box 14217, San Francisco, CA 94107, 415/974-0600. *The Seven Storey Mountain*. Thomas Merton. 1948; 429 pp. \$15. Harcourt Brace. *The Hidden Heart of the Cosmos: Humanity and the New Story*. Brian Swimme. 1996; 115 pp. \$15. Orbis Books, Box 308, Maryknoll, NY 10545-0308, 914/941-7590, www.maryknoll.org/orbis/mklorbhp. *Outward Bound*. Route 9D, R2, Box 280, Garrison, NY 10524-9757, 914/424-4000, 800/243-8520, www.outwardbound.org. *Peace Corps*. 1111 20th Street, NW, Washington, DC 20526, 703/235-9191, www.peacecorps.gov. *The Sufis*. Idries Shah. 1964; 480 pp. \$14. Doubleday. *AmeriCorps*. 1201 New York Avenue, NW, Washington, DC 20525, 202/606-5000, 800/942-2677, www.americorps.org. *The Sacred: Ways of Knowledge, Sources of Life*. Peggy V. Beck and Anna Lee Walters. 1977; 368 pp. \$24.95. Navajo Community College Press, Dine College, Tsalle, AZ 86556, 520/724-6635.

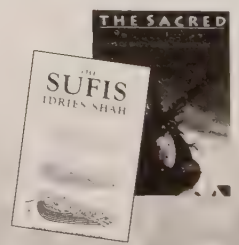

MAKING STUFF

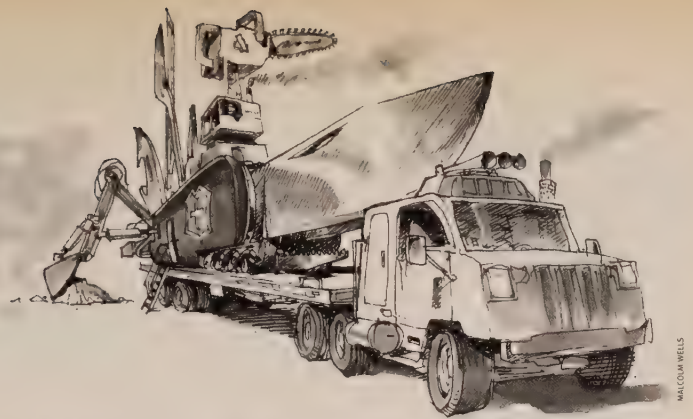

THE ULTIMATE SWISS OMNI KNIFE

by J. BALDWIN

J. Baldwin is Whole Earth's heart, its sense of legacy, its hand-tool expert, an inspiration to students of design, a conversational and impeccable reviewer on myriad topics, a carrier of Buckminster Fuller's wisdom (see access for his *Bucky Works*, p. 62 in 1968 Catalog), and a superb model for how to live simply with a super-rich mind. Recently, he's been working with Rocky Mountain Institute on their pioneering work on electric cars.

"We were put on earth to make things." —W.H. Auden

Always curious (and possibly wacky), I kept track of how many times I deployed my trusty Victorinox Champion Swiss Army® knife last year. Two-thousand-and-eight. That means it has helped to solve about twenty-six thousand little problems

since I hired it in 1985. Yet there have been at least as many times I cursed its liver for not having the blade needed for the job at hand.

People have always hungered to correct pesky failures, to implement their inspiration, to physically flaunt their know-how. Is it possible to make a Swiss Army Knife or other tool that can handle any likely situation? We're talking augmented physical capability here, and it's certainly a desirable and even enticing goal for many folk—witness the rising tide of all-purpose belt-sheathed tools flooding the market these days. (All are OK. None are entirely satisfactory, nor can they be.)

Computers also qualify as design tools. With a CAD (Computer Assisted Design) program, for instance, a computer can help the designer by depicting size, shape, and color in easily editable form. Iterative versions can be tried quickly and affordably. CAD eases tiresome chores by calculating and displaying stress and strain, costs, production schedules, for each new version. Widely separated designers can work together online.

But electronic tools of analysis and simulation can merely display attributes. Heft, drape, scale, tactility, and wieldliness can only be intimately assessed by engaging a real object. You can't sit, much less get comfortable, in a virtual chair, however nifty it looks onscreen.

In fact, computer representations can mislead—and frequently do. Two- or three-dimensional CAD renderings can neither predict nor project complex and often subtle interactions with the actual world. They can help refine an idea, but they cannot innovate or identify opportunities for synergetic advantage. Intriguing and essential design nuances in computerized representations tend to be reduced to this-or-that choices—abdicating the exactly-right-size and mysteriously exquisite contours that remain unrealized in the artist/artisan's intuitive mind.

Nothing simulated can equal the thrill of taking a design concept from napkin-sketch to physical viability. Even the most electronically sophisticated thing-making corporations have discovered the advantage in moving from keyboard-and-screen to the shop floor as soon as possible. Artists and hand-crafters already know why; they've always been there.

A CRAFTER'S MANIFESTO

Human handling and manipulating of materials and the tools that work them, as well as making and testing your own prototypes, ensures that nothing gets lost or diluted in the translation from thought to thing. Know-how, and the equally essential know-who, are born and bred at the metaphorical workbench and coffeepot, then spread through trade journals and the Internet.

Human inventions and capability (for both good and ill—as always) are increasing at a furious pace. Managing this torrent in a way that avoids serious insult to society and the rest of nature is proving to be difficult. As awareness of the effects of our actions sharpens, we must now ask an uncomfortable question: can any art or craft be truly worthwhile and wonderful if it engenders an environmental mess and ruined lives elsewhere?

Buckminster Fuller noted that "Good hardware is one of the few irrefutable proofs of clear thought." (Today, he might have included software.) But how much is too much? And the toughest question: should we be doing this at all?

If the answer to 'should we?' is yes, then we need to proceed using the least resources over the lifetime of the product. The same making-things-right principles that apply to industry apply to art, personal do-it-yourself projects, and even to repairs. Fuller also recommended that we consider our proposals comprehensively, anticipating the long future in all we do, always integrating our know-how with good science and deep wisdom.

You might think that this is obvious, but apparently it isn't. Had thousands of computer programmers and designers comprehensively anticipated the future, we wouldn't have those pesky and fearsome prognostications of Y2K disaster coming at us. Comprehensive thinkers attend the connections.

The same narrow-focused designers also missed or ignored the enormous environmental costs of computer-making: a single chip presently involves (among other things) about twenty-five pounds of assorted chemicals, nine pounds of toxic waste, and the pollution of 2,000 gallons of water.

Electronic tools evolve very quickly to become ever more useful. Hand tools evolve more slowly, but evolve they do, as experience continues to accumulate. Hammers don't go obsolete yearly, but they are undergoing further refinement, spurred by a new understanding of ergonomics and the need to reduce crippling "carpenter's elbow." Burgeoning interest in handcrafts is even bringing back forgotten oldies-but-goodies such as the "Cheney Nailer" (from Lee Valley, 800/871-8158), with a grooved, magnetized head that holds nails in place for one-handed pounding (see illustration).

ARE CRAFTS THE ANSWER TO DIGERITIS?

Specialty tool catalogs are getting fatter by the month. Model-making, jewelry, weaving, gardening, auto restoration, wood-and-metal-working—just about any handiwork you can name—have their own tools and catalogs, made all the more fascinating by matching catalogs of materials, components, and supplies. See, for instance, the implements of surgery and dentistry offered to model makers, antique-restorers, and electronic experimenters.

The astonishing number of tool catalogs available since the first Whole Earth Catalog is proof that the rise of virtual tools has ignited a similar boom in analog action. If they were added together, you couldn't haul the Noah's Ark of craft tools and small machinery in a fleet of forty-ton eighteen-wheelers, much less on your belt or loose in a flimsy pocket.

You can, however, easily haul know-how, know-who, and the ever-easier, more precise know-where-to-get-it. Besides your head and hands, the most useful all-purpose belt tool is the one that most closely matches the normal negotiations of your everyday life. I have several. One of them is custom-made (by my tool-savvy goldsmith wife, Liz) for my role as land steward. There is no snakebite kit included these days; ranchers have found that the best antidote is a (belt-mounted) cell phone.

Our "Highly Evolved Toolbox" prototype-shop-in-a-truck is really just a belt tool writ large. Like belt tools (indeed, like all toolkits of any size), it has a practical size limitation and is constrained to work within its capabilities.

Nothing new here; 'twas ever thus: The unlucky "Iceman" recently found frozen in the Alps was so equipped—thousands of years ago. Perhaps he just lost or broke something critical. Or maybe, in a fit of hubris inspired by his tool-augmented powers, he was the first to venture into alpine territory, realizing too late that newfound capability without wisdom is not sufficient. Like a young rabbit that doesn't realize there are Great Horned Owls until it feels the fatal talons clench its back, I doubt that we are any less vulnerable. ∞

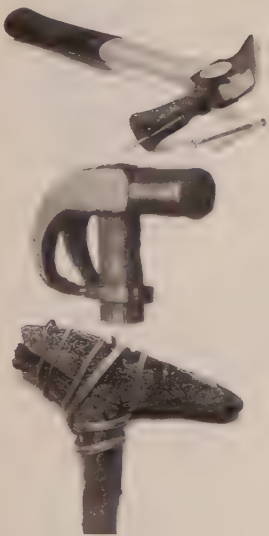

Top: Lee Valley's "Cheney Nailer." Middle: The first hammer ever patented (1845). The Art of Fine Tools. From the collection of Bud Steere. Bottom: Stick Bundle by Chris Drury. Photograph by Ian Cameron from Chris Drury; Found Moments in Time and Space published by Harry N. Abrams Inc. © Cameron Books



The Art of Fine Tools Sandor Nagyszalanczy, 1998; 232 pp. \$37. Taunton. Lark Books Crafts Books Catalog Lark Books, 50 College Street, Asheville, NC 28801, 704/253-0467, www.larkbooks.com.

CONSUMING STUFF

WHEN, IF EVER, IS ENOUGH ENOUGH?

by STEVE BARNETT

Steve Barnett is our great gadfly from the corporate world, a prized and generous member of our editorial board. He is vice president for global consumer trends at Citicorp. We shared time in Paris studying anthropology with Louis DuMont and Claude Lévi-Strauss. Steve lived in small villages in India and has, if anyone has, experienced and thought pragmatically about the gargantuan distances between very rich and very poor

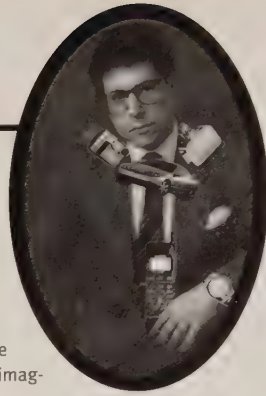

JEAN - Can't help noticing how you've changed since we both read *Whole Earth* in college. Two cars plus an SUV, a voluminous house, home entertainment center, separate freezer, three PCs—are you happier?

RACHEL - Surprise you? I am. Always wanted some of these goodies. Other things we need as a family. My husband and I both drive to work, the computers help the kids' school grades, and they need lots of space for their soccer stuff and just because they're kids. Hey, why am I justifying these purchases?

JEAN - Because of their consequences. Our family lives with lots less. We have more time and energy to do what matters most. All of us think for ourselves—we're not pushed around by ads or the culture's insistence on how to live. We bike when we can, and if you don't provide excess space, you'd be surprised at how efficient your kids become. Plus, we feel more responsive to the global implications of never-ending consumerism. In short, Rachel, we're a better model for our children.



FROM MATERIAL WORLD

RACHEL - Very pious, very PC. Haven't I heard this before? Dictate priorities. Force a kind of global egalitarianism. Your ideas are a throwback to sixties radicalism—Marxism transformed into Earth First. "The West must shrink its consumption 'til we match slightly better-off non-Western economies." We live too far from work and school to even think of biking.

We humans don't know enough to support your doom-and-gloom. We can't predict the future effects of consumption. Efficiencies of production continue to limit environmental consequences. The more the consumption, the greater the incentive for efficiency. Nanotechnology, bioengineering, superconductivity, and who knows what else could make increased consumption and sustainability compatible. Amory Lovins says we could use one-fourth of the energy and materials we do now to make the same amount of consumer goods. Some say we'll be able to reduce all that by a factor of ten.

JEAN - If we don't know enough to support my position, then we definitely don't know enough to support yours. You accuse me of being pious, yet your god is a just-in-time techno-fix. How convenient and prescient: new technologies will be perfectly suited to salvage ever-expanding consumer desires. Technologies' impact on overall consumption isn't clear. This is just techno-astrology, rationality pushed into a future that cannot be predicted. Preemptive caution is the only course that makes sense.

As for the sixties radical charge, I plead semi-guilty. But your ideology—"you are what you consume"—is an ideology stuffed down the throats of people by pervasive advertising. It all boils down to the shallow notion of having a lifestyle rather than having a life. It's an infinite regress of envy where enough is never enough. Rachel, you choose to live far from work, you choose how many children you have. Other choices are possible.

RACHEL - Your hidden agenda's revealed. Voluntary simplicity. Or perhaps you are more dogmatic and want a government-imposed "voluntary" sim-

plicity. Maybe the Cultural Revolution!

What would you substitute as an acceptable "ideology"? Gaia worship, small is beautiful, a William Morris-esque return to village craft? Have you tried to imagine the kind of government that could force such a profound shift in values? You think consumerism is "false consciousness," as if it's merely a sleight-of-hand substitute for the search for genuine meaning. But what is genuine? And how can you know, let alone impose it on others? We don't "choose" where to live in a vacuum. There are housing costs, taxes, school quality; things like that matter.

Enough, in fact, is never enough.

Consumption does confer benefits and I want my kids to have every advantage I can give them. We didn't know in the sixties that we'd be buying personal computers, and we don't know now what the equivalent of computers will be in the future.

Who knows? Perhaps in the end virtual consumption will reduce actual consumption and take care of some of your environmental concerns. Not only is increasing consumption the only way we can think of right now to improve the lot of newly industrializing countries, it will probably transform itself out of the problems which so concern you.

JEAN - So-called advanced countries will not cut back on their material wealth nor share their educational resources to put right these inequities. I've lost that idealism. They could, of course. But post-modern people are unwilling to give even of their surplus to those in need. Yes, I am probably among the very few who would deny themselves material wealth in favor of simplicity. It's not Marxism nor Earth First. I now see the economic explosion is due to the immaturity of the human soul, which cannot do much to overcome its egocentric impulses. That's what I want my kids to learn: the contentment of less hungry egos; the quietness and beauty of the human spirit, if not of Nature, without the need to dress it up all the time. Buying is not being.

RACHEL - There are learned folks who argue that we can consume much more. But I don't think they'll convince you. Your worst nightmare is people like me who both love and need to consume, who deny bad consequences, and who think the spread of market economies is the only hope for the world's poor. The worst of slums and low wages will pass, just as they have in Western countries.

JEAN - Mutual nightmares then. I would restrict your unbridled access to what are, in effect, the planet's resources, whether by a pricing system that takes into account environmental costs or by government rules or, my best hope, through personal transformation. Muddling through isn't a guaranteed solution, especially since it doesn't change the way we think about who we are and our place on Earth.

RACHEL - We've muddled through successfully in the past. Maybe I should be more scared of overshooting sustainability. Maybe it's our age, Jean, but muddling through seems like the only option left. ∞



FROM MATERIAL WORLD

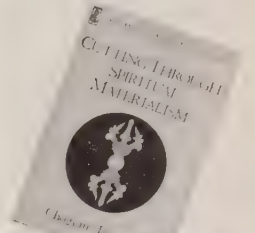

Cutting through Spiritual Materialism Chogyam Trungpa. 1973; 250 pp. \$14. Shambhala. **Material World: A Global Family Portrait** Peter Menzel. 1995; 255 pp. \$25. Sierra Club Books. **Stuff: The Secret Lives of Everyday Things** John C. Ryan and Alan Thein Durning. 1997; 86 pp. \$9.95. Northwest Environment Watch, 1402 Third Avenue, Seattle, WA 98101. 206/447-1880. www.speakeasy.org/new.

POSTSCRIPT: WHAT'S HAPPENED TO JB AND LIZ'S HIGHLY EVOLVED TOOLBOX SHOPTRUCK?

by J. BALDWIN



This toolbox commenced in 1949 with a lonely Sears hammer, and grew slowly, along with the experience of its builders and keepers. It has become a highly refined and capable collection, living up to my requirements as a design-solution-inspiring "Three-Dimensional Sketchpad." Installed in an unfolding walk-in van, the ton of tools and the compact space to work them in have gone where they're needed for more than twenty years. *Whole Earth* chronicled the adventure in Issues No. 5 and 9, and in the 1985 *Essential Whole Earth Catalog*. Always aiding and abetting evolution, the portable toolbox/shop is now virtually bigger and conceptually smaller.

It's serving as the local do-tank parked behind our chicken coop home. The only recent additions are a new Bosch battery drill and a cast-iron Delta scroll saw we needed to execute a complex scale model of a

barge-mounted Living Machine (see p. 33). The 1958 walk-in van part is a bit too venerable for highway use now, and tires are no longer available. It'll probably get left behind (minus the tools and benches) on our next move. That will be sad, but it brought tool capability to a variety of experiments going on around the USA in the sixties, seventies and eighties, just as it was designed to do. That need is pretty much gone with the wind. Sigh.

The old beast would still work fine in town; someday we'll probably sell it to a street act needing a portable stage with secret trapdoors. ∞

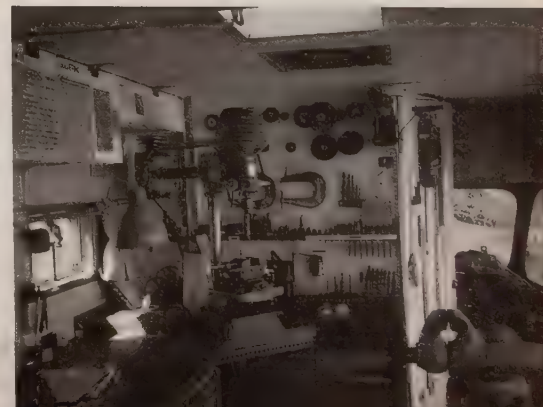

WILDERNESS & CIVILIZATION

NATURE AS SEEN FROM KITKITDIZZ IS NO "SOCIAL CONSTRUCTION"

by GARY SNYDER

Gary Snyder needs no introduction. Old friend of *Whole Earth* (he's on our editorial board); generous and stalwart bard in the legacy of Ezra Pound, Chinese and Japanese poetics, and oral story-telling; and speaker for bioregions, wilderness, wildness and Buddhist practice. This piece was written from Kitkitdizz (his home, named for its totemic plant) and first published in *Wild Earth* (see access). Recent academics have claimed terms are just sounds that humans provide with arbitrary meanings. So "wilderness" is not actual. Gary responds.



I must confess I'm getting a bit grumpy about the dumb arguments being put forth by high-paid intellectual types in which they are trying to knock Nature, knock the people who value Nature, and still come out smelling smart and progressive.

The idea of Nature as being a "social construction"—a shared cultural projection seen and shaped in the light of social values and priorities—if carried out to the full bright light of philosophy, would look like a subset of the world view best developed in Mahayana Buddhism or Advaita Vedanta, which declares (as just one part of its strategy) the universe to be maya, or illusion. In doing so the Asian philosophers are not saying that the universe is ontologically without some kind of reality. They are arguing that, across the board, our seeing of the world is a biological (based on the particular qualities of our species's body-mind), psychological (reflecting subjective projections), and cultural construction. And they go on to suggest how to examine one's own seeing so as to see the one who sees, and thus make seeing more accurate.



Heraclitus, the Stoics, the Buddhists, scientists, and your average alert older person all know that everything in this world is ephemeral and unpredictable. Even the earlier ecologists who worked with Clementsian succession theory knew this! Yet now a generation of resource biologists, inspired by the thin milk of Daniel Botkin's theorizing, are promoting what they think is a new paradigm that relegates the concept of climax to the dustheap of ideas. Surely none of the earlier scientific ecologists ever doubted that disturbances come and go. It looks like this particular bit of bullying also comes just in time to support the corporate clear-cutters and land developers. (Granted blow-downs, bugs, fires, and landslides, communities like the vast northern hemisphere trans-Pacific Sequoia Forests prior to the ice age lasted in essence for several million years.)

It's a real pity that the humanities and social sciences are finding it so difficult to handle the rise of "nature" as an intellectually serious territory. For all the talk of "the other" in everybody's theory these days, when confronted with a genuine Other, the non-human realm, the response of the come-lately anti-Nature intellectuals is to circle the wagons and declare that Nature is really part of Culture. Which may be just a strategy to keep the budget within their specialties.

A lot of this rhetoric, if translated into human politics, would be like saying "Black people are the social construction of whites." And then they might as well say that South Central Los Angeles is a problematic realm that has been exaggerated by some white liberals, a realm whose apparent moral issues are also illusory, and that the real exercise in regard to African Americans is a better understanding of how white writers and readers made them up. Of course, liberal critical theorists don't talk this way when it comes to fellow human being because they know what kind of heat they'd get. In the case of Nature, because they are still under the illusion that it isn't seriously there, they indulge themselves in this moral and political shallowness.

Conservationists and environmentalists have brought some of this on themselves. We still have not communicated well on the question of "Why value biodiversity?" Many if not most citizens are genuinely confused over why such importance appears to be placed on hitherto unheard-of owls or fish. Scientists have been heard from, but the writers and philosophers among us (me too) should speak our deep feelings for the value of the non-human with greater clarity. We need to be more creative, stay fresh, write clean prose, eschew obscurity, and not intentionally exaggerate. And we need to comprehend the pain and distress of displaced working people everywhere.

A wilderness is always a specific place, basically there for the local critters that live in it. In some cases a few humans will be living in it too. Such places are scarce and must be rigorously defended. Wild is the process that surrounds us all, self-organizing Nature: creating plant zones, humans and their societies, all of it ultimately resilient beyond our wildest imagination. Human societies create a variety of dreams, notions, and images as to the nature of Nature. But it's not impossible to get a pretty accurate picture of Nature with a little first-hand application—no big deal. I'd say take these dubious professors out for a walk, show them a bit of the passing ecosystem show, and maybe get them to help clean up a creek. ∞

The current use of the "social construction" terminology, however, cannot go deeper, because it is based on the logic of European science and the "enlightenment." This thought-pod, in pursuing some new kind of meta-narrative, has failed to cop to its own story—which is the same old occidental view of Nature as a realm of resources that has been handed over to humanity for its own use. As a spiritually (politically) fallen realm, this socially constructed nature finally has no reality other than the quantification provided by economists and resource managers. This is indeed the ultimate commodification of Nature, done by supposedly advanced theorists, who prove to be simply the high end of the "wise use" movement. Deconstruction, done with a compassionate heart and the intention of gaining wisdom, becomes the Mahayana Buddhist logical and philosophical exercise which plumbs to the bottom of deconstructing and comes back with compassion for all beings. Deconstruction without compassion is self-aggrandizement.

So we understand the point about wilderness being in one sense a cultural construct, and what isn't? What's more to the point, and what I fail to find in the writings of the anti-wilderness crowd, is the awareness that we are not into saving relatively uninhabited wild landscapes for the purpose of recreation or spirituality even, but to preserve home-space for non-human beings. And that this preservation of diversity is essential to planetary ecological, spiritual, and evolutionary health for all.

Some of these writers set up, and then attack, the notion of "pristine wilderness," and this again is beating a dead horse. It's well known that humans and proto-humans have lived virtually everywhere for hundreds of millennia. "Pristine" is only a relative term. But humanly-used as the landscape may have been, up until about ninety years ago the planet still had huge territories of wild terrain, which now are woefully shrunken. Much of the wild land was also the territory of indigenous cultures that fit well into what were inhabited wildernesses.

The attacks on Nature and wilderness from the ivory towers come at the right time to bolster the global developers, the resurgent timber companies (here in California, the Charles Hurwitz suits at Pacific Lumber), and those who would trash the Endangered Species Act. It looks like an unholy alliance of Capitalist Materialists and Marxist Idealists in an attack on the rural world that Marx reputedly found idiotic and boring. Yikes!



The Practice of the Wild. Gary Snyder. 1990; 190 pp. \$11. North Point Press. *Turtle Island*. Gary Snyder. 1974; 114 pp. \$8.95. W. W. Norton.



Walden and Essay on Civil Disobedience. Henry David Thoreau. 1854; 253 pp. 7.95. Princeton University Press. *Wild Earth*. Dave Foreman. Publisher. \$25/year (quarterly). PO Box 455, Richmond, VT 05477, 802/434-4077. *A Sand County Almanac*. Aldo Leopold. 1949; 295 pp. \$6.99. Ballantine Books. *The Diversity of Life*. Edward O. Wilson. 1992; 424 pp. \$14.95. W. W. Norton.





DIFFERING WITH DIGNITY

by JUDITH MARTIN, MISS MANNERS

Judith Martin's *nom de plume* is Miss Manners. Her book *Common Courtesy*, excerpted here, comes from lectures she gave at Harvard. In them, she unveils that the Miss Manners many thought to be simply a populist syndicated columnist and writer of etiquette books for the forelorn and confused is equally a remarkable historian, thinker, and stylist on American modes of behavior, class, and business. Being "civil" is stripped of the barbarity of civilization, and returned to the coffee cooler, baseball game, and household where it has most import. We thank her and her agent for allowing us to print this excerpt (copyright © 1985 by Judith Martin). To our horror, *Common Courtesy* is out of print.

The state of American etiquette is now worse than ever. Miss Manners is forced to act. I shall attempt to show what went wrong, and to propose a modest solution.

In do-your-own-thing America, there is no longer much distinction between etiquette, the rules of behavior, and manners, the social premises from which they are derived. As the latter are constantly undergoing revision, one can get into serious trouble merely by following the simplest habits of one's youth. A gentleman who thoughtlessly defers to a lady can find himself labeled a pig; a young person taught to address elders in terms of respect may be scolded for making them feel old.

There is also an unfortunate tendency to confuse manners, which pertain to the outer person, with morals, which belong in such interior realms as the conscience and the soul. Religions generally put regulations about eating, dress, and washing in the same category as opportunities for sinning that promise considerably more fun.

In Puritan America, acts forbidden by law included making nasty faces, jeering at others (or leering, depending on how attractive one found them), flirting, swearing, gossiping, and finger-sticking, a list practically constituting a catalogue of everything that makes life worth living.

I can understand the temptation of those who deal in both manners and morals, such as my colleague Cotton Mather and his friend God, to blur the distinction in order to be able to call out the moral militia for transgressions of manners. Threatening jail or hell is more effective and less wearing than the basic technique of those who merely teach manners, which is nagging.

However, the failure to distinguish between manners and morals also suggests, erroneously, that from personal virtue, acceptable social behavior will follow effortlessly. All you need is a good heart, and the rest will take care of itself. You don't ever have to write thank-you letters.

It is probably more sensible to hope that practicing proper behavior eventually encourages virtuous feeling; that if you have to write enough thank-you letters, you may actually come to feel a flicker of gratitude. "In truth," wrote Mr. Jefferson, "politeness is artificial good humor, it covers the natural want of it, and ends by rendering habitual a substitute nearly equivalent to the real virtue."

If not, good manners can at least put a decent cover over ugly feelings. Charming villains have always had a decided social advantage over well-meaning people who chew with their mouths open. "I could better eat with one who did not respect the truth or the laws," wrote Ralph Waldo Emerson, "than with a sloven and unrepresentable person."

The belief that natural behavior is beautiful, and that civilization's restrictions spoil the essential goodness inherent in all of us noble savages, is, of course, the Jean Jacques Rousseau School of Etiquette. He began his career as a footman, and does not seem to have cared for it.

A major influence in Jefferson's time, Rousseau's philosophy continues to survive in the pop-psychology and "human potential" movements of today, and in the do-nothing school of child-rearing, which has given us so many little—savages. In point of fact, we are all born rude. No infant has ever appeared yet with the grace to understand how inconsiderate it is to disturb others in the middle of the night.

The concept that civilization is inherently corrupt, but Nature inevitably benign, is particularly popular in earthquake- and flood-ridden California. The natural approach to human relations presumes that to know any person well enough is to love him, and that, therefore, the only human problem is a communication problem. It refuses to admit the possibility that people might be separated by basic, deeply held, genuinely irreconcilable differences—philosophical, political, or religious.

Thus, the effort to trivialize etiquette as being a barrier to the happy mingling of souls, actually trivializes intellectual, emotional, and spiritual convictions by characterizing any difference between one person's and another's as no more than a simple misunderstanding, easily solved by frank exchanges or orchestrated "encounters."

Many forms of etiquette are employed exactly to disguise those antipathies that arise from irreconcilable differences, in order to prevent mayhem. When I was president of a school board, a member with whom I disagreed on every possible educational issue suggested that we could resolve our differences if the trustees all went off on retreat and got to know one another better. "You don't understand," I had to tell him. "The only reason I haven't murdered you is that I really don't know you all that well, so I feel I have to give you the benefit of the doubt. Do you want to remove that doubt?" The reason that diplomacy is so stilted is that its purpose is to head off the most natural social relation between countries in economic or ideological conflict, namely war.

The charge is often made against etiquette that it is artificial. Yes, indeed, it is. Civilization is artificial. When people extoll the virtues of naturalness, honesty, informality, intimacy,

and creativity—watch out. Honesty has come to mean the privilege of insulting you to your face without expecting redress, and creativity that it is wrong to interfere with a child who is destroying your possessions. It is apparently natural behavior to treat the sick, the disabled, and the bereaved with curiosity and distaste, but it is also highly uncivilized.

We need a coherent code of manners. I would prefer ratings based not on commerce—dictated expenditure but on gentility of manners. We seem to be gradually adopting a system of precedence based on age, rather than gender, and I rather think that is a good idea, as it gives everyone a shot at being last and then first.

I believe that the only hope for satisfying the American idea of equality of treatment in this society—being recognized as "being as good as anyone else"—is reestablishing the dualism of the commercial and the personal realms. By not separating trade and society in the lives of individuals, we force people to take total identity from their jobs, and therefore rob them of any realm in which human beings could and should have full equality in our society.

One should not be assigned one's identity in society by the job slot one happens to fill. If we truly believe in the dignity of labor, any task can be performed with equal pride because none can demean the basic dignity of a human being.

Off the job, there will be many attributes that may make one person more successful than another, but these will be ones to which anyone can aspire, and which, in the absence of an objective ranking system, such as prevails in the business realm, different people will judge in different ways. I believe and hope that a revival of the private realm would preclude hierarchies in which absolute standards, such as job titles and money, rather than personal qualities, mark some individuals as obviously superior to others.

I think my colleague Thomas Jefferson would agree. I'm not so sure about my colleague Cotton Mather. ∞



Dear Miss Manners: Is Sophia Loren showing good manners in considering Jayne Mansfield's dress? Perplexed. Whole Earth Staff.



WISE, LIKEWISE, and OTHERWISE

The Gift: The Form and Reason for Exchange in Archaic Societies. Marcel Mauss and W.D. Halls, translator. 1990; 164 pp. \$9.95. W.W. Norton. **Miss Manners' Guide for the Turn-of-Millennium.** Judith Martin. 1990; 742 pp. \$17. Simon & Schuster.

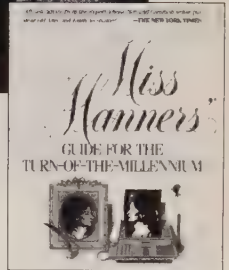
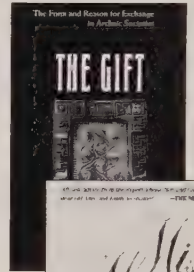

Democracy in America. Alexis De Tocqueville. 1969; 778 pp. \$20. HarperCollins. **The Rise of the West: A History of the Human Community.** William McNeill. 1963; 860 pp. 22.95. University of Chicago Press. **A History of Civilizations.** Fernand Braudel. 1987; 600 pp. \$15.95. Penguin.

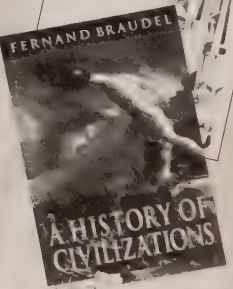
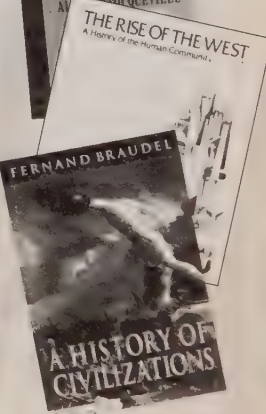
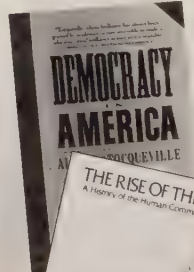

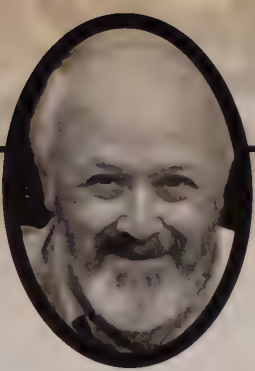

TO MAKE SURE THAT THINGS GO ON

by WILLIAM H. CALVIN

Bill Calvin has been a foremost thinker in applying Darwinian principles to the anatomical level of the human organism. His moniker—*theoretical neurophysiologist*—hardly reflects his breadth of scholarship. He writes on climate change, on early methods of predicting eclipses, ecology, internal voice generation, intelligence... His most recent book *The Cerebral Code: Thinking a Thought in the Mosaics of Mind* (see access p. 5) discusses, among other things, brain matter as a commons.

The Red Queen told Alice that, in Wonderland, you had to run, just in order to stay in the same place. This treadmill seems to have shifted gears in the three decades since the first Whole Earth Catalog, making versatility and foresight even more important. Extrapolate another three decades ahead, to 2030, and the gears may have shifted yet again.

The big problem with speed is that reaction time doesn't increase to match; indeed, it doesn't speed up much at all, except via foresight. When things speed up, you don't have time to simply feel your way into the new situation and do feedback corrections. So anticipation becomes far more important: you now need elaborate tentative plans, compared to when the pace of change was slower and gentler, just to be able to choose the right path as the fog briefly clears. That means you need a spread of plans, an ability to imagine various contingencies.

Foresight is part of a suite of "higher intellectual functions" (including structured language, planning ahead, multistage logical inference, a fondness for games with arbitrary rules, and music) that evolved sometime in the last five million years, since we last shared an ancestor with the chimpanzees and bonobos. It made ethics possible—but also warfare (the big difference between raiding and warfare is stockpiling supplies).

To offer one example: foresight may enable us to head off the consequences of potentially catastrophic climate change, both that caused by industrialization and that which is "natural" but threatening to civilization. One of the big scientific surprises has been the recent realization that climate change sometimes speeds



up. We now know that our ancestors suffered from a series of whiplash climate changes over the last million years or so, ones so abrupt that, within a single generation's lifetime, it was a whole new environment, worldwide. Imagine daytime temperatures becoming more like nighttime temperatures, even in the tropics. These abrupt coolings happen, not because the sun is flicking like an old fluorescent light tube, but because ocean currents rearrange themselves so that the Gulf Stream doesn't warm Europe—and Europe reverts to being more Canadian in climate. Europe's agriculture would no longer be able to feed twenty-three times as many people as Canada's, and the rest of the world wouldn't be much better off, as such abrupt coolings affect most of the inhabited portions of the globe. It takes little imagination to picture a series of wars over dwindling resources as the human population crashes and our civilization disintegrates.

Though it's been 8,000 years since the last abrupt cooling, they usually happen every several thousand years, each lasting for centuries before an equally abrupt rewarming. Some have been associated with instabilities in the ice sheets that covered Canada and

Scandinavia. But it is clear that they can happen even in situations like today's; indeed, our gradual global warming could trigger an abrupt cooling in several different ways. Imagine taking a shower where the water is gradually warming up—but then someone starts the laundry and the shower turns abruptly cold. They don't balance out.

A little foresight may well be able to prevent the earth's abrupt coolings, "natural" though they have been. While combating global warming is obviously high on the agenda, the physical principles involved in the abrupt rearrangements needed to prevent abrupt cooling are very simple. Giant whirlpools in the Labrador and Greenland Seas flush cold water—that has already given up its heat to Canadian air bound for Europe—from the surface to the ocean depths, thus making way for more warm water to flow north. When enough of these whirlpools fail, the climate abruptly cools. Technological boosters for the whirlpools could head off failures.

Waiting until it starts to happen will be too late. The failure has typically occurred in just a few years. So clearly it's a matter of heading it off, not handling it on the fly. But can society move quickly enough, given its usual slow reaction times when building an international political consensus is involved? Foresight isn't enough. You also need the initiative to make preemptive moves to head off some of the developments that foresight warns you about. An abrupt cooling won't be the end of humanity, but it would kill billions and destroy much of what we call civilization. To head off catastrophic backsliding will require some preventive climate medicine. ∞

State of the World: A Worldwatch Institute Report on Progress Toward a Sustainable Society. Lester R. Brown and Christopher Flavin. 1998 (yearly); 251 pp. \$13.95. W.W. Norton/Worldwatch Institute, 1776 Massachusetts Avenue, NW, Washington, DC 20036, 202/452-1999, www.worldwatch.org. **Vital Signs 1998.** Lester R. Brown and Christopher Flavin. 1998 (yearly); 207 pp. \$12. W.W. Norton/Worldwatch Institute, 1776 Massachusetts Avenue, NW, Washington, DC 20036, 202/452-1999, www.worldwatch.org. **The New State of the World Atlas.** Michael Kidron and Ronald Segal. Out of print.



The Columbian Exchange: Biological and Cultural Consequences of 1492. Alfred W. Crosby, Jr. 1972; 268 pp. \$13.95. Greenwood Publishing Group, 88 Post Road West, Westport, CT 06881, 203/226-3571. **The Population Bomb.** Paul R. Ehrlich. 1968; 211 pp. \$25.95 (\$30.90 post-paid). Buccaneer, PO Box 168, Cutchogue, NY 11935, 516/734-5724. **Maybe One: A Personal and Environmental Argument for Single-Child Families.** Bill McKibben. 1998; 254 pp. \$23. Simon & Schuster.

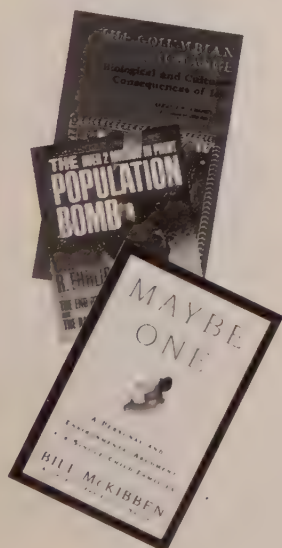

GLOBAL ANXIETIES

1. POPULATION GROWTH
2. WATER/SOIL DEPLETION—FOOD AND FAMINE
3. SPECIES/HABITAT HOLOCAUST
4. HUMAN HEALTH: ENVIRONMENTAL POISONS, NEW DISEASES
5. CLIMATE CHANGE
6. INFRASTRUCTURE COLLAPSE
7. WARS



Growth of World Population in Millions, 1000 CE to 2000 CE.





WHITHERING POLITICS?

by **JAY KINNEY**

Jay Kinney is presently editor of *Gnosis* and formerly an editor of *CoEvolution Quarterly* and *Whole Earth Review*. He is the person we search out when it comes to fringe groups or a Big Picture view of the political spectrum. If he had time, we'd ask him to draw more cartoons.

I'd like to propose something radical: maybe, just maybe, most conservatives and liberals, leftists and rightists are well-intentioned people sincerely looking to improve things. This throws a monkeywrench in the works as far as political loyalties go, since one's opponents are brutes and scoundrels who are misguided at best and more likely nasty and evil. But let's suppose they aren't. Where does this take us?

For starters, it brings up another unsettling proposition: both sides of the fence may have valuable insights as well as mistaken assumptions. It encourages us to extricate ourselves from pat ideological battles and consider alternatives beyond options A or B. This is attractive because neither full-bore communism nor so-called democratic capitalism has worked terribly well.

Communism imploded a decade ago, destabilized by its own contradictions and its inability to provide enough desirable consumer goods. Meanwhile, deregulated capitalism has an uncanny knack for consolidation leading to monopolization (witness recent moves in telecommunications and banking) and the liberal democracies are hobbled by voter apathy and elite manipulation. In sum, it's a case of either too few color TVs or too many. Both the left and right have tended to focus on material solutions to an essentially spiritual dilemma: what can bring us happiness in a world stripped of any sense of harmony or integration?

A third approach has been in the air for quite some time, with valiant stabs made by the Greens, bioregionalists, and Fourth World activists who've opted out of the bi-polar tennis match. They've brought the environment into the political debate and started sifting through the ideological ashes. But leave it to those grand opportunists, Bill Clinton and Tony Blair, to invoke the rhetoric of a new "Third Way" as a kind of pro-active centrism which amounts to lukewarm social democrats scraping the bibs of their Wall Street siblings and offering the scraps to the disadvantaged kids next door. If we don't watch out we may get the same old stuff repackaged as an antidote to itself.

Why is it so hard to even conceptualize a truly alternative politics? The pundits, policy wonks, and activists, our political protectors, have a vested interest in keeping things within familiar bounds. They know which side their bread is buttered on, and escaping the left/right treadmill can be truly scary. The last time any serious alternative to our familiar political ruts was tried out, it involved brown shirts and übermenschen and maximum leaders who left half of Europe in smoking ruins. No one wants to go out on that limb again.

The good news is that there are signs of non-aligned alternative politics coalescing from the bottom up. Two current examples are

Democracy Unlimited of Humboldt County (DUHC) in California, and the node of activity developing around the renegade political philosopher Richard K. Moore. Both defy traditional left/right pigeonholes and speak to concerned activists across the political spectrum. They are analyzing the present malaise, networking with other grassroots groups, and identifying practical arenas where small changes can begin to be made.

DUHC emphasizes the economic and social roles corporations have played since their creation as legal entities in the eighteenth century. Has our democratic framework been distorted by corporate entities that are treated by the law as persons yet whose directors are exempt from direct responsibility? How has corporations' ability to last in perpetuity affected the distribution of economic resources and power? These questions are intriguing because their answers are not immediately self-evident.

Richard K. Moore, a retired Silicon Valley software engineer living in Ireland who now devotes his time to socio-economic inquiry, is the most provoking non-orthodox theorist at work today. Moore focuses on how the process of economic and political globalization is rapidly evolving to benefit transnational corporations and allied elites as it dismantles the sovereignty of nation states. He identifies an authoritarian impulse in the steady erosion of civil liberties, privacy, human-scale enterprises, and democratic participation, a kind of "stealth fascism" ripening under the guise of anti-terrorism and the drug war. This, no doubt, sounds extreme and paranoid, but Moore's reasoned analysis avoids most of the pitfalls found in the conspiracy theories retailed by the John Birch Society or the Montana Militia.

As befits the late nineties, both DUHC and Moore's materials are readily available on the Web. Moore has a very active email discussion list where a remarkably varied network of activists refines his theories and puts them to the test. Only time will tell whether these fledgling groups carry the seeds of a wider political movement to come or whether the steamroller of history will run them over. My hunch is that if people of good will from both the left and right can find sufficient common ground to work together towards changes that both agree upon, things could really start rocking. ☞

Democracy Unlimited of Humboldt County
PO Box 27, Arcata, CA 95518
<http://www.monitor.net/democracyunlimited>

Citizens for a Democratic Renaissance (Moore's networking organization)
c/o Jan Slakov
PO Box 35, Weymouth, NS
Canada BoW 3To
<http://cyberjournal.org>

Getting to Yes: Negotiating Agreement Without Giving In. Roger Fisher and William Ury. 2nd edition, 1991; 187 pp. \$12.95. Houghton Mifflin. **The Ends of the Earth: From Togo to Turkmenistan, from Iran to Cambodia, a Journey to the Frontiers of Anarchy.** Robert D. Kaplan. 1997; 476 pp. \$15. Random House. **Silent Spring.** Rachel Carson. 1962; 304 pp. \$13. Houghton Mifflin. **And The Band Played On: Politics, People, and the AIDS Epidemic.** Randy Shilts. 1988; 640 pp. \$16.95. Penguin. **The Eleventh Plague: The Politics of Biological and Chemical Warfare.** Leonard A. Cole. 1997; 284 pp. \$14.95. W.H. Freeman. **Genetics and the Manipulation of Life: The Forgotten Factor of Context.** Craig Holdrege. 1996; 176 pp. \$14.95. Lindisfarne Books, 3390 Route 9, Hudson, NY 12534, 518/851-9155. **The Mountain People.** Colin M. Turnbull. 1972; 309 pp. \$12. Simon & Schuster.

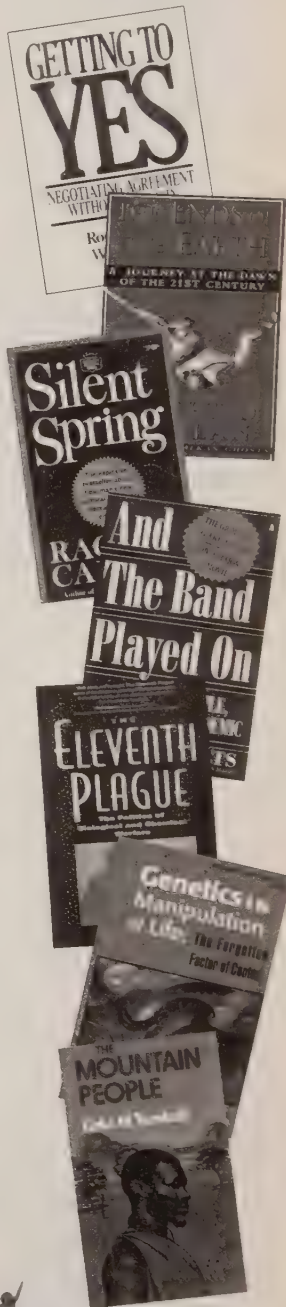

Income of Richest Fifth of Population Compared with Poorest Fifth, 1980-87 Multiples.

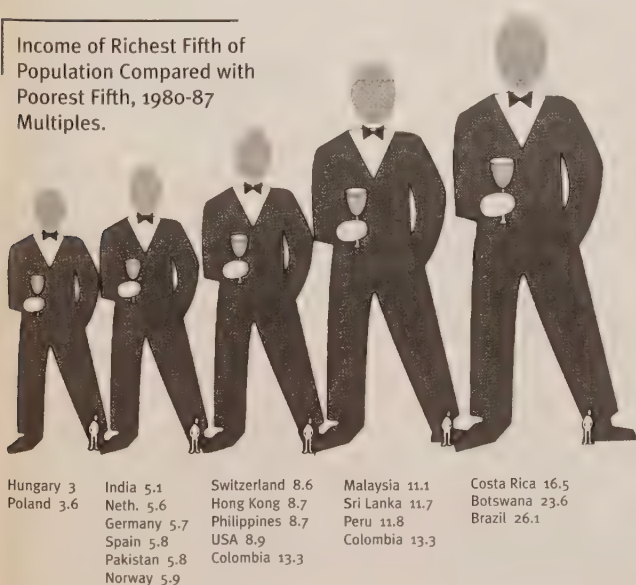

Top Ten Military and Paramilitary Forces, in Millions, 1980.

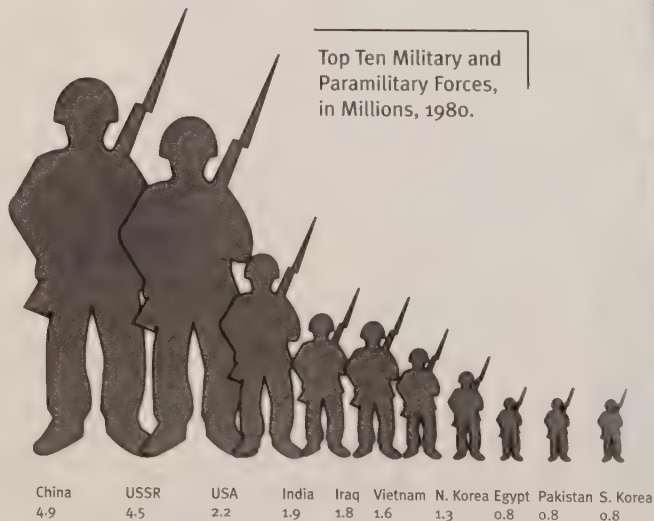



INTERNET: THE ILLUSION OF EMPOWERMENT

by JERRY MANDER

Jerry Mander knows best how to stir things up and change mass thinking. He is a Senior Fellow at the Public Media Center, which runs full-page ads and creates media packets for groups with good causes. He's program director of the Foundation for Deep Ecology and acting chair of the International Forum on Globalization. His books have made a difference: *Four Arguments for the Elimination of Television* (which first appeared in our magazine), *In The Absence of the Sacred: The Failure of Technology and the Survival of Indian Nations*, and *The Case Against the Global Economy* (co-edited with Edward Goldsmith). Jerry's on our editorial board.

Congratulations to Whole Earth for surviving so long, for turning away from technotopian visions, and for returning to community, ecological sustainability, individual empowerment. It is truly a revolutionary act when people or institutions are able to say, "My God, we're out on the wrong limb here; we are not heading where we meant to; let's get grounded."

And as we attempt to regroup—which is to say, reconnect with an Earth-based reality that is *not* virtual—we all need to sweep around in the corners of our consciousness to examine some basic assumptions. The one I'm most interested in changing has to do with the issue of "empowerment," specifically the idea that the computer revolution contributes to it. I think the opposite is the case: computers are *disempowering* us, and our causes, and are leading to the highest degree of corporate-controlled centralization in history. Computers, the global information networks, and the "information society" empower *them*, not us.

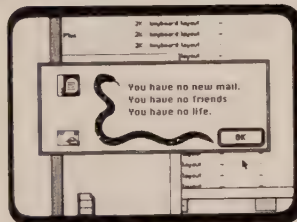

The computer revolution is a weird

one since both sides seem to agree about it. They all think it's great. The corporations and the activists, the engineers and the artists, the Al Gores and the Newt Gingriches, the conservatives and the liberals all outdo themselves to articulate utopian visions of a computer-based society. Does that make you uneasy? Is Newt Gingrich's utopia the same as yours? In any case, shouldn't we have learned by now to be wary of any "revolution" led by corporations and vice presidents?

Even my own friends tend to side with the computers-bring-you-power argument. "You miss the point," they tell me. "Computers can help us communicate with like-minded types; we can get better organized against those big corporations. We can reach people all over the planet, and use email to mobilize."

Some of my friends quote Kevin Kelly, formerly of Whole Earth and now of *Wired*. He argues that the computer revolution created a new political structure on the planet. The symbol of today should no longer be the atom, he has written, now it's the web, or the net. According to his view, the political center has been wiped out and an entirely new web structure "elevates the power of the small player," while promoting heterogeneity and a new kind of pure democracy where we can be

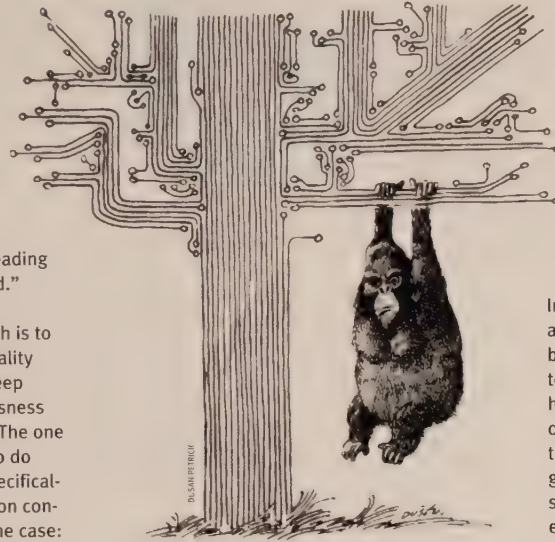

equal players in the global information game. Also, it brings on a new "incipient technospiritualism."

Kevin's right on the last point: technospiritualism, though I favor the older kind that doesn't require mediation by machines. As for the idea that the old political center has been wiped out by our PCs and email, and that web politics has brought us a computer-enhanced democracy, let me ask this: Shouldn't we call it "virtual democracy"? I think so. Because somebody forgot to tell the transnational corporations in Tokyo, New York, Brussels, and Geneva that the real power was no longer in the center, that it was now out of their control. Two hundred corporations now control twenty-eight percent of global economic activity; twenty-four corporations are among the hundred largest economies of the world, far larger than many countries. The computer has had a crucial role to play in this, as have the big new global trade agreements, which have *deregulated* all controls on international banking, investment, and capital movement. Corporations are now free to use the new global technologies to move their assets around the world, instantaneously, at the touch of a key, without the ability of nation-states to observe, control, or slow them down.

Some people understand this, notably among the right wing. Dr. Joe Cobb of the Heritage Foundation once told me that because of technology, corporate-led globalization is "inevitable." It can't be stopped (presumably because technology itself "can't be stopped," yet one more paradigm worth examining).

So, what kind of revolution do we have here? To use terms like "empowerment" to summarize the effects of computers is to badly misrepresent what power is about in a real political

and economic context. Computers may help individuals feel powerful or competent and surely they are useful; nobody denies this. But this does nothing whatever to balance the ultimate drift of the technology, to help gather staggering new power in the hands of giant corporations, banks, and global trade bureaucracies, all made possible by these same instruments.

In my view, computer technology will eventually be understood by all of us, as it already is by the right wing, as the greatest centralizing technology ever invented. For while we sit happily at our PCs editing our copy, sending our emails, designing our little web pages, transnational corporations are using their global networks twenty-four hours a day, at a scale and a speed that makes our level of empowerment seem pathetic by comparison. The giant transnationals of today simply could not exist without the global computer networks. When *they* push their computer keys, they cause hundreds of billions of dollars in resources to move from, say, a bank in Geneva to Sarawak, resulting in a forest cut down. Or else they push a key and buy billions of dollars of a national currency, only to sell it again a few hours later, leaving countries' economies in shambles, and populations devastated. *That* is information with power. Information by itself is for the disempowered; and the Internet is our opiate.

The question we have to learn to ask about new technology is *not* whether it benefits *us*, but whom does it benefit most? For despite its usefulness to us in many activities, the electronic revolution has far more to offer the largest enterprises on the planet than it does to you and me; we suffer a net loss from its emergence as the new global nervous system.

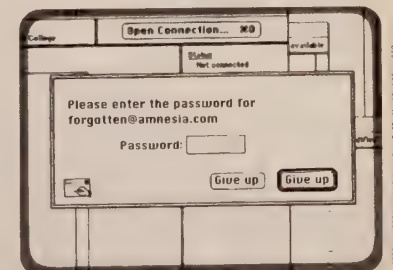

If you want to use your computers for your various good works, okay. But please keep in the forefront of your minds who else is using this wonderful "decentralizing" instrument, to what ends and with what results. *And let's stop calling them empowering.* ∞

The Case Against the Global Economy. Jerry Mander and Edward Goldsmith, eds. 1996; 560 pp. \$16. Sierra Club Books. **For the Common Good: Redirecting the Economy Toward Community, the Environment, and a Sustainable Future.** Herman E. Daly and John B. Cobb, Jr. 2nd edition, 1994; 534 pp. \$18. Beacon Press. **The End of Work: The Decline of the Global Labor Force and the Dawn of the Post-Market Era.** Jeremy Rifkin. 1995; 350 pp. \$15.95. G.P. Putnam's Sons.

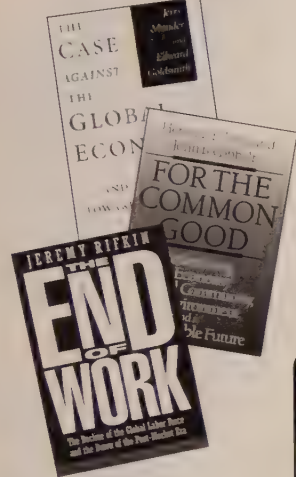

IFG News. \$25 membership includes twice-yearly newsletter. International Forum on Globalization, 1555 Pacific Avenue, San Francisco, CA 94109, 415/775-3394. www.ifg.org. **Finance & Development.** Free (quarterly). International Development Fund and The World Bank, 700 19th Street, NW, Washington, DC 20431, 202/623-8300. www.worldbank.org/fandd. **The Economist.** \$125/year (51 issues). PO Box 58524, Boulder, CO 80322-8524, 303/604-1464. www.economist.com.



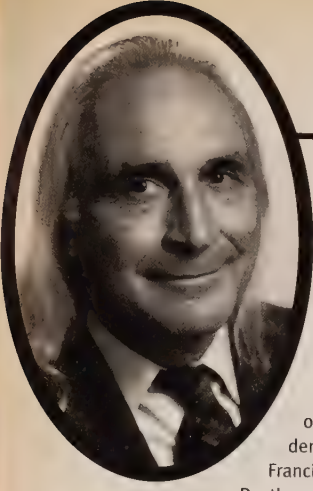

KGB-ING AMERICA

by TONY SERRA

Tony Serra has spent his professional life trying to insure that the law is applied as fairly to outcasts as to mainstream Americans. Hooty Croy, for instance, was an American Indian who was on death row when Tony took over his case. Croy was then acquitted at a second trial. Tony defended Huey Newton of the Black Panthers, the Hell's Angels, and Russell Little of the Symbionese Liberation Army. He has doggedly fought to insure that punishments truly fit the crime and do not become excessive political tools of repression. He is perhaps best known as the warrior lawyer defending citizens charged with marijuana possession or dealing. One of the most formidable trial lawyers of the century, Tony defends the independence of the judiciary in this phone interview.

The late sixties, when I started practice, were marked by a great number of salient political causes, embodied in demonstrations in Berkeley and San Francisco. I came to represent the White Panthers, the Black Panthers, the Symbionese Liberation Army, and a number of other groups like the New Liberation Front. I confronted a phenomenon then which we hoped would diminish, but which has instead increased steadfastly. I'll call that phenomenon "The Secret Police Motif: Orwellian Prophecy Fulfilled," or "The KGB-ing of America."

INFORMANTS

In every criminal case in our alleged system of justice, some form of spy mentality is now present. There are degrees of informants. We probably have more nomenclature for informants than does any other culture. We have citizen informants, confidential informants, confidential reliable informants, unnamed anonymous informants, informants who are precipient, informants who are participatory, informants who are merely eyewitnesses, informants who are co-defendants, informants who precipitate charges by reverse stings. We are confronting informants and cooperating witnesses at every level: preliminary hearings, grand juries, and state and federal jury trials. Our system of justice is permeated by the witness or the provocateur who is paid by government for a role in either revealing or instigating crime. It's probably the greatest tragedy of my career, in terms of whether or not justice is really pursued and whether truth is a foundation for actualizing justice.

I reason: if the defense went out and bought witnesses—paid \$10,000 for one witness, \$20,000 for another, and \$50,000 for another for their testimony—it would be laughable from a jury's point of view. They would soundly reject that type of witness; we would be called obstruction-of-justice defendants and the lawyers would be prosecuted. Obviously, you can't do that. On the other hand, in every major case the informant or cooperating witness gets something far more precious than money; they get liberty. They get twenty years or ten years knocked off their sentences. They get to settle in a new lifestyle with a new identity and obtain a job or relocation in the federal or state witness protection program. The government is paying their witnesses with freedom. The witnesses have to deliver what the government wants or they don't get that bargain. As a consequence, the courts are rife with false testimony; every case is polluted by informants. The adversary system is tainted because everyone rolls or becomes a government witness and therefore there is no opposition. Constitutional rights aren't litigated because cases are determined by how much evidence an informant or corroborating witness can give you. At every level, independent judiciary is eroding.

It's something we confront every day. People in the subculture experience paranoia because they never know who's a spy or an informant. There's paranoia in the court system because you never know whether your codefendant is recording you. There's paranoia among the lawyers because you never know whether your client is rolling behind your back and recording you. In my opinion, the singularly most unexpected and singularly most devastating aspect of our system of criminal jurisprudence is the use of the informant.

THE GRAND JURY

Back in the sixties, the government utilized the grand jury to some small degree. Today, every federal case—99.9 percent of all federal cases—involves indictment by grand jury. That means no preliminary hearing, no discovery prior to indictment, no confrontation, no lawyer present on behalf of the accused. The accused isn't there, and doesn't see, hear, confront, or cross-examine his or her accusers. The grand jury system by its nature is secretive; it is considered a felony to reveal anything that occurred or what your testimony was.

We have a kind of misplaced historical procedure. We inherited the grand jury from English Common Law, where they used it to go after the lords and persons who were otherwise above the law. In a sense it was needed and justified then. But in our country, it is used now as an instrument of terror. Everyone fears it. You have relatives testifying against one another. With no confidentiality privilege with respect to family members other than husbands and wives, you have parents called to testify against their children. Children are called to testify against their

parents, and brother against sister, and so on. It lacks all due process. It is immoral. It is an instrument of oppression. It's another secret tool of an expanding executive branch.

MANDATORY SENTENCING

"Three strikes" types of penal laws are prevalent both in federal and state jurisdictions. Beyond that, in most federal cases, at least in drug cases, but spilling over into other arenas, the sentence is really set by the legislative process and by the executive—that is, the law enforcement agencies. They mandate what sentence is going to occur by how they file charges. The judiciary lacks power or discretion to vary much, if at all, from the mandatory sentencing and its attendant guidelines. You have a fatal shrinking of the balance of powers. We're all taught that our constitutional form of government works because of its tripartite system: executive, legislative, judicial. When mandatory sentencing occurs, the legislative, actualized by the executive, has swallowed up the judiciary. We do not have an independent judiciary. We have a rubber-stamp judiciary.

We never anticipated in the sixties that one-third of the adult black population in the United States of America would be either in custody or on probation or parole. We have eliminated a whole generation of blacks by incarcerating the youth; the ugly head of racism appears both as built in—implied conditions in the law itself—and in how people are charged. So you have a revisitation of something that we thought was eliminated in the sixties: the weakening of the judiciary as an independent body, and the recurrence of racism wedded to mandatory sentences that lock people away for inordinate periods of time.

We all know the platitude that our country presently has more people in jails or prisons than any other country in the history of the world. That was unpredictable in the sixties. We thought things were getting better. We thought that more freedom was going to occur, more understanding, more compassion, more brotherhood and sisterhood, more actualization of constitutional rights, a more equal division of resources. Those motifs of the sixties have been sadly aborted. What we have instead is approaching a police state that is investigated by undercover officers and informants, with judges' hands tied and prosecutors obtaining prison sentences that we could never have conceived.

BAIL

The notion of bail is vastly eroding. We have a concept now built into the law called "preventative detention," a euphemism that probably only totalitarian states could create. But what that means is that in most major cases, there's a presumption against bail. They don't have to give you bail. We're taught as children that in anything other than a capital offense, reasonable bail must be afforded. A presumption of innocence underlies our system of criminal jurisprudence; we have a strong history of not holding people in custody until their guilt or innocence has been determined. That's not true any more. Right now, the custodial status in preconvicted sentences—people who have not yet been sentenced—is astronomical and the jails are filled not only with convicted people, but with unconvicted people. We think that there are laws that establish rights to a speedy trial. In both federal and state cases, people languish in custody one or two years awaiting trial. It's what I'll call another plot, an agony visited upon criminal justice. In the sixties, we were naive, we were optimistic, and we believed that reform and new and enlightened ideas would ventilate through the judicial system. Instead, in most areas, the system has clamped down.

Some of us are crying out. The legal profession cries out like the miner's canary. We're saying, "The government is too strong. Beware!" "We're losing constitutional rights daily. Beware!" "The jury system is being poisoned by propaganda. They're not fair and impartial any more. Beware!" "Racism is creeping back into our system of justice. Beware!"

We hope that if we at least keep an eye on the situation and report it in a dramatic fashion, then another generation may do what we thought we were doing in the sixties, and swing the pendulum back. Because if the pendulum doesn't swing—judicially and court-wise—we are approaching a totalitarian state never before experienced in this country. ∞

Manufacturing Consent: The Political Economy of the Mass Media. Edward S. Herman and Noam Chomsky. 1988; 412 pp. \$17. Pantheon Books. **Kurdistan: In the Shadow of History.** Susan Meiselas. 1997; 388 pp. \$100. Random House.

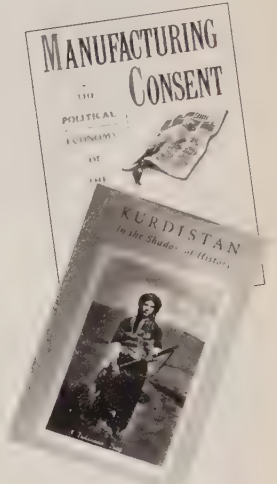

Turkish woman on trial for aiding the Kurdish struggle

The Commanding Heights. Daniel Yergin. 1998; 457 pp. \$26. Simon & Schuster. **The Economics of Money, Banking, and Financial Markets.** Frederick S. Mishkin. 1998; 732 pp. \$71.25. Addison-Wesley. **Post-Capitalist Society.** Peter F. Drucker. 1993; 232 pp. \$13.50. HarperBusiness.

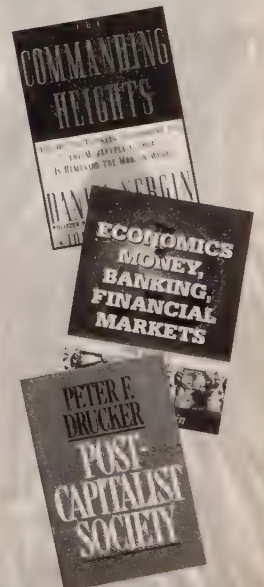

SOFTENING THE INTRACTABLE: TIBET, CHINA, AND ETHICAL PRESSURE

by ORVILLE SCHELL

I first knew Orville as an elected official in a small Northern California town. He then wrote *The Town That Fought To Save Itself*, and went on to become local co-owner of Niman-Schell Beef (about as fine an Angus operation as there is). He wrote an early book about the poisonous nature of the feedlot/stock raising business. Orville first went to China in 1971, speaks Chinese, and has written a half dozen books on China. He's now Dean of the School of Journalism at UC Berkeley, often interviewed on NPR, and at work on a book about American views of Tibet. Few combine experience and writing as simply and elegantly. The essay is part of a longer phone-taped interview.

The prospects for Tibet entirely depend on how things go in China. China has been very obdurate, emphasizing the reunification of what they view as the motherland, which is really the previous dynastic aggregation of Han Central Chinese with Manchus, Mongols, Muslims in the west, and Tibetans. This is the last part of the Revolution's program not yet repudiated, and the part that speaks to Chinese nationalism, pride, and the regaining of its territorial sovereignty. So China is not in a very charitable mood when it comes to independence movements and even movements towards autonomy. In Chinese leadership circles, these issues just do not play very well.

International protest presents a paradox. On the one hand, it certainly pushes China and reminds it that the world is watching. China needs to gain that kind of consciousness about what it's doing. It can't just do what it wants. It's been isolated for so long, it's gotten into some very refractory habits. On the other hand, it also inflames the situation because it links the Tibetan question up with what the Chinese view as outside interference, further abridgments of its sovereignty. So, at the same time that it helps, it also hinders. It creates a very difficult situation for anyone seeking resolution.

The Tibet/China question has been absolutely intractable, and it will remain intractable until it ceases being intractable; and that moment will come when the leadership in Beijing—when somebody or somebodies—decide that there's mileage in resolving this issue because it's giving China too bad a reputation in the world at large. As I've said earlier, it doesn't play in leadership circles yet because anybody who seems soft on the issue of Tibetan independence or autonomy, anyone in the leadership, risks being accused of being virtually traitorous.

The Dalai Lama has bent over backwards to the point of practically falling over to try to make every concession he can without in effect immolating his own cause. But there's a limit to what one side can do; like a bad marriage, if one partner makes all the concessions, the other very easily becomes accustomed to assuming that resolution is only on the side and in the hands of the other person.

Some Tibetans are hopeful that the Dalai Lama's concessions will lead to some sort of reconciliation. Other Tibetans are quite angry. They view their cause of independence as being compromised by any acknowledgments of Chinese sovereignty in exchange for the Dalai Lama returning back home and saving Tibetan culture. So it's a very, very perilous edge that the Dalai Lama has to walk on.

Most Chinese, whether in Tibet or outside Tibet have a rather simple view of things. They are very much victims of their own propaganda: they view Tibet as theirs. It is one of the great tragedies of a press that is not free that they have very little association with the notion of ethnic self-determination or other versions of Sino-Tibetan relations. It's a very complicated subject; the Chinese tend to be rather one-dimensional in their views of Tibet.

Recently there's been a very large, economically based migration of Han Chinese into Tibet. Tibet is in effect now gaining an actual market economy, rather than just a barter economy, and this is almost exclusively being run by Chinese. I think the attitude of most Tibetans is that the Chinese are colonials. Migration has brought some intermarriage, which tends to be difficult. In general, for Tibetans to get ahead, they basically have to learn Chinese and do long stints in China, and in a certain kind of very self-defeating sense, deny their own language, heritage, and ethnic ties.

The Chinese may be waiting for the Dalai Lama to die, and, after that happens, then the exile movement won't really have any figurehead around whom to coalesce. I think the situation will become more violent. The Chinese overlook the enormous potential to avoid violence should the Dalai Lama return to Tibet. It is incipiently quite a violent situation; there is enormous frustration, and should he die, I think there may be some huge upwelling of very frustrated sentiment. It's a kind of typical myopic Chinese view that the best way to manage a situation is to control it, to try to

manipulate and stifle it, rather than to creatively use the various forces at hand in an imaginative and positive way.

I am not particularly hopeful, but I'm also mindful that there could come a time—and it will probably come very quickly—when someone in China will decide that it's time to reverse the verdict on the Beijing massacre of 1989, reverse the verdict on the famine that killed thirty million people in the early sixties, reverse the verdict on Tibet, and find some new angle of repose. It's not a difficult problem to solve. It's only difficult to solve from the perspective of Chinese sensitivities over sovereignty, and encroachment and all. The solution will only come when China gets a much more imaginative and independent-minded leader, someone who says, "Listen, this is absurd, China has suffered too much. The slings and arrows of world opinion are unnecessarily against us. There's much to be gained and little to be lost by resolving the Tibet situation in a way satisfactory for everyone." They couldn't have a more reasonable and cooperative partner than the Dalai Lama. I mean, God knows, Tibet's leader could be a Saddam Hussein or someone like that. ∞

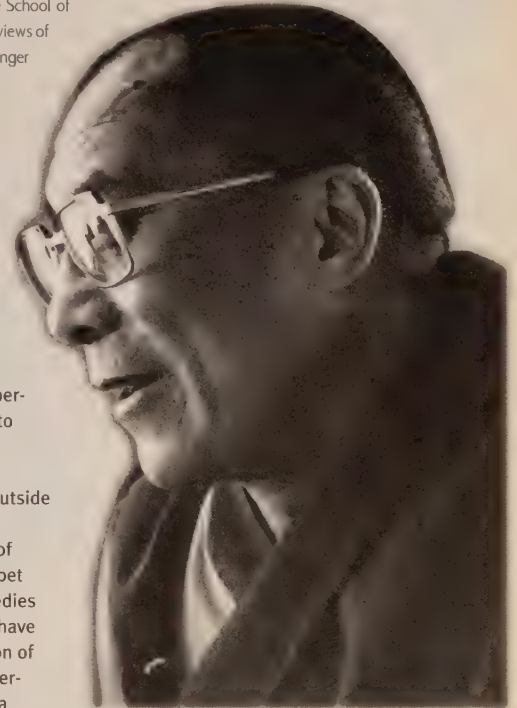
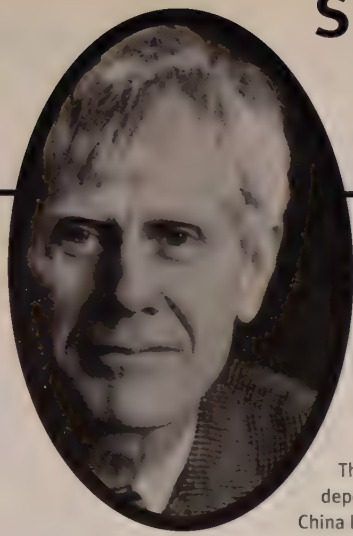

FROM *ANNOUNCES OF THE WORLD*



INTERNATIONAL LAMPALHA FOR TIBET

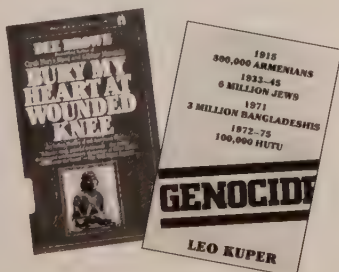
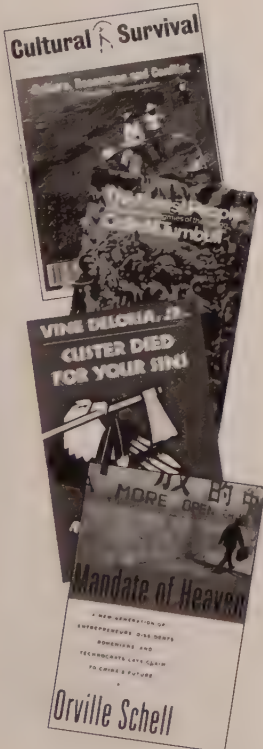

Cultural Survival Quarterly. \$45 membership includes quarterly magazine. 96 Mt. Auburn Street, Cambridge, MA 02138, 617/441-5400, www.cs.org. *The Forest People*. Colin Turnbull. 1961; 295 pp. \$12. Simon & Schuster. *Custer Died For Your Sins: An Indian Manifesto*. Vine Deloria, Jr. 1970; 278 pp. \$14.95. University of Oklahoma Press. *Mandate of Heaven: A New Generation of Entrepreneurs, Dissidents, Bohemians, and Technocrats Lays Claim to China's Future*. Orville Schell. 1995; 464 pp. \$14.50. Simon & Schuster. *Bury My Heart at Wounded Knee: An Indian History of the American West*. Dee Brown. 1970; 458 pp. 14.95. Henry Holt. *Genocide*. Leo Kuper. 1988; 256 pp. \$17. Yale University Press.

DESIGNING/RESTORING

VITAL CITIES

by JANE JACOBS

Jane Jacobs's *The Death and Life of Great American Cities* changed urban planning and policy by simply asking: what makes a vital city? She's followed through in her home, Toronto, leading a successful plan to stop both a major expressway and the demolition of an entire downtown neighborhood. *Cities and the Wealth of Nations* (1984) connected city vitality to global economics. *Systems of Survival* (Whole Earth No. 94) displayed the minds of guardians vs. traders in the economies of the world. She is now, at 82, finishing her book on *The Nature of Economy*. She was willing to be included in this issue of *Whole Earth* only if Stewart interviewed her (she loves his *How Buildings Learn*).

JJ: Cities are the chief motors of economies. You can't talk about economies without talking, at least obliquely, about cities. Any human settlement is an economic equivalent to a local ecosystem. Just as ecology is the economy of nature. I've just been looking at the same thing from the opposite point of view—the nature of economies.

SB: Presumably that steps you right up to the question of global economy.

JJ: Yes. The nature of economies comes to that. But people want these prescriptions. You can't prescribe for a global economy any more than you can get a handle on prescribing for a global ecosystem. Also, if you get too abstract about these things they become meaningless. You can't put everything in one ball of wax without it becoming abstract.

SB: Is the Internet something that is interesting to you in relation to all this?

JJ: It interests me as one more remarkable self-organized system, but there are lots of other self-organized systems. When the civil mail system began, it was self-organized and was only later taken up by institutions and systematized. It got quite organized by people who would go to taverns where they knew that travelers were and earn a little money by picking up letters to deliver, especially around waterfronts or coaching stations. Then people began organizing themselves as post offices and postal carriers. One big difference was that the person who received the letter paid, which was a guarantee that it would be delivered.

SB: The history of the Internet repeated some of that because it was first created as a way to share computer resources between big computation centers. It never worked for that. It was immediately put to use for email. That's when the whole thing took off.

JJ: So this is not unprecedented at all in principle. I used the mail system because it's such an analog, but in fact almost everything when it starts is self-organized. Of course when mail systems were institutionalized they made some improvements like imposing honesty on the carriers, which made it possible to pay for the letter before it was delivered.

SB: I'm involved in a project trying to build a 10,000 year clock and a 10,000 year library and some artifacts that help people think long term. We got to looking at institutions that have existed for a long time, like more than a thousand years. National governments don't qualify, by and large. Corporations don't qualify. Those that come up are pretty much religions and a few universities and cities.

JJ: Cities are about the most durable things we have. People think of them as superficial things, but they aren't. They're very, very basic. Rural places, which are considered more fundamental and more basic, actually are hangers-on of cities in most cases. I explained that in *Cities and the Wealth of Nations* and in *The Economy of Cities*. Cities with economies have very long lives. They aren't just artificial cities that live on taxes, or capitals. Capitals don't last long.

SB: Cities that were on a coast where the coast has disappeared, because the land lifted or got silted in, die pretty quickly.

JJ: Yes, because trade depended on those things.

SB: Are there any cities that polluted themselves to death?

JJ: I've read about ones in Mexico that are supposed to have denuded the land. And some cities in India seem to have ruined themselves by deforestation and then mud slides and so on. But you have to realize that cities are often very capable of correcting their mistakes; when you find one that just goes on doing the wrong things and gets killed by it, it also means that for some reason they've become incapable of developing.

Look at the European cities that managed to overcome epidemics. And they didn't do it with one quick fix. It took a lot of different things, a lot of different measures, including control of sewage.

SB: London used to burn every few years and then they caught on and stopped building out of wood and built out of masonry.

JJ: Absolutely. Again, it wasn't just one thing. It wasn't just the change to brick and stone. It was also fire-fighting systems, which at first were self-organized. The Dutch became wonderful at having fire-fighting hoses and water, because they already were so good at pumping, due to their lowlands. That spread to other places, which made it possible for water to reach up into quite high buildings. In Amsterdam today you can look at those narrow, tall buildings, the old ones.

SB: That's the famous way to maximize real estate value.

JJ: It wasn't just real estate value. It was all the values of a city. A lot of them have to do with saving energy and saving resources—all the things that we criticize sprawl for now, the opposite of that. When I hear people talking about maximizing real estate values, I think they're really thinking of superficiality. They aren't thinking of what's underneath that, the saving of resources.

I also think that people don't necessarily need the most dire things to inspire

change. Fashion is quite important; it keeps us from doing the same thing all the time. Think how people got tired of Victorian fashions and all of a sudden they couldn't stand them anymore. They were ruthless about wiping them away.

This is about to happen, I think, with our present sprawl and suburbs. They're going out of fashion. I think all kinds of things will happen to them. Again, it isn't one fix or one change. I imagine that they will be thickened up to quite an extent. They'll be denser. Already, shopping centers are getting to be abandoned where there have been too many of them. The first thing to think of would be to bulldoze them and put something else there. But that's not obviously the best choice anymore. You think, what can you put in there that's different? Can you change some of it to housing? Can you have some stores in it? I think that the suburbs will change quite a bit from new, and imaginative, uses of that kind.

SB: What would it take for cities to themselves become a thing of the past? People would say, "Oh yeah, remember when we used to have cities?"

JJ: I think we would have the Dark Ages again. That's what happened the last time.

SB: I looked into that. Europe was de-urbanized by the fall of Rome.

JJ: Sure. That was the big thing that happened. That's one reason I say that rural areas depend on their cities. They get wiped out if the cities do.

SB: But what was the mechanism there? Why would the fall of Rome mean the cities would empty? I don't follow the sequence of events.

JJ: Stewart, you want me to write a whole book that I've already written a couple of times. ∞

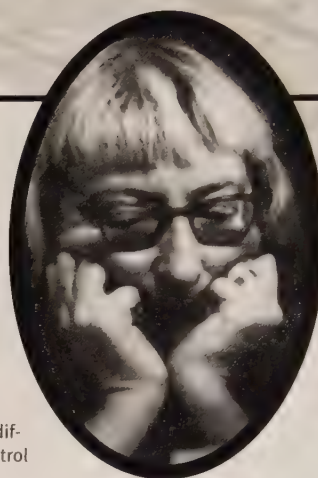

HUGH FERRIS, FROM THE COLLECTION OF ANN FERRIS HARRIS, MYSTIC, CT



DESIGNING 29

Ideas That Matter: The Worlds of Jane Jacobs. Max Allen, ed. 1997; 213 pp. \$24.95. Ginger Press, 848 Second Avenue East, Owen Sound, Ontario N4K 2H3, 519/376-4233, log.on.ca/gingerpress. **Systems of Survival: A Dialogue on the Moral Foundations of Commerce and Politics.** Jane Jacobs. Reissue edition, 1994; 236 pp. \$13. Vintage Books. **The Death and Life of Great American Cities.** Jane Jacobs. Reissue edition, 1993; pp. \$18.50. Modern Library.

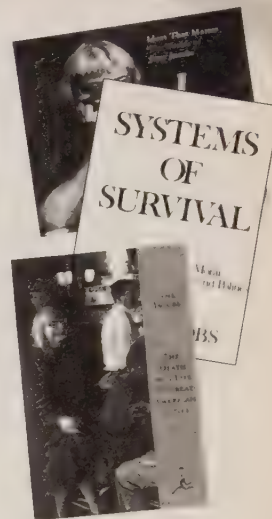

The Earth Manual. Malcolm Margolin. revised edition, 1985; 237 pp. \$16. Heyday Books, PO Box 9245, Berkeley, CA 94709, 510/549-3564. **Technics and Civilization.** Lewis Mumford. 1990; 495 pp. \$22. Harcourt Brace. **Ecology of Greenways: Design and Function of Linear Conservation Areas.** Daniel S. Smith and Paul Cawood Hellmund, eds. 1995; 222 pp. \$39.95. University of Minnesota Press. **Asphalt Nation: How the Automobile Took over America and How We Can Take It Back.** Jane Holtz Kay. 1998; 418 pp. \$16.95. University of California Press.

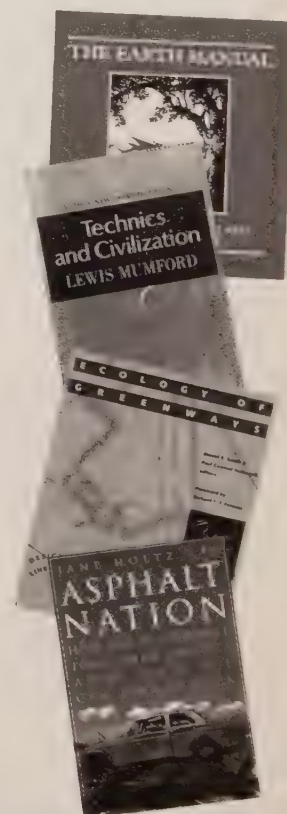



REDESIGNING DESIGN ITSELF

by WILLIAM McDONOUGH

William McDonough is the prime ambassador between three decades of grassroots experimentation with sustainable building design and the mainstream world of architects. Diplomatically pushing architecture from ego to ecology, extravagance to smart materials, he designed the Environmental Defense Fund Headquarters, the Warsaw Tower Project, and has helped Wal-Mart inch along toward more ecological intelligence. He's Dean of the School of Architecture at the University of Virginia, wrote the Hannover Principles for the 2000 Expo, and won the US Presidential Award for Sustainable Development.



THE GODS CHILD AGAIN FROM THE HUT IN A.E. 1983. NANCY WOLF. COURTESY OF MARSHA MATENGA GALLERY, WASHINGTON, DC

Symmetry. Istvan Hargittai and Magdolna Hargittai. 1996; 222 pp. \$18. Shelter Publications. **A Pattern Language.** Christopher Alexander, Sara Ishikawa, and Murray Silverstein. 1977; 1171 pp. \$55. Oxford University Press. **The Hannover Principles: Design for Sustainability.** William McDonough. For information, contact William McDonough Braungart Design Chemistry, 804/295-1111, hp@mbdc.1111. **An Artist's Sketchbook of Underground Buildings: Drawings and Photographs.** Malcolm Wells. 1990; 196 pp. \$14.95 (post-paid). Malcolm Wells, 673 Sawtucket Road, Brewster, MA 02631, 508/896-6850.

Close to my heart and mind right now is a new design protocol focused on this fundamental question: "How do we love all the children, not just our children, but all the children, of all species, for all time?" This points to considering design at a Jeffersonian scale, as a way seeking life, liberty, and the pursuit of happiness free from "intergenerational remote tyranny"—the tyrannizing of future generations by our actions today.

Consider leaving a legacy like this:

- billions of pounds of potentially toxic waste in the air, water, and soil;
- thousands of complex regulations to keep people and natural systems from being poisoned too quickly;
- "prosperity" measured by how many natural resources are dug up and cut down, then buried, burned or otherwise degraded;
- valuable materials piled in landfills all over the planet, where they can never be retrieved;
- materials so dangerous they will require constant vigilance by future generations;
- collapsing cultural and biological diversity.

What we want instead of this hyperactivity is to imagine and then engage a notion of legacy, a legacy of abundance and hope that respects the right of all living things to exist within a healthy and prospering world. This means we have to imagine what this world might be like and begin designing for it right now.

Working with Dr. Michael Braungart and many other professional colleagues, I have been articulating the redesign of design itself, responding to new information about bioaccumulation, endocrine disruptors, climate change, the loss of biological and cultural diversity, and other signals of design failure, more of which are emerging every day. These

are serious signals, and they deserve more than quick fixes or filters on the ends of pipes. Change will not be effected by doing the things we're presently doing more efficiently.

In this context, even the much-lauded

eco-efficiency practices have a dark side; they don't change the story, they just slow it down. They may even have a pernicious effect by lulling people into believing that something "good for the environment" is being done. Instead, Dr. Braungart and I have developed a new paradigm, which we call "eco-effectiveness." In contrast to eco-efficiency, which asks us to be less wasteful, our concept of eco-effectiveness asks that we eliminate the entire concept of waste. Eco-effectiveness celebrates industries that are closed loops (like nature's near-perfect recycling systems), that respect biological and cultural diversity, and that are driven by current income from the sun.

Eco-effectiveness involves designing products and materials that can be safely returned to biological or industrial systems, so that "waste equals food." These products will be literally "cradle to cradle" instead of cradle to grave. Safe shoes can become safe shoes or another safe product forever. Televisions can become televisions or other electronic service devices forever. Other things, like beverage containers and food packaging, for example, can be used as safe compost to restore vitality to the soil, or used as safe fuel where needed. This is design that replenishes rather than depletes, that leaves our children with a richer and more fecund world instead of an impoverished one.

Eco-effectiveness demands very specific design protocols. Recycling things a few times before they go into a landfill, or recycling materials with dangerous substances in them forever, is not what we're talking about. Nor is "dematerialization"—simply making products or packages smaller. If a source-reduced product still contains potentially harmful substances, we are not yet loving the children. Dr. Braungart and I have coined a new concept: rematerialization. Harmful substances will not be a part of a product's materials. They will be designed for constant human and natural purposes—true recycling, not just "downcycling," a term we use to describe the process of reducing a material's quality over time until it is no longer valuable.

The design assignment for the future? Imagine a city that tries to love all the children. What are its roads like? Are they paved with petro-

chemicals? Do its factories pour toxic chemicals in the air, water or soil? Is transportation causing global warming? Are single-purpose buildings ending up as heaps of useless materials in a construction landfill? Is human sprawl destroying biological and cultural diversity? Is the air safe to breathe? Children take in fifty percent more air into their lungs when they breathe, so this is a serious consideration. They are not small adults.

Why not have a city—a world—full of these things instead:

- buildings and factories like trees that purify their own wastewater, accrue solar income, and produce oxygen and food;
- products that do not become useless waste, but remain high quality materials for industrial cycles forever;
- industries that use "intelligence filters" instead of filters on the ends of pipes;
- industries that use positively defined materials, instead of less "bad" materials.
- development that respects and celebrates biological and cultural diversity.

Generations from now, will the children look back at our actions and say, "What have they done?" Or will they celebrate our creativity and be filled with hope? Sustainability is global when design becomes ecologically, economically, and socially replenishing. And we'd better start right now because a sustaining agenda will take forever: that's the point. ∞

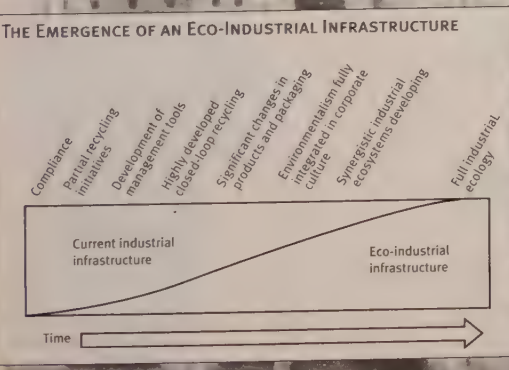
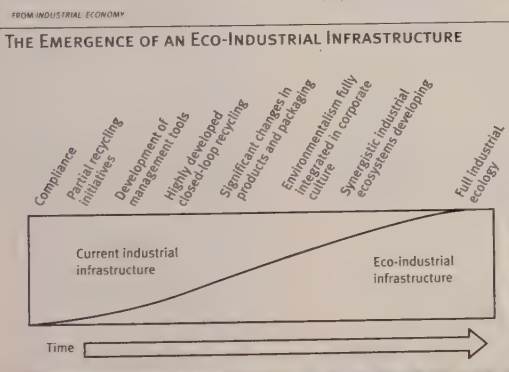

ENERGY LESSONS LEARNED AND TO BE LEARNED: VERITIES THAT WILL ASTONISH SOME AND DELIGHT THE REST

by AMORY B. LOVINS

Amory Lovins, co-founder of Rocky Mountain Institute, (www.rmi.org) is, of course, Benjamin Franklin's dream of Mr. Waste-Not-Want-Not. Say the "E" word and Amory's insights, encyclopedic recall, great light shows, tightly written arguments, and persuasive lectures to grassroots advocates or CEOs or security mavens pop to mind. Energy and integrated design will be featured in his and Hunter Lovin's new book with Paul Hawken, *Natural Capitalism*.

DESIGNING 31



1. **Total US energy use is now slightly below the level suggested in my 1976 "soft energy path" graph (see figure), widely criticized at the time as wildly optimistic.** Renewable energy growth was delayed a decade by federal hostility, but is starting to gain momentum. A "third wave" of energy efficiency may be starting, reversing the 1986-96 period of stagnation. If we learn its lessons, this success can be greatly expanded, and extended to other resources.

2. **Environmental problems from using energy are unnecessary.** It's cheaper not to have them. Meeting and surpassing the Kyoto targets will be not costly but profitable—saving fuel costs less than buying fuel. Climate politics will therefore shift from price, pain, penalty, bearing burdens, and sharing sacrifices toward profit, enterprise, initiative, innovation, and competitive advantage. This shift will make consensus straightforward; no matter how the climate science turns out or who goes first, protecting climate boosts practitioners' bottom lines.

3. **New design techniques can often make big energy savings cost less to achieve than small savings.** "Tunneling through the cost barrier" has been empirically and convincingly demonstrated in many technical systems, but such new design is absent from all energy models because they're based not on engineering practice but on economic theory.

4. **Energy efficiency and distributed power generation will increasingly be bought for reasons other than saving energy commodity costs.** Energy efficiency and power generation will be bought, respectively, for qualitatively superior services and distributed benefits.

5. **Ability to respond to price is more important than price itself.** Price matters, but its policy importance has been much overrated. High energy prices are neither necessary nor sufficient for very efficient energy use.

6. **Restructuring the electricity industry will yield surprisingly small benefits unless retail distributors are rewarded for cutting customers' bills rather than for selling more energy.** Restructuring matters, but mainly benefits big users ("big dogs eat first") and confuses small ones. Regardless of restructuring, utilities can't compete without helping customers wring more work from each kilowatt-hour. That's the only important way to yield better service and lower bills.

7. **Big, fast energy savings can yield after-tax returns over 100 percent per year even at or below today's low US energy prices.** After saving \$150-200 billion worth of US energy use per year in the past twenty-five years, we're still wasting upwards of \$300 billion a year. End-use efficiency is a rapidly expanding resource, because learning outpaces doing. Its returns to scale don't diminish but rather expand.

8. For many smart companies, capturing these savings is gaining momentum for competitive reasons, but is inhibited by sixty to eighty specific kinds of market failures, some at the level of the firm and some in public policy. **Proven techniques can turn each of these market failures into a lucrative business opportunity.**

9. American firms that are starting to discover this are increasingly behaving as if the Kyoto Protocol had already been ratified by the US Senate. The more firms so behave, the more likely and less necessary ratification becomes. **US leadership on climate protection has largely passed from the public to the private sector,** simply because efficiency costs less than fuel. By 2000, carbon-reduction market-makers will have discredited climate skeptics' theoretical economic models by discovering empirical prices 10-100 times below their predictions.

10. **Specific efforts to cure market failures in buying energy efficiency should top the public-policy climate agenda.** Most countries ignore them, wrongly assuming they need only proper pricing and fuller commodity competition. Countries making this error will fall further behind those that take market economics seriously rather than literally.

11. R&D will yield important advances. But optimal application of old, even Victorian, technologies would probably suffice to meet the Kyoto goals at a profit. **Technological R&D must be supplemented by improved design education, retreading of in-practice design professionals, and greater attention to energy anthropology (the emerging science of why people use energy the way they do).**

12. A market-driven transformation already irreversibly underway will rapidly bring **new light vehicles,** including full-sized American ones,

above eighty and often to 100-200 mpg. Early models, including fuel-cell cars, will start to enter the market around 2000, with major market shares shifted by 2005-10. Automakers that fail to make the transition to ultralight, ultra-low-drag, hybrid-electric vehicles will risk disappearing. Over the next few decades, such Hypercars™ and their kin will save an OPEC's worth of oil. Complementary policies to maximize competition between ways to get around and not needing to get around—for example, eliminating sprawl by not mandating and subsidizing it—can also yield better and fairer access with much less driving.

13. Twelve powerful forces are driving a rapid transition to distributed electric generation, where the power plant shifts from remote, gigantic stations to your roof, basement, backyard, and driveway. **The central power plant is already obsolete** and, like much bulk electric transmission, will become uneconomic to run and difficult to sell. Such plants are unlikely to survive in any significant numbers by 2030. Unpleasant vulnerabilities built into the architecture of brittle, highly centralized systems (e.g. Y2K problems) could greatly accelerate this trend.

14. Many of the **distributed resources will be renewable** as their costs inexorably drop and their quality and convenience improve. Even if the renewable transition took a couple of centuries, it could be bridged by abundant and nearly ubiquitous natural gas. Its use won't harm the climate if its CO₂ is separated out at the wellhead and reinjected into the reservoir. This is generally profitable because it yields three income streams: sale of H₂ as a premium fuel, enhanced recovery of CH₄, and trading sequestered carbon under Kyoto Protocol rules.

15. **A smooth transitional path to a climatically benign hydrogen economy has already been devised,** appears profitable starting now, doesn't need major infrastructure investments, and is already being adopted by large and capable energy and automotive firms.

Much of the energy-carrier role projected for electricity will use hydrogen and fuel cells.

16. So diverse and robust are the existing and emerging competitors that oil will probably become uncompetitive even at low prices before it becomes unavailable even at high prices. **The most intelligent oil majors already understand they're in the coal-and-oil endgame;** the only internal dilemma is whether to say so.

17. The possibility of **wholly new energy sources** consistent with the laws of physics—but going beyond the special-case physics we ordinarily observe—cannot be excluded. However, such sources are unlikely to be free, and may prove uncompetitive with existing sources, let alone with efficient use.

18. These developments in the North fit beautifully with leapfrog development strategies for the East and South, and could free capital for other development needs. **The spiritually underdeveloped North will discover the futility and vanity of trying to meet nonmaterial needs by material means.** Energy and resource efficiency don't correct excessive population or consumption—they just buy time and earn money needed to address such fundamental problems.

19. **The most fundamental and important innovations will come from biological design models** in every aspect of our lives, notably redesigning production and commerce, reshaping control, and taking our goals and worldviews not from Bacon and Descartes but from Darwin and Thoreau, Leopold and Lewis Thomas, Kevin Kelly and Janine Benyus. Energy is but one of a myriad of fields that the biological paradigm will transform.

20. **In short, past energy surprises pale in comparison with those now certain to occur.** However, this neo-cornucopian vision, though basically market-driven, has vital roles also for public policy too, albeit with non-traditional emphases: the cornucopia is the manual model, and one must actually turn the crank! ∞

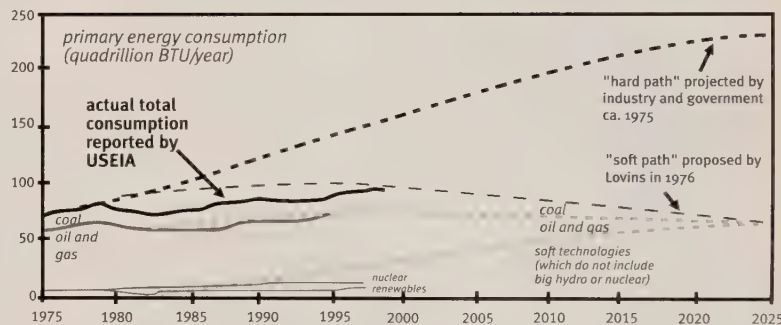
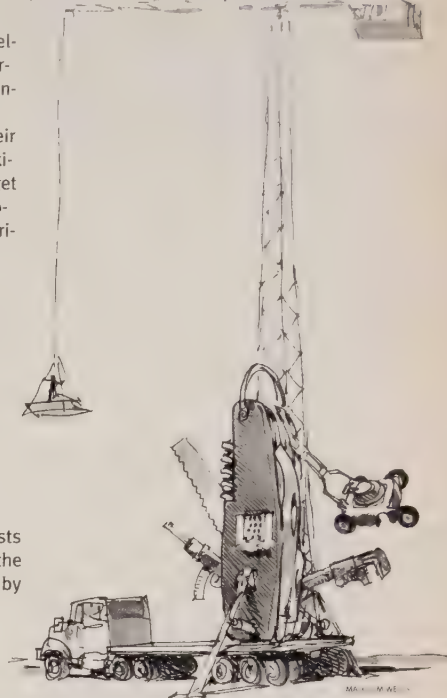

Home Power: The Hands-On Journal of Home-Made Power. \$22.50/yr (six issues). PO Box 520, Ashland, OR 97520. 530/475-0830. www.homepower.com. **Designing Interactive Strategy: From Value Chain to Value Constellation.** Richard Normann and Rafael Ramirez. 1994; 155 pp. \$88.50. John Wiley & Sons. **Industrial Ecology: An Environmental Agenda for Industry.** Hardin C. Tibbs. 1992; may be downloaded at www.sustainable.doe.gov/articles/indec01.htm.





THE GARDEN PROJECT

by CATHRINE SNEED

Cathrine Sneed works on the frontlines of poverty, drugs, prisons, and family/personal renewals. Her tools are remarkable horticultural, legal, and counseling skills as well as perseverance and insight. Overwhelmed by good works, Cathrine offered us her talk from the 1998 Bioneers conference (www.bioneers.com). This is about half of it. The full tape is available for \$10 (\$12 postpaid) from Conference Recording Service, 1308 Gilman Street, Berkeley, CA 94706, 510/527-3600, www.conferencerecording.com. The Garden Project always needs more outside support. The Garden Project, Pier 28, San Francisco, CA 94105, 415/243-8558, www.gardenproject.org.

While I say I started The Garden Project, I feel like that's not complete. I started it with the help of a lot of people—the prisoners as well as people who have wanted to help. What really is for me the most important part of our project is that we have people who are in need of restoration and they are the ones working very hard to restore themselves and also to restore their neighborhoods, to restore their communities, to restore their families. That's very important to me.

The project has three parts. The first is the program in the jail. Since I started it in 1982 more than 10,000 prisoners have been in the program. Most of the people in our jails and prisons throughout the country are there because they're poor. They're there because they've sold and used drugs. Unfortunately, they're there because they're people of color.

We've grown a lot of food that we've given to soup kitchens and senior centers and community centers. But growing food and giving it to these places is what's helped to restore the prisoners and the participants in the program, because they're able to give something. They're able to give of themselves. Over the years people have asked me, "Why don't we sell the food instead of giving it to the community centers?" You have to give to live. In giving the food they've worked very hard to grow, people begin to care about themselves. They begin to care about other people.

In growing food for the soup kitchens and for the jail, they begin to learn about their bodies. They begin to learn about health. Over the years I've always asked people, when you got arrested what were you eating? Generally they say the same thing. I don't know if you've noticed, but when the poor get money they go to McDonald's. They take their kids there. It's a source of pride. What I'm seeing is more and more people who aren't eating or cooking food at home. Having talked to thousands of prisoners over the years, I have concluded that their diet is why they're using drugs. This is why they're craving crack. They were not eating vegetables. Many of them have never eaten vegetables that didn't come out of a can or weren't frozen. In San Francisco, the only store in the neighborhood where most of the people in our jail live doesn't have fresh vegetables; most of the stuff is pre-packaged. That's what this community of over 58,000 people has available to it.

We're really trying to change that. With the Garden Project, which is the second part of our program, we grow food and try to get it to the community that needs it, where it's grown. Our garden is about half an acre. It's here in Bayview-Hunters Point, a community mostly of African-Americans. There are at least two Superfund sites in Bayview-Hunters Point. When most people there go to shop, they go to the corner store. It's a liquor store. So I think it's the role of our project to offer food to this community, which desperately needs it. We invite people to come to the garden. We invite seniors to come. When the seniors come to pick vegetables, they see the same people who might have been on the corner trying to take their purses, or knock them out and rob them. They see that the same people are now giving back and trying to help. That changes something for them. The prisoners begin to see and feel badly about what they have done to support their habit. The garden does that, growing this food does that.

The garden also offers a place for parents. Most people who are in jail or prison are parents. Instead of leaving their children in the housing projects to come to work, or deciding that they can't come to work because they don't have child care, they bring their children to the garden. The kids run through the garden and pull up everything and, I tell you, this makes it a little difficult, but it's well worth it.

There's a kid that I'm particularly fond of. His name is Paradise. Paradise is Samoan. I will never forget a couple of years ago when his father was supposed to meet me to work really early in the morning at the garden. I was there, sitting in the van, and I heard Paradise crying in his father's car. I immediately thought his father must be hitting him or something, because unfortunately that had happened before. I got out of the van and asked Paradise what was going on. He was crying and crying and crying. His father just threw up his hands and said, "I don't know what's

wrong with him." I said, "What's wrong, Paradise, what's wrong?" He said, "I don't want to eat what my father brought." I asked, "What did he bring?" He said, "He brought me donuts. I don't want donuts. My teacher said that's not nutritious. I don't want to eat that." This kid was maybe six years old then. I said, "Well, Paradise, I brought some strawberries and some peaches and some bagels and so let's have them." He grabbed the bag. He was just so happy to have something other than donuts to eat. His father had been a drug user for many years; he's a single parent and over the years it's been a struggle to save Paradise. "Take these greens home and cook them. Feed the kids salad. It's food." That's not his orientation. We're trying to teach people about nutrition, to teach people about health, and not just by lecturing to them, but by showing them. So we grow, make, and eat food in the garden. The prisoners and the former prisoners are learning to eat vegetables and this really offers them a way to feed their families.

The third part of our program is the Tree Corps, which was started as a way to deal with the fact that in Bayview-Hunters Point, and in other places in San Francisco, we have streets with no trees. None. When we plant the trees it makes a difference because the neighbors, the people that live in the community, see people who need jobs. So, the vandalism rate for our trees is actually much lower than for the trees that the City plants. When the trees survive, that tells me that what we're doing works. Also it works because it puts people to work. It's letting Paradise's father and other people bring a check home every week instead of relying on welfare or drug sales to survive.

More than all three of these things, what I'm trying to do is help people to see what's happening in our jails and in our prisons. I'm not alone in this. A lot of people have done this all over the country. As citizens we are allowing our government to spend an amazing amount of money to keep people, mostly people of color, in jail for the crime of being poor. There has to be a time where we say as a community that in order to heal our community we need to involve the people who have hurt the community.

The other day a man that I've known from the jail for the last fifteen or so years came to our office. I hadn't seen him in ten years. I started telling him how the program had changed from the time when we worked in the jail. "So what's up with you? How's your family?" "Well, I don't see my family anymore," he said. "My son died in San Quentin in a gang fight." I remembered his son. I said, "But I haven't seen you in ten years. Where have you been?" He said, "Oh, I've been in and out. I've been to State Prison, back and forth. I'm still not off parole." So, in ten years this man has been on the street probably a total of three months and then he's back. James' crime is being addicted to crack. That's his crime. I'm not a mathematician, but it seems like a lot of money to send James back and forth to State Prison for ten years. We're talking \$25,000 or more each year, when you calculate what being in jail does to the family that's involved. There's no one bringing any money home. Most of the children I know whose parents have been to jail end up in jail themselves. The cycle just continues.

This cycle is spinning out of control and bringing more and more communities into it while we pay for it. At some point we have to say this doesn't make sense, and stop it. At some point we have to look at the fact that there are children who aren't eating in America. They're not eating food. They're eating garbage. These same children are going to grow up, and when they grow up I'll bet you many of them will follow the path of their parents. They'll be addicted to drugs.

In California we spend more on prisons than we do on our schools. That is criminal. We're wasting our money, we're wasting our energy, and we're misdirected when we think that the problem of crime is the problem of people of color going awry. That's not what's happening. What's happening is that the young men and young women in our jails and prisons are there mostly because they're addicts and because they're poor. And if we can't do anything about that, then we won't restore the earth. We need to restore the people first. ∞

People, Land, and Community: Collected E.F. Schumacher Society Lectures. Hilgard Hannum, ed. 1997; 352 pp. \$18. Yale University Press. Including pieces by Cathrine Sneed, John Todd and Nancy Jack Todd. **The Once and Future Forest: A Guide to Forest Restoration Strategies.** Leslie Jones Sauer. 1998; 381 pp. \$30. Island Press. **Small is Beautiful: Economics As If People Mattered.** E.F. Schumacher. Second edition, 1998; 320 pp. \$19.95. Hartley and Marks. **The Growing Edge: News and Information for Indoor and Outdoor Growers.** \$26.95/year (six issues). Tom Alexander, publisher. 341 SW 2nd Street, Corvallis, OR 97333. 541/757-8477. www.growingedge.com. **Gaviotas: A Village to Reinvent the World.** Alan Weisman. 1998; 231 pp. \$22.95. Chelsea Green, PO Box 428, White River Junction, VT 05001, 802/295-6300. **Ancient Futures: Learning from Ladakh.** Helena Norberg-Hodge. 1991; 204 pp. \$12. Sierra Club Books.



Announcing the Margaret Mead 2001 Awards recognizing community creativity for a new century

from the Margaret Mead Centennial Committee, Institute of Intercultural Studies, and Whole Earth

"Never doubt that a small group of thoughtful, committed citizens can change the world. Indeed, it's the only thing that ever has."

When Margaret Mead died in 1978, she was the most famous anthropologist in the world. In her honor, starting in 1999 and continuing through 2001, the centennial year of Margaret Mead's birth, Whole Earth and Margaret Mead's foundation, the Institute of Intercultural Studies, will join together to honor small groups of thoughtful, committed citizens who have changed the world.

Mead always believed in the human capacity to change, insisting that the cultural habits of racism, warfare, and environmental exploitation are learned. She promoted human diversity as a teaching tool; pointed to modified traditions and new institutions that had successfully adapted to a changing world; and praised groups who were inspirations, models and vehicles for learning from one another. Her goal was nothing less than intercultural and international understanding as a foundation for human freedoms.

If you know of a small group (fewer than 100 people) anywhere on the planet that has worked to change the world; that has cross-connected issues such as race, environment, intergenerational learning, child rearing, and gender understanding; that has developed an organization or series of tools that others can learn from; and that takes a long view of cultural understanding, please send your nominations to:

Mead 2001 Awards
PO Box 3223
Petersborough, NH 03458
or nominate@mead2001.org



In 1925, Margaret Mead lived in American Samoa studying adolescent girls. *Coming of Age in Samoa* became a world best seller presenting, for the first time, the idea that stormy adolescence might not need to be so stormy, depending on culture. In 1929, among the Manus of New Guinea, she pushed her paradigm. In *Growing Up in New Guinea*, she told "civilized" humans that they had a lot learn from the "primitives" about passages from childhood to adulthood to old age. She then extended her fieldwork to gender roles and, with Gregory Bateson, used photographs to document the subtleties of child-rearing and adult culture. In 1953, after World War II, she returned to Manus and documented in *New Lives for Old* the historic cultural change caused by the globalization of formerly local, isolated peoples. Her academic home was the American Museum of Natural History. Her awards, including the Presidential Medal of Freedom, are obviously numerous.

LIVING TECHNOLOGIES FOR A LIVING PLANET

by JOHN AND NANCY JACK TODD

From the headwaters of creativity, the Todds floated to the innovative mainstream. They're great tinkerers and inventors of biological sewage treatment plants (with real plants and fish and snails and...) and other components of ecological sustainability, including an effective demonstration project to clean up toxics in Chattanooga (see *Chattanooga Sludge*). They work from Ocean Arks International and publish (with Lindisfarne) a thoughts-full newspaper called *Annals of Earth*.

an unprecedented partnership with the natural world, ecological design at Ocean Arks has generated a new and hybrid form of technology. This technology, literally drawing on the intelligence encoded in the processes of evolution, incorporates elements from the living world in the form of thousands of selected organisms. Harnessing "larger mind" in this way is a new step in the coevolution of human and natural systems. This partnership of human ingenuity and resilient biological self-maintenance has the potential to replace the present technological infrastructure with more sustainable living technologies.

Living technologies incorporate the use of Living Machines, which were invented and developed at Ocean Arks. A Living Machine is made up of a contained ecosystem that has been inoculated with thousands of life forms including microorganisms, snails, fish, and higher plants. Confidence in their ability to self-design, self-organize, self-repair, and maintain their ecosystems is at the core of the design philosophy. Such a machine is intended to solve problems and perform designated tasks that can range from the restoration of water, waste treatment, growing food, air purification, climate moderation, treating industrial wastes, and environmental remediation. The progress of the ongoing research is documented in the Ocean Arks publication *Annals of the Earth*.

Less expensive and more effective than their industrial counterparts, living technologies have the potential not only to solve problems of

production and pollution; they are also instruments of environmental restoration. Widespread application of living technologies could prove an unparalleled and dramatic means of shrinking the human footprint on the planet. To date, Living Machines have been installed in fifteen states and nine countries, including India and Brazil. Ecological design is also being incorporated into educational programs and taught in schools and colleges. The children and young people involved are learning to interact with the living world, to think like an ecosystem. They are coming to understand their world not merely as a resource base but as living planet to be cherished. ∞



One of John Todd's Living Machines

New Pioneers: The Back-to-the-Land Movement and the Search for a Sustainable Future. Jeffrey Jacob, 1997: 257 pp. \$26.50. Penn State Press. **Chattanooga Sludge.** Molly Bang, 1996: 48 pp. \$16. Harcourt Brace. **Annals of Earth.** Nancy Jack Todd, ed. Included with \$30 annual membership in Ocean Arks International, 233 Hatchville Road, East Falmouth, MA 02536, 508/563-2880, www.vsp.cape.com/~bjosephs.

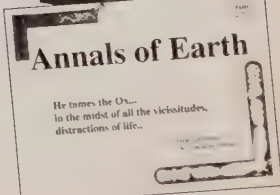

Humanity's present overarching crisis has been summarized by author and environmental educator David Orr as follows: "The problem is simply how a species pleased to call itself *Homo sapiens* fits on a planet with a biosphere." "This is a design problem," he maintains, "and requires a design philosophy that takes time, velocity, scale, evolution, and ecology seriously."

The design philosophy that David Orr advocates is emerging from our research of the last thirty years. It is now being codified into a scientific discipline and successfully implemented in a number of areas critical to both *Homo sapiens* and our biosphere-blessed planet. Gregory Bateson, who pioneered such thinking, wrote of the mind as "immanent, but not only in the body" and of a "larger mind of which the individual mind is only a subsystem ... still immanent in the total interconnected social systems and planetary ecology." That larger mind is observable not only in the metabolism of the living world. It is conspicuously reflected in the self-organizing processes of the contained ecosystems which were first developed by the aquaculture research at the New Alchemy Institute in the 1970s. The technique and technologies have since been honed at Ocean Arks International to form a body of knowledge, now referred to as ecological design.

Ecological design is a comparatively new discipline. It involves more than using renewable resources like solar and wind energy in lieu of fossil fuels or nuclear power. Predicated upon

BEAUTY



CARNIVAL

by BRIAN ENO

A Model for Culture

Brian Eno is known as a record producer (U2, David Bowie, Talking Heads, Laurie Anderson). This is too small a box for a musician, composer, artist, and writer. I've rarely met a more erudite, surprising, and matrixed mind. His book *A Year with Swollen Appendices* is a crystal teacher of the daily practice of keeping "naturalist" observations. He's a patron of the Institute of Social Inventions, which offers attitude jogging for longevity (see more in our Spring 1999 issue).

What makes for a great carnival? I've pondered this question, as I've watched, year by year, the Notting Hill Carnival in London expanding to become the world's second largest (after Rio's).

My conclusions: Carnival is good when the number of participants isn't grossly outweighed by the number of spectators. Carnival is good when many of the 'spectators' are actually also joining in (dancing and singing along). Carnival is good when the participants exhibit a range of skills from the absolutely minimal to the absolutely astonishing (the first being an invitation not to be intimidated—"Hey! I could do that!"—and the second an invitation to be amazed). Carnival is good when people of all ages, sexes, races, shapes, sizes, beauties, inclinations, and professions

are involved. Carnival is good when there's too much to look at and everything's mixed up and you have to sort it all out for yourself. Carnival is good when it dignifies and rewards all sorts of abilities—singing, jumping, laughing infectiously, dressing weirdly, writing the hit song of the carnival, wiggling your backside, standing on a soapbox praising Jesus or the local hardware store, frying salt fish over an oil drum in public, inventing symphonic arrangements for steel bands, designing and building fabulously impossible things. Carnival is good when people try to outdo each other, and then applaud with delight those who in turn outdo them. Carnival is good when it gives people an alibi to become someone different. Carnival is good when it lets people present the best part of themselves, and be, for a little while, as they'd like to be all the time. Carnival is good



COURTESY OF THE METROPOLITAN MUSEUM OF ART

when it gives people the feeling that they're really lucky to be alive right here and now. Carnival is good when it leaves people with the feeling that life in all its bizarre manifestations is unbeatably lovely and touching and funny and worthwhile.

Now substitute 'culture' for 'carnival.' There's a vision for the future of culture. ∞

DoubleTake. Robert Coles, editor. \$32. Center for Documentary Studies, Duke University, 1317 W. Pettigrew Street, Durham, NC 27705, 800/964-8301. **Looking at Photographs: 100 Pictures from the Collection of the Museum of Modern Art.** John Szarkowski. Out of print.



Impro: Improvisation and the Theatre. Keith Johnstone. 1989; 208 pp. \$16.99. Routledge/Theatre Arts Books.



Drawing on the Right Side of the Brain. Betty Edwards. 1989; 254 pp. \$25.95. J.P. Tarcher. **The Natural Way to Draw: A Working Plan for Art Study.** Kimon Nicolaïdes. 1990; 221 pp. \$14. Houghton Mifflin.

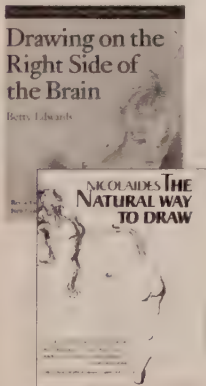

LINEAGES AND LEGACIES

by ANNE WALDMAN

Anne Waldman has been one of my teachers in the realm of Buddhism and a muse and sweet advocate of my writing. She has astounding energy, which she uses to help everyone in the same manner. Her energy bursts/blossoms in poetry like *Fast Speaking Woman* and her performance poetry "readings." Twenty-five years ago, she and Allen Ginsberg cofounded the Jack Kerouac School of Disembodied Poetics, which now sports BA and MFA programs (see access).

Everyone has a story or poem to tell, everyone is interested in reading something besides newspapers or waiting to turn off the set. **Refine the senses through colorful vivid language! Use the imagination! The hell realms of planet earth are versions of ego-maniacal power made hungry ghosts! It's bad poetry! It's land grabs, fossil-fuel driven, genocides of all kinds that need our limber-witted poetic attention and muscle. Jump in, turn it around!** So we've got an activist agenda. And hundreds of graduates from the Jack Kerouac School of Disembodied Poetics (at Naropa Institute) are out there spawning their own projects, schools, publications, bookstores, manifestos, "To Keep The World Sane For Poetry," as our motto goes. In Seattle, in Prague, in New York City.

Temporary Autonomous Zones, Hakim Bey's phrase, are increasingly important. The squeeze is on. How nourishing it is just to get together with a clutch of friends and read and study (the Robert Duncan Group, the James Joyce Group, the Surrealist Cell, Beats & Beyond, Shakespeare for Poets, etc.). Last New Year's Eve friends, family, community, students gathered at my home to welcome in the year with readings of the honeyed, sharp & wise-tongued folk who'd passed on: Allen Ginsberg, William Burroughs, Denise Levertov, Kathy Acker, Elio Schneeman, James Laughlin. **Keeping the flame going with vocalization of their mind breaths and seed syllables is the ongoing ritual.**

The legacies run deep.

Well, while I'm here I'll do the work — and what's the Work? to ease the pain of living. Everything else, drunken dumbshow.

— Allen Ginsberg, from "Memory Gardens" ∞

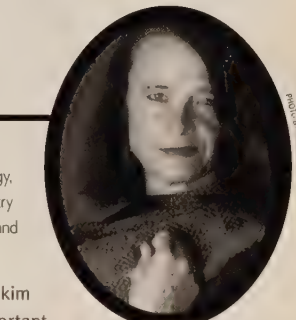

© TONY WALKER/ONYX



© BOB D'AMICO

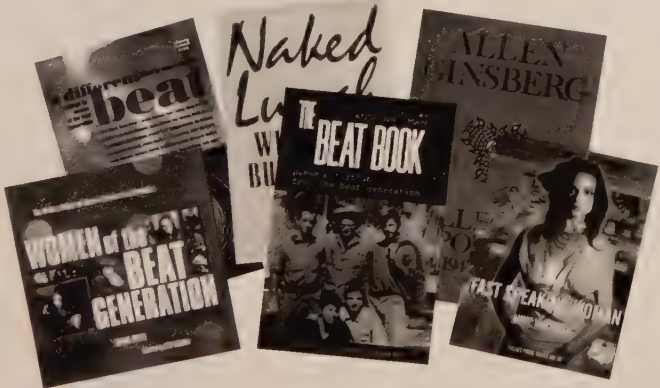

A Different Beat: Writings by Women of the Beat Generation. Richard Peabody, ed. 1997; 235 pp. \$13.99. Serpent's Tail. **Women of the Beat Generation: The Writers, Activists, and Muses at the Heart of a Revolution.** Brenda Knight, ed. 1996; 384 pp. \$19.95 Conari Press. **Collected Poems: 1947-1980.** Allen Ginsberg. Reprint edition, 1998; 837 pp. \$23. HarperCollins. **Fast Speaking Woman: Chants and Essays.** Anne Waldman. Expanded Edition, 1996; 159 pp. \$10.95. City Lights Books, 261 Columbus Avenue, San Francisco, CA 94133, 415/362-8193, www.citylights.com. **Naked Lunch.** William S. Burroughs. Reissue edition, 1992; 255 pp. \$9.95. Grove Press. **The Beat Book.** Anne Waldman, ed. 1996; 300 pp. \$24. Shambhala. **The Jack Kerouac School of Disembodied Poetics.** Naropa Institute, Admissions Office, 2130 Arapahoe Avenue. Boulder, CO 80302, 303/546-3583, www.naropa.edu.

THE BEAUTY OF DISCONNECTION

by MALCOLM MARGOLIN

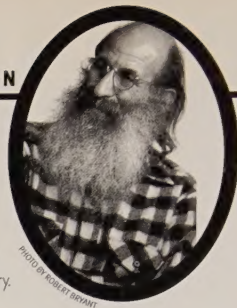

Malcolm is publisher of Heyday Books, the finest regional book company known to Whole Earth. It is amazing how many facets of California history and nature Malcolm has nurtured to press—the best book on biodiversity, the best Native American newsletter, the best books of the Great Valley and on Berkeley writers, etc., etc. His own work, especially *Ohlone Way* and *Earth Manual* (see p. 29) have been instant bioregional classics—calm, erudite, and straightforward. Malcolm's two now-grown children kindle my faith: imagination and fun will not perish in the next century.

I recently attended an environmental conference with the slogan prominent on its promotional literature and program brochure, "It's all connected." It made me sad to hear that. I had a twinge of the same kind of sadness I felt when I first read and understood the implications of John Muir's wonderful insight: "When we try to pick out anything by itself, we find it hitched to everything else in the Universe." The same kind of sadness I feel when I read something by Joseph Campbell or some other Jungian that shows that underlying the apparent diversity of religious belief and practice are almost identical images and concerns. The same kind of sadness and uneasiness as when someone tells me that I'm a member of the Global Village. It's all connected, is it? Ouch! How do I disconnect?

It's not that I don't recognize the power and beauty, even the truth, of this manner of thinking. Muir's astonishing statement—so clear, irreducible, and forceful—is surely one of the great energizers of the modern ecology movement, which is perhaps the one thing that will save us in the end. It is a statement both profoundly religious and profoundly practical. For me it is also profoundly troubling. Along with the mystical wonderment and sense of ecological responsibility that comes with the recognition of connectedness, more disturbing images come to mind. When applied to economics, connectedness seems to take the form of chain stores, multinational corporations, and international trade treaties which wipe out local enterprise and indigenous culture. When I think of it in the realm of religion, I envision smug missionaries who have done such a good job of convincing native people everywhere that their World-Maker is the same as God, and by this shoddy sleight of hand have been steadily impoverishing the world of the great fecundity and complex localism of belief systems that capture truths outside the Western canon. And I wonder—if everything's connected, does that mean that everything can be manipulated and controlled centrally by those who know how to pull strings at strategic places?

For the last twenty-five years my writing and publishing—never all that connected to mainstream concerns—have been heavily involved with California Indian culture and history. At one time California had over 500 politically independent tribal entities who spoke about one hundred distinct and mutually incomprehensible languages and who lived in a wide variety of ecological settings. While these groups may have been connected by marriage, trade, and other cultural ties, each was also proudly independent and unique, linked to a particular territory for most of its food, building material, and divine energy. Others, I suppose, might look over this bewildering array of humanity and discern connectedness—similarities of economy, belief, social structure, etc. But I keep stumbling, everywhere I turn, upon wonderful differences.

Take, for example, the Yurok language of the lower Klamath River in northwestern California. Once spoken by perhaps 2,000 people—quite enough for a complex language such as this—its future as a living language now rests in the hands of slightly more than a dozen fluent speakers, all quite elderly. There are many marvelous qualities to this language, but let me describe just one: its manner of counting. There are fifteen different ways of counting in Yurok,

depending upon what is being counted. Two humans, for example, are described by the numeral *ni'iyet*. Two houses, however, are *a'a'li*. Different words are likewise used for two boats; two worms, snakes, ropes, or other long, skinny things; two trees; two plants other than trees; two tools; two rocks, coins, or other round objects; etc. I find myself filled with great joy when I encounter something like this, when I catch a glimmering of the way in which a language can capture and encode a significant—and to me—revelatory truth. They are right, of course. It is quite clear that the seven-ness of seven human beings is qualitatively different



from the seven-ness of seven trees, both of which are qualitatively different from the seven-ness of seven birds, and so on. How precise this language is, to pay tribute to distinctness and to force those who speak that language to acknowledge the incomparability of different things. Our own system of counting, one-size-fits-all, has

produced enormous benefits. It has allowed for a system of mathematics by which we can explore everything from the subatomic to the intergalactic. Our math-based science has given us the tools for understanding so much of the universe, and for controlling it, too. Yet I can't help but feel that among all the gains, we have lost something, something essential and truthful. We have lost a manner of thinking that allows us to see the world as something composed of unique, distinct, incomparable entities and small systems of great variety, great individuality, with rugged strengths and inviolable character.

If indeed it is all connected, I guess that eventually we'll find a single political system, economic system, religious system, and language that will cover it all. I hope these systems are good ones, kind to people and other inhabitants of the world, capacious enough to allow for at least some variety and complexity. Perhaps, along with everyone else, I too am working toward it. I have no doubt that in the years to come I'll attend more conferences, where I'll give out my phone number and address so as to increase my connectedness to others, thereby contributing—whether I want to or not—to the systems that are horrifically linking us all. I don't think I'm strong enough to withstand the epidemic of connectedness entirely. But for as long as possible, I'll honor and draw strength, wisdom, and insight from people and from ways of thinking that celebrate not the connectedness, but rather the uniqueness of the things around us. I'll continue to write along those lines, publish along those lines, and I hope, perhaps, read the writings of others who understand that other and beautiful world, that other and beautiful kind of truth. ∞

NAVAJO NIGHTWAY CHANT

Happily may fair yellow corn, fair blue corn, fair corn of all kinds, plants of kinds, goods of all kinds, jewels of all kinds, come with you to the ends of the earth....

Happily the old men will regard you
Happily the old women will regard you
The young men & the young women will regard you
The children will regard you

Happily as they scatter in different directions they will regard you
Happily as they approach their homes they will regard you

May their roads home be on the trail of peace
Happily may they all return

In beauty I walk
With beauty before me I walk
With beauty behind me I walk
With beauty above me I walk
With beauty below & about me I walk
It is finished in beauty
It is finished in beauty



Sandpainting based on the legend of the Scavenger in the Eagle's Nest. From Navajo Medicine Man Sandpaintings

The Ohlone Way. Malcolm Margolin. 1981; 182 pp. \$12.95. Heyday Books, PO Box 9145, Berkeley, CA 94709, 510/549-3564.

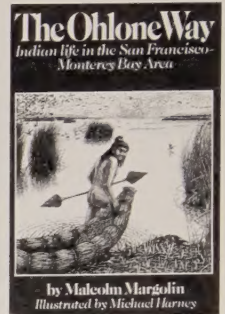

The Unknown Craftsman. Soetsu Yanagi. Revised edition, 1990; 230 pp. \$32. Kodansha International. **Navajo Medicine Man: Sandpaintings.** Gladys A. Reichard. 1997; 83 pp. \$12.95. Dover. **Tibetan Thangka Painting: Methods and Materials.** David Jackson and Janice Jackson. 1998; 202 pp. \$40 (\$48 postpaid). Snow Lion, PO Box 6483, Ithaca, NY 14851, 607-273-8519, www.snowlionpub.com/.

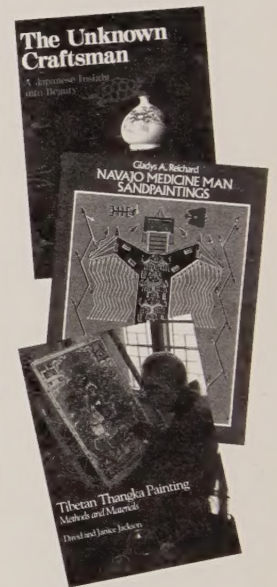

BACKMATTER

WHERE WE'RE AT

by ALEX GAULT, PUBLISHER



Whole Earth earns about eighty-five percent of its budget from subscriptions, newsstand sales, advertising, and peripheral sources. In that, we're the envy of most nonprofit magazines. Still, in order to keep publishing, we depend on gifts and grants for the remaining fifteen percent, about \$120,000 annually. In a crowded newsstand market, with shrinking numbers of independent booksellers and other outlets, most general interest magazines struggle. Many with much larger circulations and much more advertising than ours don't pay their own way. If you subscribe to any of a long list of magazines—the *Nation*, *Mother Jones*, *Tricycle*, even *Consumer Reports*—you've recently received appeals for help.

We still need your support. At the same time, we are pursuing other sources. We will continue to seek underwriting for special theme issues, and to explore books and other formats for our material. Wonderful musicians have offered to perform at benefit concerts. The Marin Community Foundation has set up the Point Foundation Fund, under their auspices, to receive gifts which can serve as an endowment for Whole Earth's future. Many Marin notables showed up to help us

celebrate this fund, among them Peter Coyote, Stewart Brand, Mayumi Oda, Danica Remy, Sim van der Ryn, and Ty Cashman. Marin Community Foundation also has great enthusiasm for a private library to give the public access to our thousands of books and provide a reading room for all the newsletters and bioregional magazines we receive. Our fantasy includes a "tool library" with a rotating exhibit of appropriate technologies.

We depend on our friends and readers each year. If you've given before, thank you again for your support. If you haven't given, please consider a tax-deductible gift now. Another wonderful way to support Whole Earth is to give subscriptions to your local school, college, or library. Please ask every newsstand you stop at for Whole Earth, and request them to carry it. If you have questions about Whole Earth's use of donated funds, or other questions about the business, don't hesitate to contact me at 415/256-2800, ext. 225 or by email: alex@wholeearthmag.com.∞



Barbara and Mishka, volunteers at the Whole Earth booth at Bioneers Conference with our business manager, Anna.

CONTRIBUTORS' GUIDELINES

Send submissions to:
Whole Earth, 1408 Mission Avenue,
San Rafael, CA 94901;
fax 415/256-2808;
email: editorial@wholeearthmag.com.

For a copy of our guidelines, write or email to the addresses above or see our website, www.wholeearthmag.com

THANKS

Whole Earth is grateful to these people who have provided editorial assistance; illustration and permissions procurement; and business, fundraising, and circulation help on this issue.

- Kenny Ausubel (Bioneers)
- Judy (Shapiro) Baxter
- Kate Barrett (Real Goods)
- Bela Banathy (International Society for Systems Science)
- Jan Conroy (Yale Law School)
- Carl Dern (sculptor)
- Daphne Derven (American Center for Wine, Food, and the Arts)
- Christiann Gibeau (Global Business Network)
- Sidney Goldfarb (playwright)
- Jeff Gunderson (San Francisco Art Institute)
- Joshua Jacobs (Mandala Designs)
- Leonard Jacobs (Mandala Designs)
- Kevin Kelley (photographer)
- Marvin Lipofsky (glass blower)
- Sally McCracken (literary agent)
- Peter Menzel (photographer)
- Tony Mish (Lick Observatory)
- Karen Peterson (Margaret Mead Centennial)
- Elaine Petrocelli (Book Passage)
- Rolf Skar (Northwest Earth Institute)
- Remington Stone (Lick Observatory)
- William Stout (Stout Publishers)
- John Strohmeier (Berkeley Hills Books)
- Lee Swenson (Institute for Culture and Society)



Middle Oval: Baldwin, Alex, Mike, Anna, and Lyssa. Left Ovals: Maren (intern), Danica (Board President), Peter (with desert tortoise). Right Ovals: Robin O'Donnel (keyboard wizard), Monika Olson (designer), Stephanie Johnston (designer).

SUPPORTERS

Whole Earth relies on the generous support of its readers and foundations to make ends meet. We gratefully thank all those readers and friends who have given, at any level. (Phone Alex, 415/256-2800, ext. 225, to find out the "perks" offered at each giving level.) Particularly, the following people deserve special thanks:

MANIACALS (\$1,000+)

- Jaime Lubin Acosta
- Cash Adams
- Petra-Leilani Akwai
- Jules Alciatore
- Denise & Norman Alm
- Kathy Archibald
- August
- Michael Lee Bailey
- Bambu Flyingwater
- John Perry Barlow
- Leona & Bruce Baumgart
- Bernard Bildman
- Steve Blake
- Bernard Bonno
- Alex Bornstein
- Allen Boorstein
- Donna Boyd & Gene Combs
- Mark & Amanda Brady
- Jim & Anne Bredouw
- David & Sandra Burns
- Stephen & Julie Briggs
- Andre Carothers
- Kelley Celmner
- Harvey Chang
- Polly Cherner

- Continuous Wave
- Joe S. Coulombe
- Alasdair Coyne
- Carol Cricow
- Harriet Crosby
- Jerry Crutcher
- Bob Culley
- Henry Dakin
- W. Dale, Jr.
- Tim Dalmau
- Lynn Dondero, M.D.
- Robert Dunn
- Editora Espaco E Tempo Ltda.
- Everything is Important,
- Nothing Matters
- Hilary Fried
- Jonathan Frieman
- Alex Funk
- Toni Garrett
- David Gottlieb
- Ed Grover
- Diana Hadley
- Eric Haines
- Haines Borough Public Library
- Hampshire College Frog
- Daniel Hancock
- Stephen F. Haust

- Johanna Hill
- David & Kay Hines
- Stephen Hodgkin
- Allan Hogle
- Harold Hunter
- John Hunting
- R. W. Hurd
- Michael O. Johnson
- David Johnston
- Elizabeth Jones
- Mitch Kapor
- Kinswoman
- David Kittrell
- Kevin J. Kiwak
- Christopher Le Bret
- Lawrence Lewis
- Kevin Lindsey
- Viki List
- John Litt, in memorium
- Steve Littlewood
- James E. Lovelock
- Lucky Loner of the Lurker Legions
- Antione Maamari
- Randy Mack
- Joshua Mailman
- Douglas Martin

- Bill Mayben
- Luther & Gloria McLeod
- Pierce McNally
- Arthur Milholland, M.D.
- Elise Miller
- Russ Molari
- James Moores
- Joseph Murphy, Jr.
- Michael Nathan
- W. K. Nelson
- Anne Norcia
- Joshua Nottowitz
- Ray Olszewski
- Gary Owens
- Norman Pease
- Tom Peters
- Surse Pierpoint
- Plant Just One Tree
- Julian Price
- Ron Pruitt
- J. H. Reynolds
- Pierre A. Rioux
- Marcelo Rocha
- Maria Rodale
- Hans Nick Roericht
- John Romkey
- Jonathan Rose

- William Rosenzweig
- Bret Russell
- Jim Sanders
- The Schumacher Family
- Jim Sells
- Norman & Joanna Sher
- Virginia L. Smith
- Lydia G. Storey
- Marion Sweeney
- Mack Taylor
- Jack Tempchin
- Katherine Tremaine
- R. Burr Tweedy
- Marc Valens
- Gary Waldron
- Bob Wallace
- S. Ashley Webb
- Betsy Weedon
- Samuel Wigley
- David Williams
- Greg & Pat Williams
- Linda Wilson
- Gertrude & Theodore
- Winsberg
- J. Kirk Wood
- Michael Woo

- ### ANGELIC (\$5,000+)
- Jenifer Altman Foundation
 - Jeffrey Bronfman
 - Kimo Campbell
 - Felix Dennis
 - Kingsley H. Murphy, Jr.
 - Institute for Noetic Sciences
 - The Philanthropic Collaborative
 - Richard Rockefeller

- ### PERPETUAL (\$10,000+)
- Grant Abert
 - Allswell
 - Marlon Brando
 - Tyrone Cashman
 - Center for Ecocitery
 - Compton Foundation
 - Foundation for Ecology and Development
 - Flow Fund
 - Marin Community Foundation
 - Preservation Fund
 - Sacharuna Foundation

BACK COVER: GLASS PLATE PHOTO OF SOLAR ECLIPSE ON JANUARY 22, 1898 IN CENTRAL INDIA. PRINTED FROM THE LICK OBSERVATORY ARCHIVES BY LINDA CONNOR. © UNIVERSITY OF CALIFORNIA, SANTA CRUZ. CREDIT: LINDA CONNOR/LICK OBSERVATORY.

WHOLE EARTH BACK ISSUES

For 30 years, Whole Earth has presented unorthodox ideas and tools which have become mainstays of American culture.

Gaia, cyberspace, community networking, renewable energy, and biodiversity: explore their origins in the pages of Whole Earth, Whole Earth Review, and CoEvolution Quarterly.

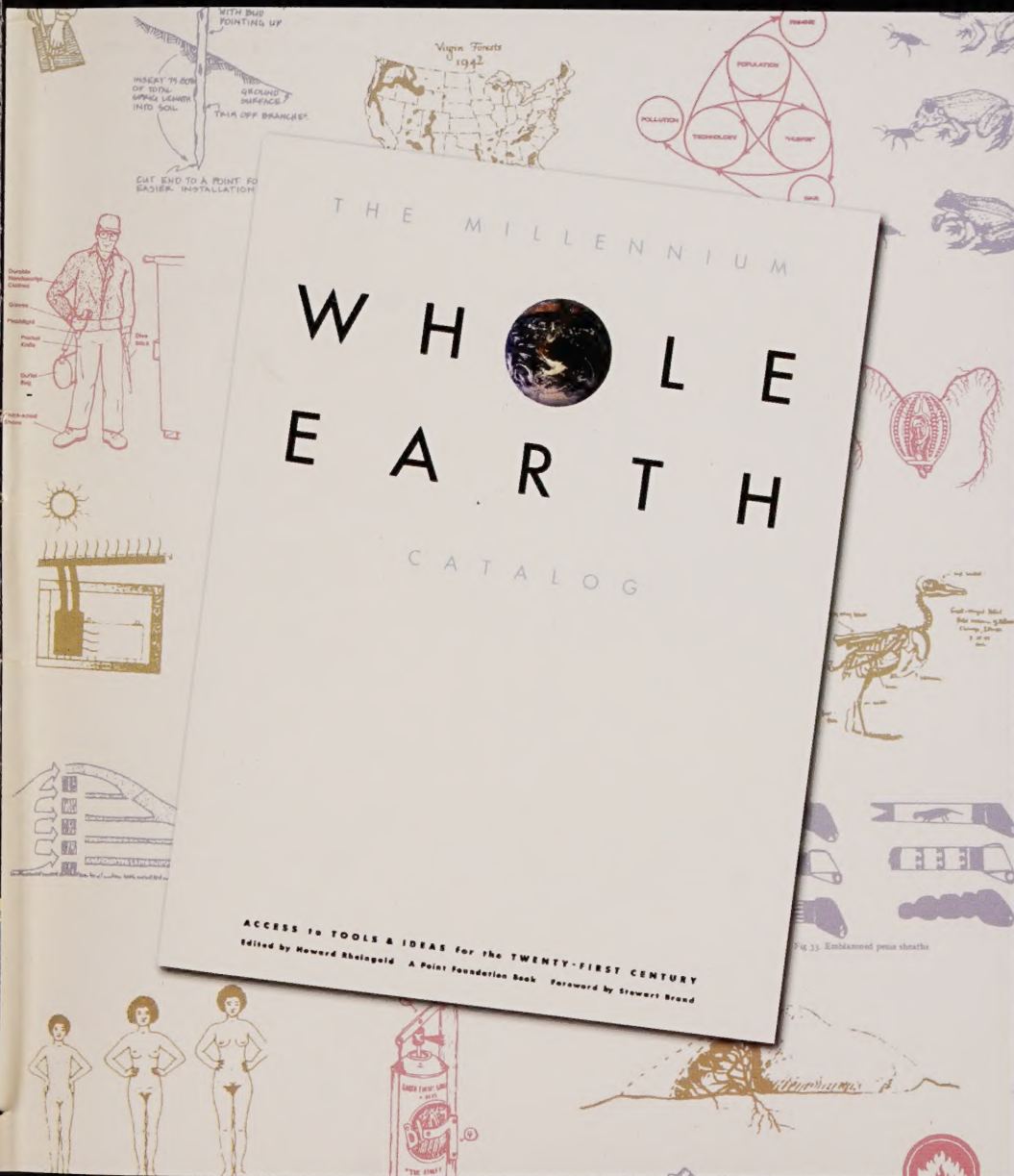
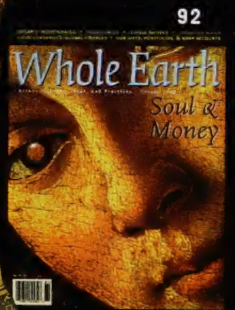
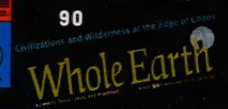
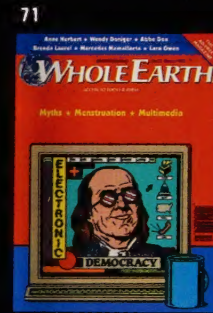
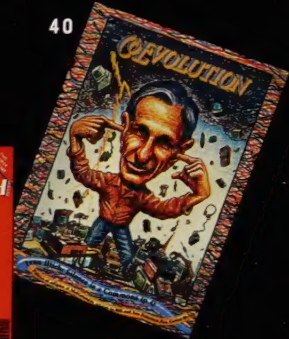

Millennium Whole Earth Catalog
\$30. Canada: \$35. International: \$45.

\$12 ISSUES:

15, 16, 17, 18, 19, 20, 21, 22, 23, 24, 29, 31, 33, 35, 39, 41, 42, 44, 46, 47, 62, 66, 70, 71, 73, 74, 75, 76, 78, 79, 80, 81, 82, 83, 84, 86, 87, 88, 89, 90, 91, 92, 93, 94

\$35 ENDANGERED ISSUES:

2, 5, 10, 11, 12, 13, 14, 25, 26, 28, 30, 32, 34, 36, 37, 38, 40, 43, 45, 48, 49, 50, 53, 54, 56, 58, 59, 63, 65, 67, 72, 77

POSTAGE:

U.S.: postage paid.
Canada: \$3 for the first issue;
\$1 for each additional.
International: \$5 for the first issue,
\$2 for each additional.

TO ORDER:

Call: 888/732-6739
Mail a check to: Whole Earth, P.O. Box 3000,
Denville, NJ 07834

Or visit our website: www.wholeearthmag.com

We can't put it together.

It is together.

